

Smart Cart  
page 98

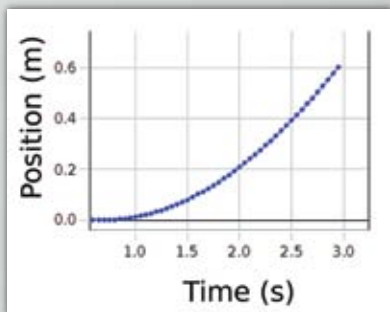

Smart Fan  
Accessory  
page 103



**NEW!**

Smart Fan Accessory for PASCO's  
Wireless Smart Cart. A great  
pair for teaching dynamics page 103



# What's new...

## Equipment

### Hall Effect Apparatus (n-doped Germanium)

SE-7260

See page 290

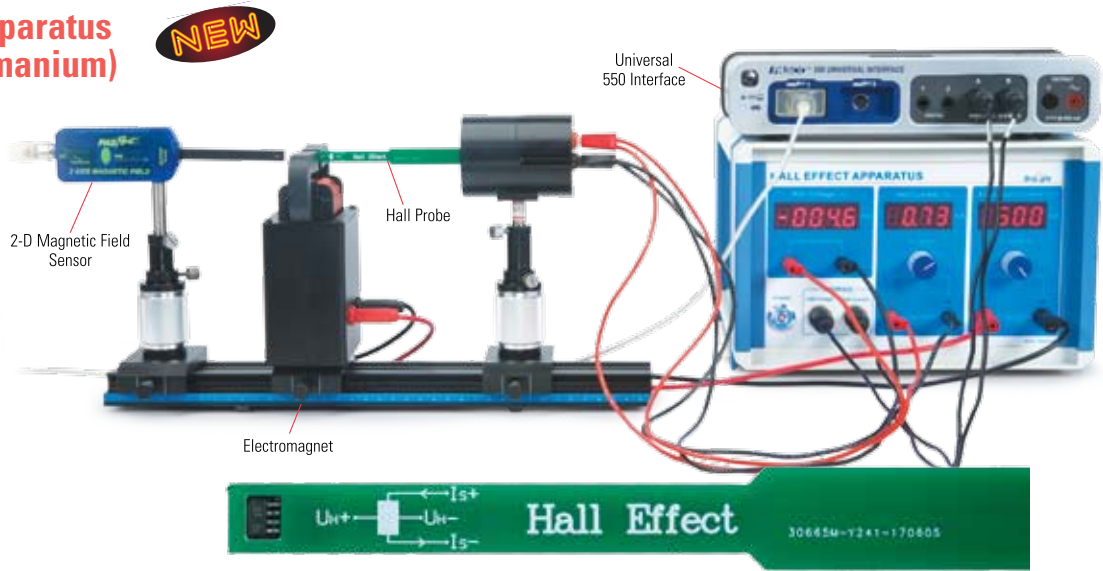

## New Design

### Mini Launcher

ME-6825B See page 125



### Time-of-Flight Accessory

ME-6810A See page 126



## Curriculum

### Essential Physics 3rd Edition

EP-6323

See page 84



# Table of Contents

## FLIR C3 Thermal Imaging Camera

SE-7128A

**Now with WiFi**

See page 281



## Wireless Colorimeter and Turbidity

PS-3215 See page 60



## Wireless Weather Sensor with GPS

PS-3209 See page 72



## Wireless Exercise Heart Rate Sensor

PS-3207 See page 66



## Wireless Hand-Grip Heart Rate Sensor

PS-3206 See page 67



## Modular Circuits

Basic Modular Circuit Kit EM-3535

Essential Physics Kit EM-3536

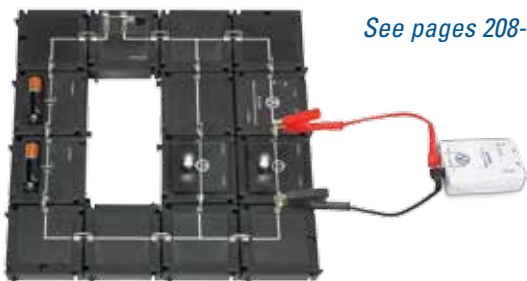

See pages 208-209

	Page
New Products	2-6
Legacy Products	7
Sensors and Interfaces	8-15
Wireless Sensors	16
PASCO Capstone™ Software	18-20
SPARKvue®, Spectrometry, & MatchGraph Software	21
Sensors	22-75
Curriculum & Bundles	76-91
Mechanics	92-189
Carts & Tracks	92-121
Freefall & Projectile Launchers	122-131
Statics & Pulleys	132-137
Human Applications	138-139
Structures System	140-147
Material Testing	148-154
Springs & Oscillations	155-157
Rotation	158-170
Fluids & Density	171-175
Lab Supplies	176-189
Thermodynamics	190-203
Electrostatics	204-207
Circuits	208-218
Energy & Generators	219-222
Magnetism	223-230
Power Supplies & Instrumentation	231-241
Waves & Sound	242-253
Optics Systems	254-271
Spectrometry & Interferometry	272-284
Cameras & Microscopes	285
Fundamental Constants	286-295
Atomic & Nuclear	296-301
Experiments	302-357
Professional Development	358-359
Index	360-381
Order Information	382-383
Teacher Support	384

# Essential Physics Curriculum **NEW** For complete details, see pages 84-87.

**This complete physics solution includes Textbook, e-Book, Digital Teacher Edition, and Equipment!**

Essential Physics 3rd Edition is a comprehensive, full-color textbook paired with PASCO equipment and the only e-Book for physics on the market. The program includes over 100 interactive tools that increase student engagement and understanding. Essential Physics is focused on practical applications that connect students to the physics of nature as well as technology.

## About the program:

- ▶ Rigorous yet accessible design
- ▶ Interactive simulations and equations
- ▶ Lessons follow the 5E design
- ▶ Strong mathematics scaffolding
- ▶ Formative and summative assessment tools
- ▶ Differentiation for advanced, below-level, and ELL students
- ▶ Works seamlessly with your LMS and Google Classroom
- ▶ Includes 24/7 online/offline access. No Internet required!

**Textbook**

**e-Book**

**Digital Teacher Edition**

**Equipment**

**Assessment**

**What is friction?**

Friction is a "catch-all" term that collectively refers to all forces caused by motion which act to reduce motion. Friction transforms energy of motion into thermal energy or the wearing away of moving surfaces.

**Calculating static friction**

A 10 N wood board is on a table. How much force does it take to make the board slide if  $\mu_s = 0.2$ ?

$$F_f = \mu_s F_N$$

$$= (0.2)(10 \text{ N}) = 2 \text{ N}$$

2 N is the minimum force needed to make the board start moving.

2 N is also the maximum force of static friction. The actual force of static friction is equal and opposite to any applied force up to the maximum.

**PASCO**

PASCO is also offering the new Essential Chemistry program. Go to [pasco.com/essentialchemistry](http://pasco.com/essentialchemistry) for details.

**Essential Physics is multiplatform: iOS, Android™, Chrome™, Windows®, PC, and Mac®!**

## Smart Fan Accessory

**NEW**

ME-1242

- ▶ Provides a Constant Force
- ▶ Hands-off Operation
- ▶ Sense and Control
- ▶ Manual Mode for Non-Smart Carts

The Smart Fan Accessory becomes smart when plugged into a Smart Cart.

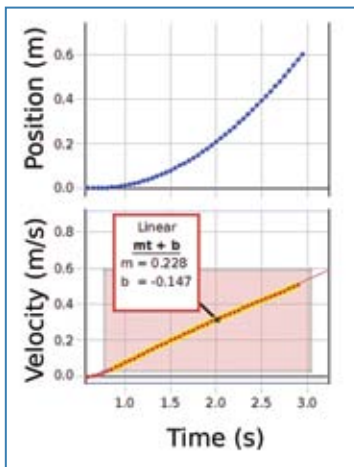

### What makes this fan so smart?

If you use this fan on a regular cart, you can turn it on and select one of three speeds by pushing the button on the side. But plugging it into a Smart Cart gives this Smart Fan Accessory added capabilities:

*For complete details, see page 103.*

## Hall Effect Apparatus (n-doped Germanium)

**NEW**

SE-7260

- ▶ Variable magnetic field and current
- ▶ Open design makes current direction clear
- ▶ Works with 550 or 850 Universal Interface

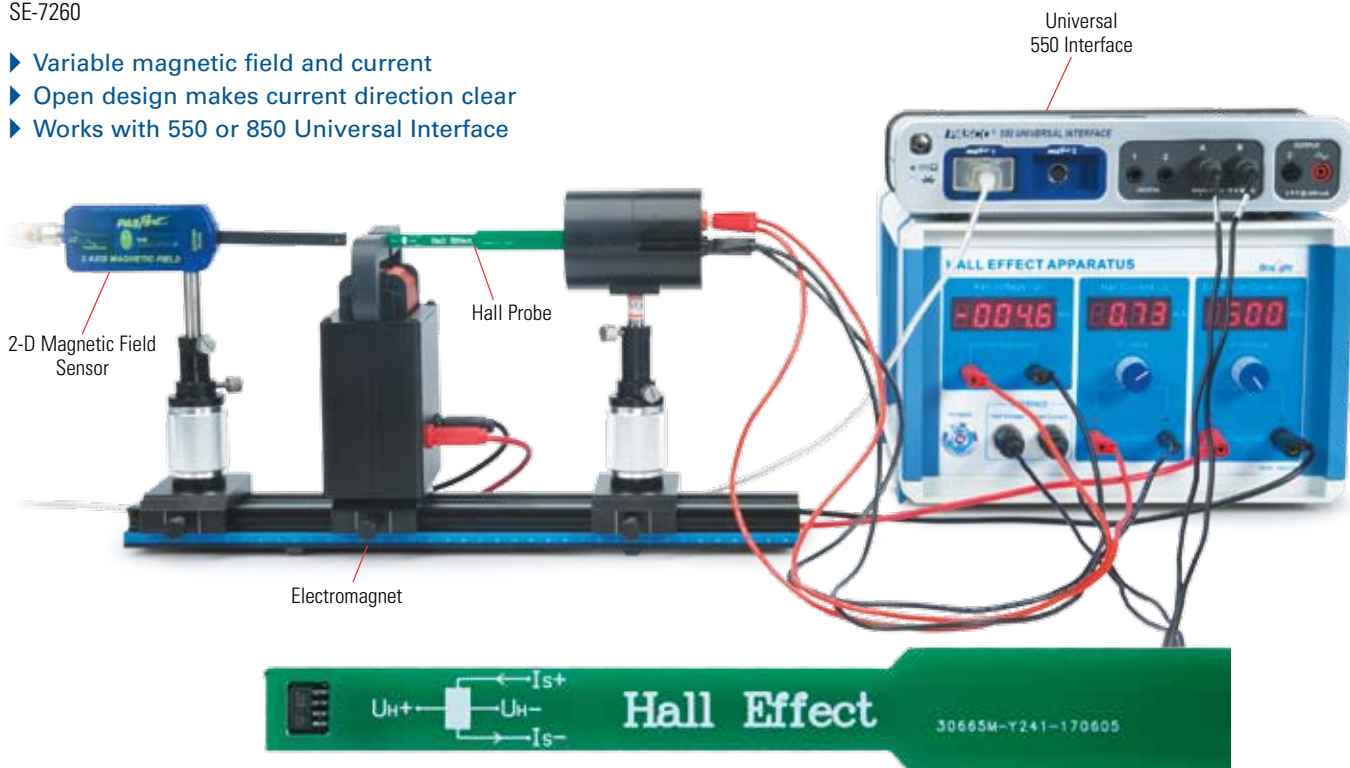

*For complete details, see page 290.*

# New Features of PASCO Capstone Software

- ▶ Bar Meter
- ▶ New Video Analysis display makes it easier to get started with video analysis
- ▶ New Image display options allow image capture and image analysis
- ▶ Titration tool enabled when running in French language
- ▶ New tool for the Smart Fan Accessory
- ▶ Synchronize the recording of multiple wireless sensors
- ▶ Open SPARKvue files in Capstone

## Bar Meter

A bar meter has one or more bars that go up and down as the measurement value changes. In this example, eight temperature sensors are distributed along a metal bar and one end is immersed in boiling water and the other is immersed in ice water. The eight bar meters show the temperatures along the metal bar as it reaches a dynamic equilibrium.

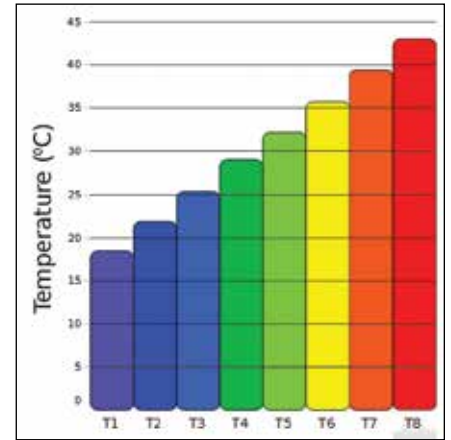
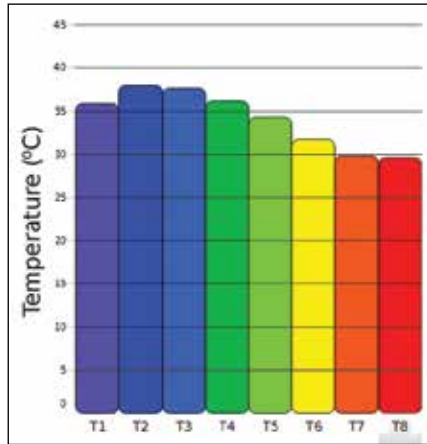

## Annotate and Measure Imported or Captured Images

Import or capture a still image and use image analysis tools to measure distances and angles. Annotate a picture of the apparatus.

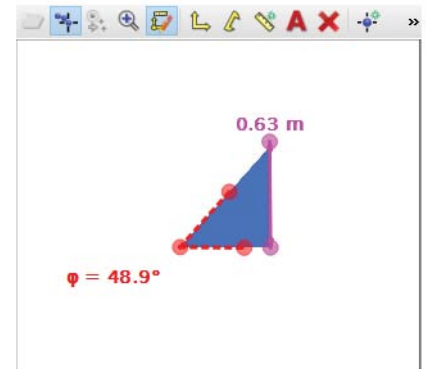

Create a data set by clicking on the image (such as a hanging rope) to analyze the shape of the rope using a curve fit.

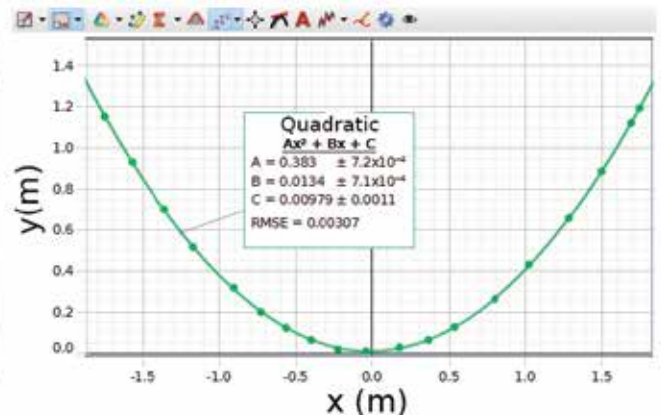
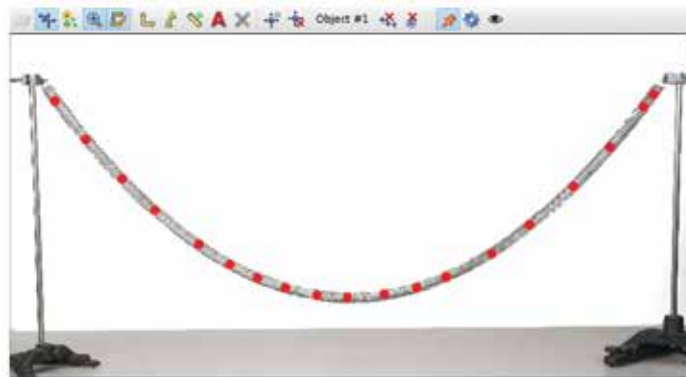

## Tangent Method for Analyzing Titrations (in French Language Mode)

Designed for the French curriculum, a new Tangent tool appears in the graph if Capstone's language is set to French. This tool finds the equivalence point for titrations using the Tangent Method.

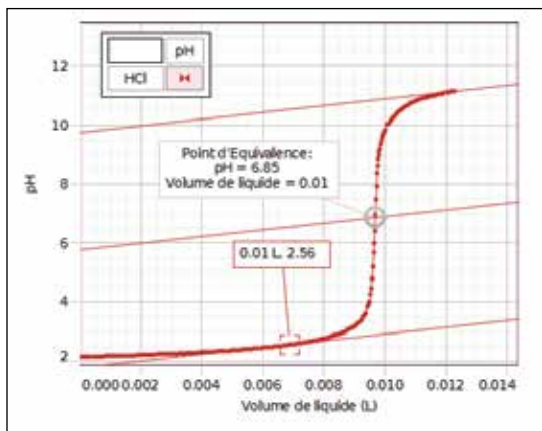

## Smart Fan Control

When the new Smart Fan Accessory is plugged into a Smart Cart, you can control the Smart Fan directly from Capstone.

- Use the slider to set the thrust.
- Set the fan to turn on and off based on a measurement (such as Smart Cart Position) or time.
- Hands off: Start the fan remotely in the software.
- Use a calculation to define the thrust:  $\text{Thrust} = 10 * [\text{Force}]$  will make the thrust proportional to the force exerted on a force sensor.

## Sync Multiple Wireless Sensors

With PASCO's new syncing technology, wireless sensors are automatically synced as soon as more than one is plugged in. If you desire to sync them more closely just before recording, you can click on the new sync button on the Sampling Control bar.

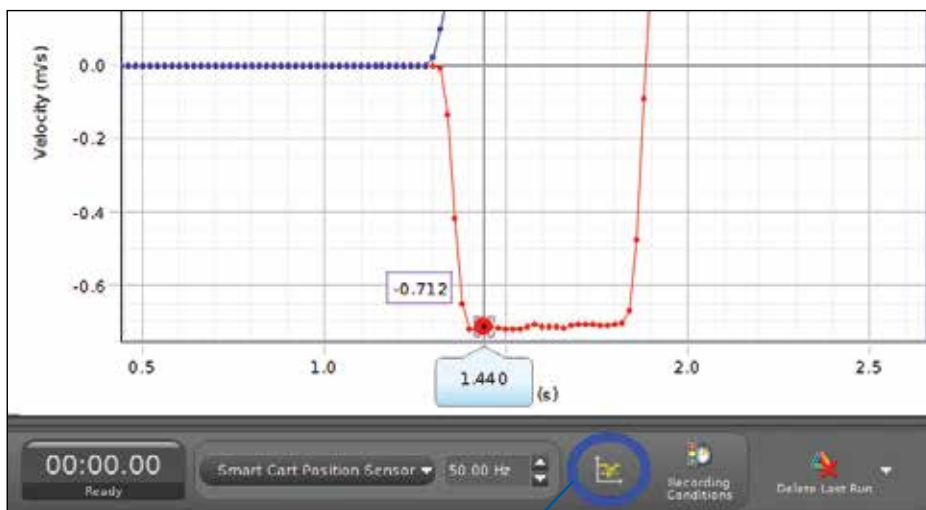

Wireless Sensor  
Sync Button

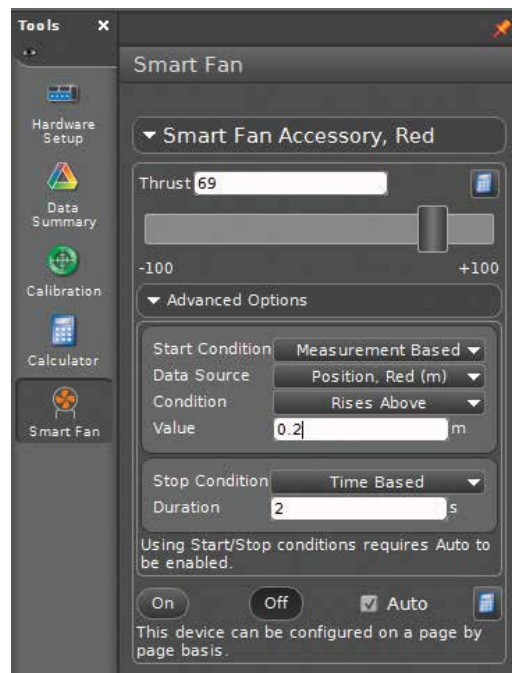

See more Capstone  
information on  
pages 18-20.

## Open SPARKvue Files in PASCO Capstone

Collect data using a mobile device running SPARKvue Software and then open the SPARKvue file in Capstone for more extensive analysis.



# New Products



## Wireless Colorimeter and Turbidity

PS-3215 See page 60



## Wireless Weather Sensor with GPS

PS-3209 See page 72



## Wireless Exercise Heart Rate Sensor

PS-3207 See page 66



## Wireless Hand-Grip Heart Rate Sensor

PS-3206 See page 67



## Heater-Stirrer

PS-3401 See page 58



## Mini Launcher

ME-6825B See page 125



*New bracket features*



## Time-of-Flight Accessory

ME-6810A See page 126



*New Design*



# 2018 Legacy Products

After many years of production, these products are now in legacy status. This means that they will be available to purchase through the end of 2018 unless an unforeseen problem arises in production. These products do not appear in this catalog but are still available on [www.pasco.com](http://www.pasco.com). They will be obsolete in 2019. Get them while you can!

Part Number	Description	Recommended Replacement
CI-6746	Economy Force Sensor	Force Sensor, CI-6537
EM-8090	Hand Crank Generator	Mini Generator, SE-8645
EM-8677	Series/Parallel Circuit	Basic Modular Circuits, EM-3535
EP-6474	Ergotrack, Essential Physics	Essential Physics Kits moving to PASCO track
PS-2102	PASPORT pH Sensor	Wireless pH, PS-3204
PS-2104	PASPORT Force Sensor	PS-2189 High Resolution Force Sensor or PS-3202 Wireless Force Acceleration Sensor
PS-2110	PASPORT Carbon Dioxide Gas Sensor	Wireless CO <sub>2</sub> , PS-3208
PS-2113A	PASPORT Barometer/Low Pressure Sensor	Wireless Pressure, PS-3203
PS-2116A	PASPORT Conductivity Sensor	Wireless Conductivity, PS-3210
PS-2121	PASPORT Colorimeter	Wireless Colorimeter and Turbidity, PS-3215
PS-2122	PASPORT Turbidity Sensor	Wireless Colorimeter and Turbidity, PS-3215
PS-2124A	PASPORT Humidity/Temperature/Dew Point Sensor	Wireless Weather with GPS, PS-3209
PS-2129A	PASPORT Exercise Heart Rate Sensor	Wireless Exercise Heart Rate, PS-3207
PS-2147	PASPORT High Precision pH/Temp Sensor with ORP/ISE Amplifier	Wireless pH, PS-3204
PS-2154A	PASPORT 6-in-1 Weather Sensor	Wireless Weather with GPS, PS-3209
PS-2170	PASPORT Chemistry Sensor	Wireless pH, PS-3204; Wireless Temperature, PS-3201; Wireless Pressure, PS-3203; Wireless Voltage, PS-3211
PS-2172	PASPORT Advanced Chemistry Sensor	Wireless pH, PS-3204; Wireless Temperature, PS-3201; Wireless Pressure, PS-3203; Wireless Conductivity, PS-3210
PS-2174	PASPORT Weather/Anemometer Sensor	Wireless Weather with GPS, PS-3209
PS-2175	PASPORT GPS Position Sensor	Wireless Weather with GPS, PS-3209
PS-2186	PASPORT Hand Grip Heart Rate Sensor	Wireless Hand-Grip Heart Rate, PS-3206
PS-2230	PASPORT Advanced Water Quality Sensor	Optical Dissolved O <sub>2</sub> , PS-2196, + AirLink, PS-3200; Wireless Temperature PS-3201; Wireless Conductivity, PS-3210; Wireless pH, PS-3204
PS-2509	Replacement Cuvettes and Caps (Set of 6)	
PS-2512A	Replacement Transmitter and Belt - Exercise Heart Rate Sensor	Replaced by PS-3564 for Wireless Exercise Heart Rate
PS-2527	Rechargeable Battery, Xplorer GLX	Replacement item for GLX; PASCO will continue to stock for customer needs.
PS-2529	Xplorer GLX AC Power Adapter	Replacement item for GLX; PASCO will continue to stock for customer needs.
PS-2529-220	Xplorer GLX AC Power Adapter -220	Replacement item for GLX; PASCO will continue to stock for customer needs.
PS-2571	Conductivity Probe 10x	
PS-2572	Dissolved Oxygen Probe	
SE-7611	Renewable Energy Kit	
SE-7700	Magnetic Stirrer	Heater-Stirrer, PS-3401
SE-8830	Hot Plate	Heater-Stirrer, PS-3401
SE-9791	Resistor-Capacitor Circuit	Basic Modular Circuits, EM-3535, or Essential Physics Modular Circuits, EM-3536

# Measuring with Sensors

In Physics and Engineering, we measure everything in every way we can. Sometimes sensors can make possible measurements we could not get any other way.

PASCO offers a couple of different ways to go: interface-based sensors or wireless sensors. However, you can use a wireless sensor at the same time you are using sensors connected to an interface. Which way you choose depends on your platform and your purpose.

## Which platform do you use?

### 1. Mac® and/or Windows® Desktop Computers or Laptops

**Recommendation:**

- **PASCO Capstone Software** (see pages 18-20): This data collection and analysis software is the preferred choice of physics and engineering teachers.
- **550 or 850 Universal Interface:** Choose the 550 if you are teaching high school physics (unless you are one of those high school teachers who has to have the most powerful tools). Choose the 850 if you are teaching college physics or engineering.



850 Universal Interface  
UI-5000 (see pages 12-13)

or

550 Universal Interface  
UI-5001 (see page 14)



Wireless Force  
Acceleration  
PS-3202 (see page 29)



PASPORT  
High Resolution  
Force  
PS-2189 (see page 29)

### 2. Tablets (iPad® or Android™) and/or Chromebook™

**Recommendation:**

- **SPARKvue Software** (see page 21): Our tablet or Chromebook™ software is SPARKvue. PASCO Capstone is very powerful but it is only available for Mac® and Windows®.
- **Wireless Sensors and Wireless AirLink Interface:** Use wireless sensors because tablets may not have a USB port. Whenever a wireless sensor is not available, use the AirLink with a PASPORT sensor.



**SPARKvue**®



AirLink®  
PS-3200 (see pages 10, 16)



Wireless Force  
Acceleration  
PS-3202 (see page 29)

### 3. Want to Go Outside?

**Recommendation:**

- **PASCO Capstone** (see pages 18-20): Use this software with your desktop or laptop computer to prepare wireless sensors for datalogging and to download and analyze logged data.
- **Wireless Sensors:** Most of our wireless sensors have memory and can be disconnected from the computer to log data. When you return to the computer and connect wirelessly, you will be prompted to download your data.



Wireless Force  
Acceleration  
PS-3202 (see page 29)

# Are you new to sensor measurement or do you have sensors already?

## 1. New to Sensors?

- **PASCO Capstone Software** (see pages 18-21): Unless you are using tablets or Chromebook™, we recommend that you use Capstone for physics and engineering labs.
- **550 Universal Interface:** The 550 Interface is perfect for beginning data acquisition. It has multiple sensor ports to accommodate those experiments that require more than one sensor (as most experiments do). It also has a signal generator and powered output for electronics and speakers.
- **PASPORT Sensors** (see pages 24-75): Many of these sensors have multiple sensor elements in one sensor, such as the Absolute Pressure/Temperature Sensor (page 42).



550 Universal Interface  
UI-5001 (see page 14)

## 2. Have ScienceWorkshop Sensors?

- **PASCO Capstone Software** (see pages 18-21): Unless you are using tablets or Chromebook™, we recommend that you use Capstone for physics and engineering labs.
- **850 Universal Interface:** The 850 Interface is definitely the right interface for the ScienceWorkshop veteran. It has twice as many sensor ports as the 550 for those more demanding experiments. It also has three signal generators, a high-power output (15 V at 1 A) for speakers and heating elements, and two high frequency outputs (DC to 500 kHz) for electronics.
- **Use your existing ScienceWorkshop sensors** and add any PASPORT sensors you need: You may want to use the PASPORT 2-Axis Force Platform (page 31) or the Absolute Pressure/Temperature Sensor (page 42).



850 Universal Interface  
UI-5000  
(see pages 12-13)

## 3. Have PASPORT Sensors?

- **PASCO Capstone Software** (see pages 18-21): Unless you are using tablets or Chromebook™, we recommend that you use Capstone for physics and engineering labs.
- **550 or 850 Universal Interface:** Choose the 550 if you are teaching high school physics (unless you are one of those high school teachers who has to have the most powerful tools). Choose the 850 if you are teaching college physics or engineering.
- **Use your existing PASPORT sensors** and add the UI-5100 Voltage Sensor (page 52) for high speed sampling of circuits and the CI-6506B Sound Sensor (page 57) for detecting sound waves.



550 Universal Interface  
UI-5001  
(see page 14)

## 4. Have Non-PASCO Sensors?

- **PASCO Capstone Software** (see pages 18-21): Unless you are using tablets or Chromebook™, we recommend that you use Capstone for physics and engineering labs.
- **Wireless Sensors** (see pages 16-17): This is the least expensive way to get started because no interface is required. Try the Smart Cart: With four embedded sensors, it's a bargain!



Wireless Force Acceleration  
PS-3202 (see page 29)



Wireless Smart Cart  
ME-1240  
(see page 98)



# Interfaces

Use an interface to connect sensors to your computers or mobile devices running PASCO software.

**AirLink®**   
PS-3200



*The AirLink is the most cost-effective way to connect sensors.*

Connect one PASPORT sensor via Bluetooth® or through a USB connection. USB cable included.

**Order Information**

AirLink ..... PS-3200

**SPARKlink® Air**  
PS-2011



Connect two PASPORT sensors via Bluetooth® or through a USB connection. Also includes dedicated ports for the included temperature and voltage probes. USB cable included.

**Order Information**

SPARKlink Air ..... PS-2011

**550 Universal Interface**  
UI-5001



The 550 Universal Interface is fast, flexible, and powerful while staying affordable. The 550 has half the ports and many of the great features of our 850 Universal Interface in a smaller package with Bluetooth® and USB connectivity.

**Order Information**

550 Universal Interface ..... UI-5001

**850 Universal Interface**  
UI-5000



The 850 Universal Interface is the most powerful science education lab interface in the world, with the most ports, highest sampling rates, and the most powerful functionality and future expandability. It can also replace several pieces of lab instrumentation, which represents great value.

**Order Information**

850 Universal Interface ..... UI-5000

# Interface Comparison

Compare the features and capabilities and see which interface works best in your lab.



	AirLink PS-3200	SPARKlink Air PS-2011	550 Universal Interface UI-5001	850 Universal Interface UI-5000
PASPORT Ports	1	2	2	4
Analog Inputs	0	0	2 ( $\pm 10$ V, optional gain voltage 10x, 100x)	4 ( $\pm 20$ V, optional gain voltage 10x, 100x, 1000x)
Digital Inputs	0	0	2	4
Connects via USB	Yes	Yes	Yes	Yes
Connects via Bluetooth	Yes	Yes	Yes	No
Rechargeable battery for cordless operation	Yes	Yes	No (AC adapter only)	No (AC adapter only)
Works with PASCO Capstone Software	Yes	Yes	Yes	Yes
Works with SPARKvue Software	Yes	Yes	Yes	No
Accepts PASPORT Sensors	Yes	Yes	Yes	Yes
Accepts ScienceWorkshop Sensors	No*	No*	Yes	Yes
Maximum Sampling Rate	Sensor dependent <1000 Hz	Sensor dependent <1000 Hz	Up to 2 MHz on one channel	10 MHz on two channels simultaneously
Signal Generator	N/A	N/A	$\pm 8$ V, at 400 mA, DC to 100 kHz	#1 $\pm 15$ V at 1 A, DC to 100 kHz #2 & #3 $\pm 10$ V at 50 mA DC to 500 kHz, independent
Included Items	USB Cable	AC adapter, USB cable, fast response temperature probe, voltage probe	USB cable, Power supply	USB cable, Power Supply
Expansion Port	No	No	No	44-Pin port with voltage outputs, analog inputs, and digital I/O channels

\* The AirLink and SPARKlink Air can accept most ScienceWorkshop sensors with the proper adapter (see page 39) although they won't have the same high maximum sample rates. One exception is the Sound Sensor (CI-6504), which is not recommended for use with an adapter.

# The PASCO 850 Universal Interface:

## The Ultimate Sensor Interface for Physics and Engineering

Clear the clutter on your lab bench. The 850 Universal Interface combined with PASCO Capstone software can replace multiple expensive pieces of equipment.

*An incredible value!*

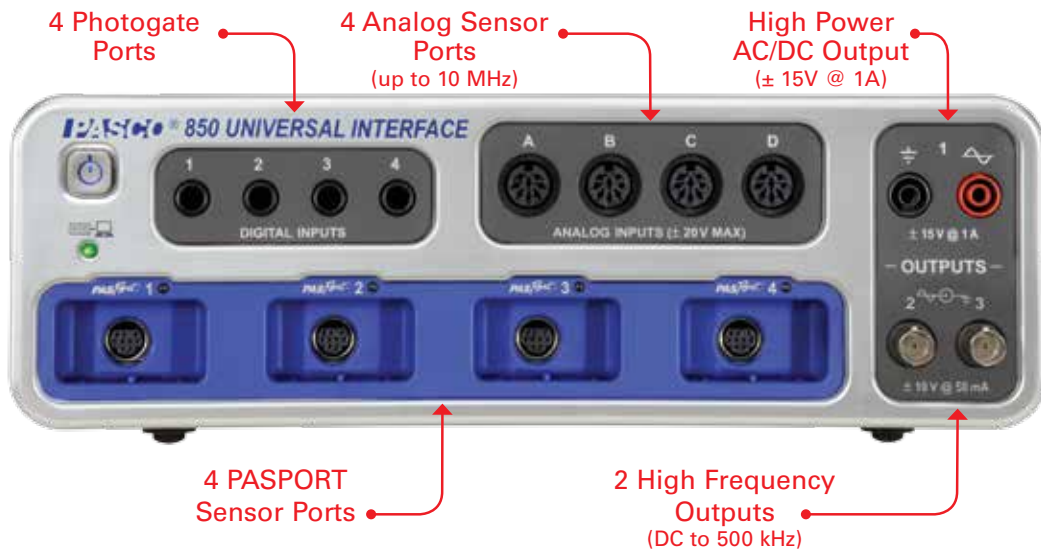

- ▶ **Study AC Circuits:** 10 MHz sample rate on two analog channels simultaneously; two independent high frequency outputs (50 mA at 10 V; DC to 500 kHz)
- ▶ **Power Speakers and String Vibrators:** High power function generator (1 A at 15 V; DC to 100 kHz)
- ▶ **Use Any Sensors You Have:** Compatible with ScienceWorkshop and PASPORT sensors; use at the same time
- ▶ **Explore Modulation:** External trigger input/output for synchronizing multiple 850s
- ▶ **Do 87 Core Physics Experiments:** Check out the Comprehensive 850 Physics Lab Manual (UI-5813) (see page 78). Download online at [pasco.com/comprehensivephysics](http://pasco.com/comprehensivephysics)
- ▶ **See detailed specifications:** [www.pasco.com/850](http://www.pasco.com/850)

Order Information	
850 Universal Interface.....	UI-5000
<i>Requires:</i>	
PASCO Capstone Software.....	p. 18
<i>Recommended:</i>	
BNC Function Generator Output Cable.....	p. 13

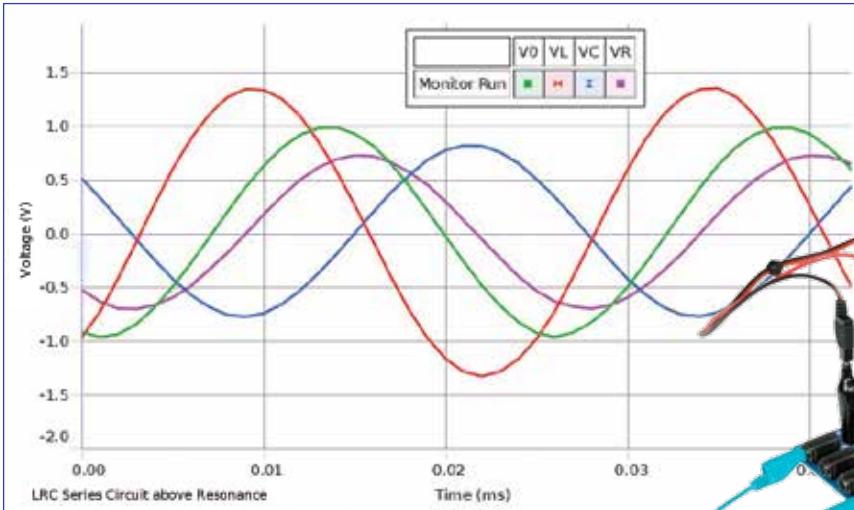

Four Channel Oscilloscope in PASCO Capstone

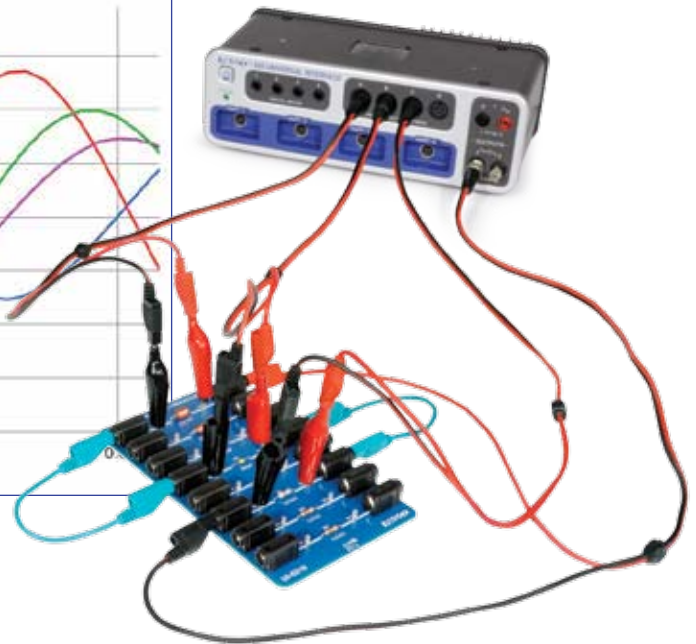

**Dual Independent High Frequency Function Generators**

Independent control of frequency, waveform, and amplitude. The voltages across the source, inductor, capacitor, and resistor are displayed in the oscilloscope.

**BNC Function Generator Output Cable**

UI-5119 (unshrouded) UI-5129 (shrouded)

- Converts the BNC output to two banana cords for the 850's function generators #2 and #3.



Shown in use with the 850 Universal Interface.

**Resistor Capacitor Inductor Network**

UI-5210

Board components can be used to investigate Kirchhoff's Circuit Laws, Ohm's Law, RC circuits, and A.C. LRC circuit theory with resonant frequencies between 55 kHz and 135 kHz, depending on values used.



**Includes**

- Two inductors: 6.8 mH, 2.5 mH
- Two capacitors: 3900 pF, 560 pF
- Four resistors: 47 kΩ, 3.3 kΩ, and two 1.0 kΩ.

Shown in use with the 850 Universal Interface.

**Order Information**

Resistor Capacitor Inductor Network ..... UI-5210

**8-Pin DIN Extension Cable**

UI-5218

- Use to connect analog sensors to ports A through D on the 850.
- Analog sensors can also be plugged in directly to the 850 ports.



The 1.8 m long Extension Cable allows ScienceWorkshop Sensors to be used even further away from the interface. Multiple cables CAN be used in series. Also works with 750 and 500 interfaces.

**Order Information**

8-Pin DIN Extension Cable ..... UI-5218

**Order Information**

BNC Function Generator Output Cable  
 (Set of 2 unshrouded)..... UI-5119  
 (Set of 2 shrouded)..... UI-5129

# The PASCO 550 Universal Interface...

This powerful interface for Physics connects wirelessly or via USB.

This is the interface with the measurement capability for all types of physics experiments. It features:

- ▶ 2 MHz sampling rate
- ▶ 2 high-speed analog inputs
- ▶ 2 digital inputs for photogates and other timing sensors
- ▶ 2 PASCO PASPORT sensor inputs
- ▶ Signal generator with built-in Voltage and Current sensors.
- ▶ Use with other PASPORT interfaces
- ▶ Connect to computers via USB
- ▶ Bluetooth® classic connectivity

With the 550, your Physics lab is equipped with high-speed data collection, signal generation and power supply, oscilloscope and FFT displays, timers, and more.



## 550 Universal Interface Specifications:

### 2 high-speed analog inputs

**Measurement Range:**  $\pm 10$  V differential input  
**Input Impedance:** 1 M $\Omega$   
**Input Protection:**  $\pm 250$  V continuous  
**Selectable Voltage Gain:** X1, X10, X100  
**Resolution:** 14-bit, 0.12 mV

### 2 Digital Inputs

Digital sensors such as Photogates and Time-of-Flight plug directly into the 550 Interface.

- ▶ Compatible with all ScienceWorkshop digital sensors
- ▶ Sensor Connect Detection
- ▶ 0-5 V TTL
- ▶ Bi-directional

### 2 PASPORT Inputs

Compatible with PASCO's complete line of more than 80 PASPORT sensors.

- ▶ Sample rates depend on sensors

### Signal Generator

**Waveforms:** sine, triangle, square wave, positive and negative ramps, DC

**Frequency Range:** 0.001 Hz to 100 kHz; 1 mHz resolution

**Amplitude Range:**  $\pm 8$  V

**Resolution:** 1.33 mV, 12-bit DAC.

**Max Output Current:** 400 mA at 8 V, over-current detection

**Selectable Voltage Limit**

**Selectable DC Offset**

**Frequency Sweep Function**

**Measure Output Current, Voltage, Frequency,**

**Peak Amplitude**

### Order Information

550 Universal Interface.....UI-5001

*Requires:*

PASCO Capstone Software..... pp. 18-20

or

SPARKvue Software..... p. 21

# Advantages of Using ScienceWorkshop Sensors with the 550 and 850 Universal Interfaces

The 550 and 850 Universal Interfaces are called "Universal" because they are capable of using ScienceWorkshop sensors as well as PASPORT sensors. Although the PASPORT sensors are the newer digital line of sensors, there are advantages to using the older analog technology in the ScienceWorkshop sensors. Here are a few examples:

## 1. High Speed Collision with the Force Sensor (CI-6537) p. 28

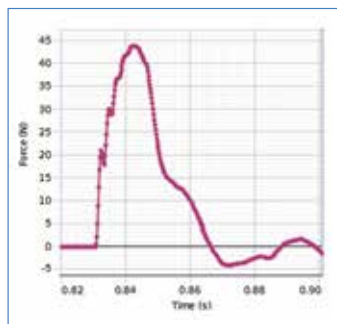

A cart colliding with a Force Sensor with a clay bumper was recorded at 5000 Hz sampling rate. Detail of the collapse of the clay can be seen in the data.

## 2. Detecting the Violet Hydrogen Lines with the High Sensitivity Light Sensor (CI-6604) p. 47

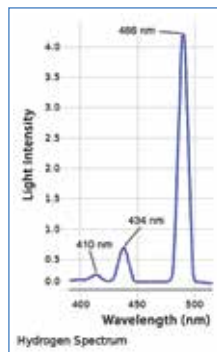

This light sensor has a high gain, which when combined with the interface gain, allows even the dimmest of the Balmer series to be detected.

## 3. Sound FFT Spectrum of a Clarinet Note with the Sound Sensor (CI-6506B) p.57

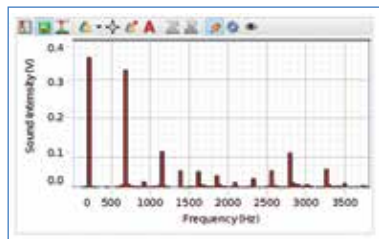

This FFT of a note being played on a clarinet was captured at a sample rate of 20 kHz. The waveform can also be seen on an oscilloscope in Capstone software.



## 4. Pressure Oscillations in Air with the Absolute Pressure Sensor (CI-6532A) p. 40

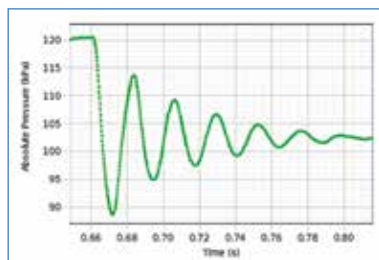

At a sample rate of 5000 Hz, the oscillations of a piston in a cylinder of gas are recorded, allowing the student to determine the ratio of specific heats of the gas.



## 5. LRC Circuit with the Voltage Sensor (UI-5100) p.50

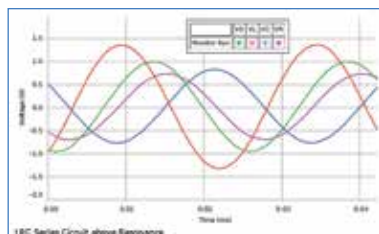

This oscilloscope display in PASCO Capstone shows the voltages across several components of an LRC circuit. Sample rates required for this can be as high as 10 MHz.



# AirLink® and SPARKlink® Air

## Capture data remotely inside or outside of the lab.

The AirLink and the 2-port SPARKlink Air allow users to connect any of PASCO's 80+ PASPORT sensors via USB or Bluetooth. When used wirelessly they allow a freedom and range of movement not available with cabled interfaces. They also provide the ability to easily collect data in the field when needed.

The SPARKlink Air is used here with two Angle Sensors, part of the PS-2137 Goniometer System. The data is sent via Bluetooth to the desktop computer and displayed live with the video recorded by the web cam.



**Goniometer Probes**  
The probes are fastened in place using the blue Velcro® straps, and can be positioned to measure the motion of the knee, hip, or elbow.



**Webcam**  
Record live video synced to sensor data.



**Data Playback**  
Play back the synced data and video at normal or slow speed.

### SPARKlink Air

PS-2011



**Includes**

- Two sensor ports
- Built-in temperature and voltage sensors with probes
- USB and Bluetooth Classic connection

**Order Information**

SPARKlink Air .....	PS-2011	
<i>Shown in use with:</i>		
Goniometer.....	PS-2137	p. 67
Additional Goniometer Probe .....	PS-2138	
<i>Required:</i>		
PASCO Capstone Software.....	pp. 18-20	

### SPARKlink Air Charging Station

PS-2577



Conveniently store and charge up to five SPARKlink Air interfaces with a single power source.

*SPARKlink Air sold separately.*

**Order Information**

SPARKlink Air Charging Station .....	PS-2577
--------------------------------------	---------

### AirLink

PS-3200



**Includes**

- One built-in PASPORT sensor port
- USB and Bluetooth 4.0 connection
- USB cable

**Order Information**

AirLink.....	PS-3200
--------------	---------

### 10-port USB Charging Station

PS-3501



Charge up to 10 wireless sensors via USB cable, included with the sensor.

*(Go to pasco.com for more info.)*

**Order Information**

10-port USB Charging Station .....	PS-3501
------------------------------------	---------

# Low Price Wireless Sensors Simple to Use: Just Connect and Go

- ▶ No interface required
- ▶ No wires to tangle
- ▶ Logging capability
- ▶ Bluetooth® 4.0 connects seamlessly in the software

What makes these wireless sensors special is the ability to pair them with the computer from within our data collection software (PASCO Capstone or SPARKvue). There is no extra confusion introduced by having to manipulate the computer through its operating system. Simply turn on the wireless sensor and it appears on the screen in a list with the sensor closest to the computer listed first. This makes it easy to distinguish your sensors from those belonging to nearby groups.

**NEW** **Wireless Colorimeter and Turbidity** (See p.60)  
PS-3215



**NEW** **Wireless Weather Sensor with GPS** (See p.72)  
PS-3209



**NEW** **Wireless Exercise Heart Rate Sensor** (See p.66)  
PS-3207



**NEW** **Wireless Hand-Grip Heart Rate Sensor** (See p.67)  
PS-3206



**Wireless Pressure** (See p.43)  
PS-3203



**Wireless Conductivity** (See p. 75)  
PS-3210



**Wireless Force Acceleration** (See p. 29)  
PS-3202



**Wireless Light** (See p. 48)  
PS-3213



Wireless Light (Back view)

**Wireless Temperature** (See p. 46)  
PS-3201



**Wireless pH** (See p. 59)  
PS-3204



**Wireless Voltage** (See p. 52)  
PS-3211



**Wireless Current** (See p. 52)  
PS-3212



**Wireless CO<sub>2</sub>** (See p. 63)  
PS-3208



## Order Information

Wireless Colorimeter and Turbidity .....PS-3215  
Wireless Weather Sensor with GPS .....PS-3209  
Wireless Exercise Heart Rate Sensor .....PS-3207  
Wireless Hand-Grip Heart Rate Sensor .....PS-3206  
Wireless Pressure Sensor .....PS-3203  
Wireless Temperature Sensor.....PS-3201

Wireless Conductivity .....PS-3210  
Wireless pH Sensor.....PS-3204  
Wireless Force Acceleration Sensor .....PS-3202  
Wireless AirLink.....PS-3200  
Wireless Voltage.....PS-3211  
Wireless Current.....PS-3212  
Wireless Light.....PS-3213  
Wireless CO<sub>2</sub> .....PS-3208

**Does your Bluetooth need a boost?** 

**USB Bluetooth 4.0 Adapter**  
PS-3500



If you are using our wireless sensors and working on an older Mac® (without Bluetooth Smart connectivity) or if you are using some Windows® computers and Chromebooks™, you will need a USB Adapter.

## Order Information

USB Bluetooth 4.0 Adapter .....PS-3500

See [pasco.com/compatibility](http://pasco.com/compatibility) if you have questions about Bluetooth connectivity.

Designed specifically to collect, display, and analyze data in physics and engineering labs

- ▶ Site license includes student home use
- ▶ For MAC® and Windows™

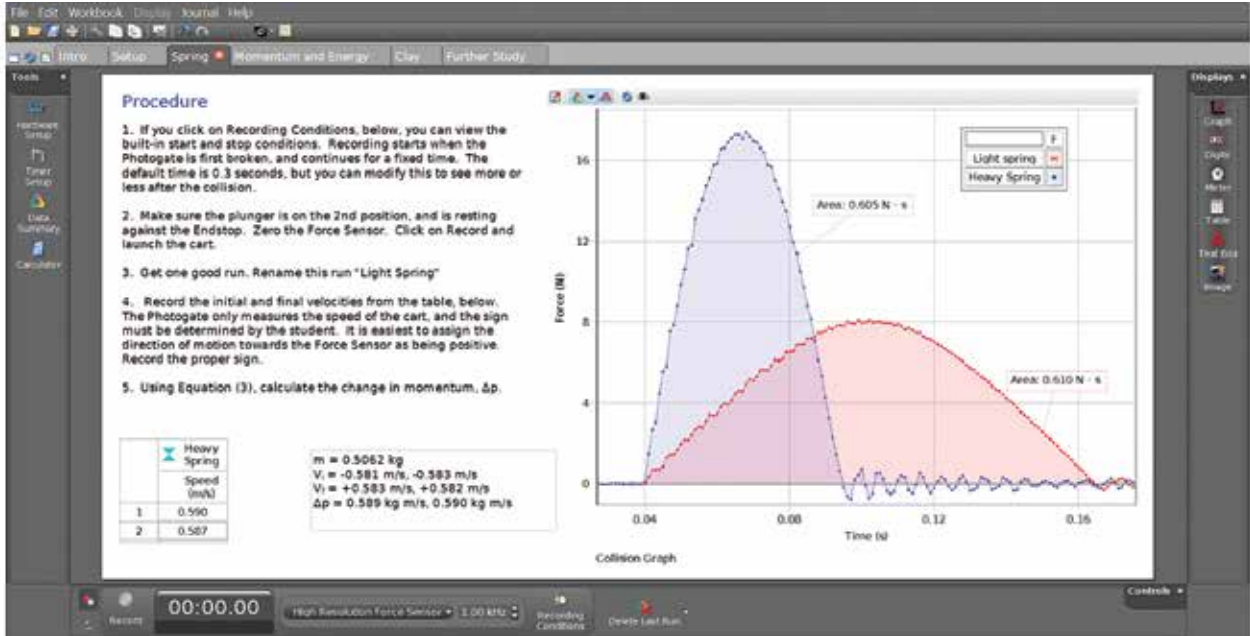

### PASCO Capstone Basic Features

- Auto-ID sensors are recognized when they are plugged in (or identified through Bluetooth®)
- Works with PASPORT, ScienceWorkshop, and new Wireless sensors
- In-app pairing of wireless sensors makes it easy to pick wireless sensors by proximity
- Pre-configured photogate timers

**Sensors**

- Basic displays include graph, table, digits, meter, oscilloscope, text box, picture.
- Make multiple pages with instructions and embedded live graphs.
- Collect data and display it in real time.
- Play back data in real time or slow or high speed.
- Enter data manually – Easy setup in a table
- Lay out displays with smart guidelines.
- Create a Journal by taking snapshots of pages or displays.
- Copy and paste displays into documents.
- Made a mistake? Just hit the Undo button.

**Workbook Format**

- Draw predictions on graphs before taking data.
- Multiple y-axes and/or multiple plot areas
- Perform Quick-Calcs on the graph axis to linearize data.
- Curve-fits report the uncertainties in the parameters.
- Multi-coordinate tool gives y-values wherever it intersects data.

**Graphs**

### Prediction Tools

Predictions are a powerful tool for learning. Students draw what they think the data will look like and then collect the data run and compare it to their prediction. Predictions can be made either point-by-point with a straight line filled between them or free-form.

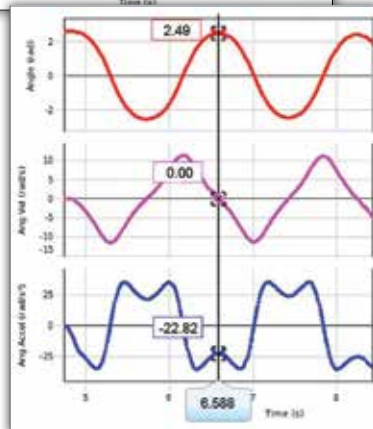
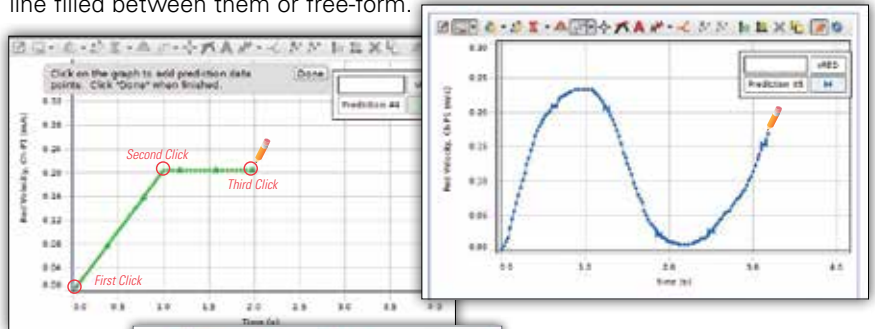

### Multi-Coordinate Tool

This tool finds the values of all the measurements all at once. It's great for showing how the position, velocity, and acceleration are related in oscillations.

**Sensors & Signal Generators**

*PASCO Capstone Advanced Features*

- Calibration wizard for sensors steps you through the calibration process.
- Create your own timers for photogates.
- Configure signal generators with DC offset.
- Scan through a range of frequencies.
- Control the output with a calculation.

**Data Collection Modes**

- Strip chart mode
- Start and stop conditions on time and sensor measurements
- FFT and oscilloscope
- Histogram
- Manual data collection: Keep sensor data points with click of button. See page 20 for details.
- Analyze video and display velocity and acceleration vectors on the video.
- Sync movies with sensor data.

**Data Analysis**

- Exclude or delete selected data points from analysis.
- Create models using the calculator.
- Calculated columns in tables
- Error bars
- Weighted linear fit that takes into account error bars
- More complex curve fits such as damped sine, Gaussian, sine series, and user-entered fits
- Smooth data directly on a graph with slider tool.
- Calculations involving logic statements and filters

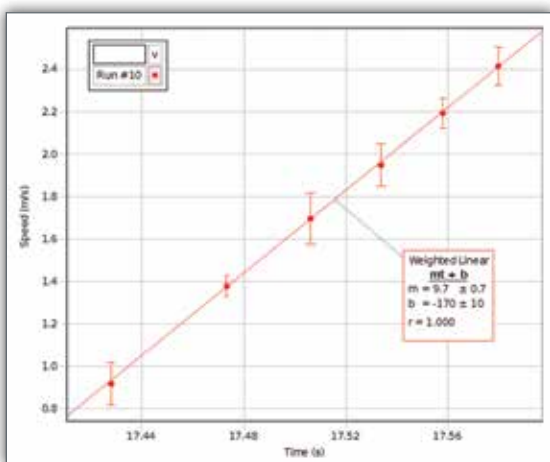

**Error Bars and Weighted Linear Fits**

Graph uncertainties using user-entered error bars, absolute error, or percent error. The weighted linear fit incorporates the error bars.

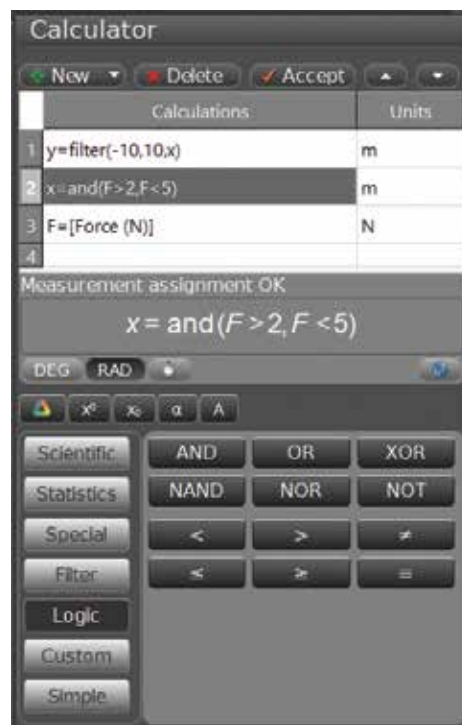

**Calculator**

Sophisticated scientific calculator has statistics, calculus, filters, logic functions, and special operations such as amplitude and period.

**Table II: Energy**

Kinetic Energy = 1/2\*(0.5) [Speed (m/s)]<sup>2</sup>

	Run #10	Run #10
	Speed (m/s)	Kinetic Energy (J)
1	0.91765	0.21
2	1.37779	0.47
3	1.69595	0.72
4	1.94795	0.95
5	2.19135	1.20
6	2.41453	1.46

**Versatile Tables**

Calculated columns can be edited directly in the table. Insert or delete columns or change number of decimal places using toolbar buttons. Click and drag columns to rearrange them. Change run colors directly in the table.

**Download The Free Trial**  
[www.pasco.com/Capstone](http://www.pasco.com/Capstone)

**Order Information**

PASCO Capstone Software  
 Single User License..... UI-5401  
 Site License ..... UI-5400

**PASCO capstone™ Software:** *See new Capstone features on pages 4-5.*

- ▶ Study motion in two dimensions
- ▶ Start USB webcam and data collection simultaneously
- ▶ Display velocity and acceleration vectors
- ▶ Auto-track objects
- ▶ Free with PASCO Capstone

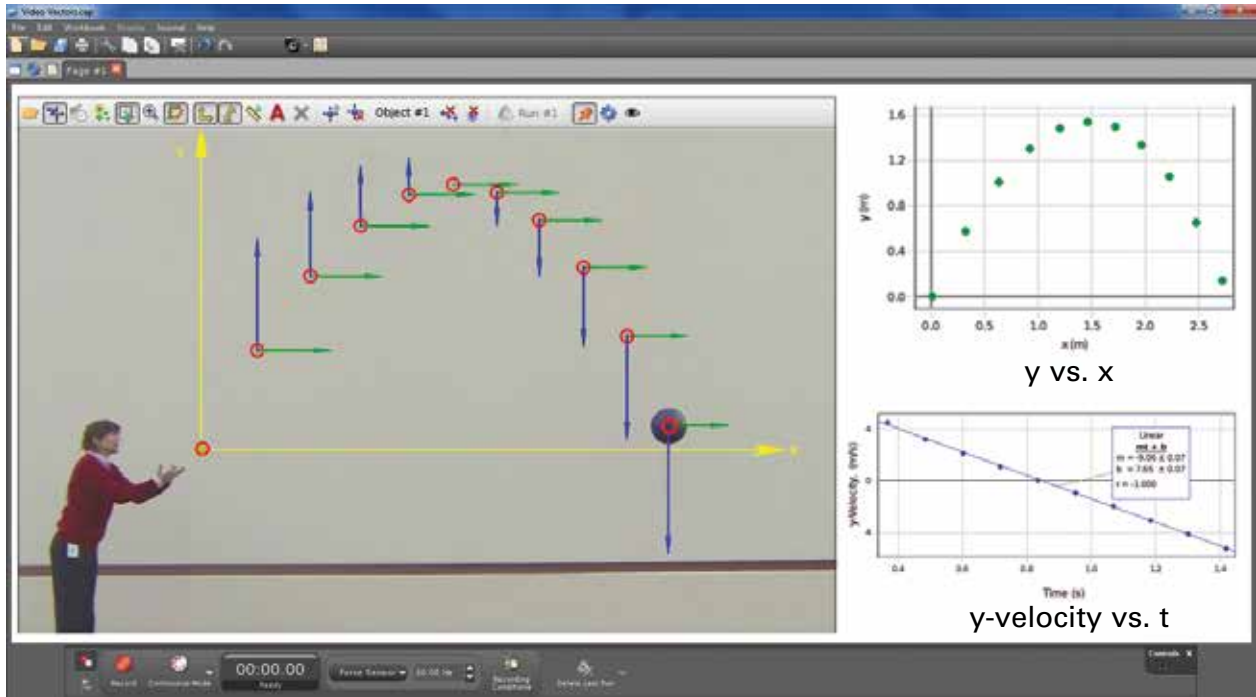

**Video Analysis Features:**

- ▶ Show velocity and acceleration vectors
- ▶ Change to cylindrical coordinates
- ▶ Use magnifier to identify the exact center of the object
- ▶ Use calibration ruler at any time
- ▶ Back up and reposition any point
- ▶ Track more than one object
- ▶ Generate XY data for position, velocity, and acceleration
- ▶ Move the origin of the axes
- ▶ Rotate the axes, even after taking data
- ▶ Make linear measurements in frames or snapshots
- ▶ Measure the radius of circle
- ▶ Measure angles
- ▶ Create annotations
- ▶ Automatic frame-advance after taking a point
- ▶ Set the number of frames that are advanced
- ▶ Change playback rate

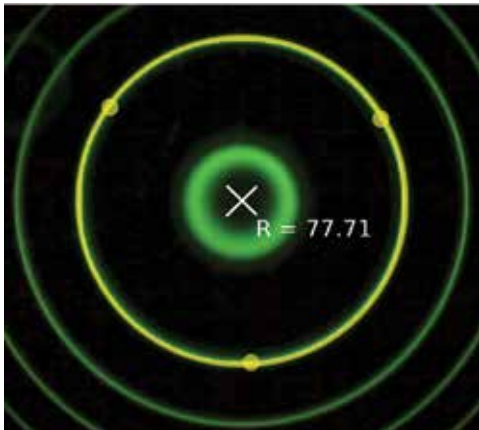

*Special measurement tools allow you to measure the radius of circles or lengths of objects. Shown is a frame from a video of the Zeeman Effect as the magnetic field is increased.*

**Order Information**

PASCO Capstone Software  
 Single User License..... UI-5401  
 Site License ..... UI-5400

# SPARKvue<sup>®</sup> 3.0 Software *Data Collection Software for Mobile Devices and Chromebooks™*

- ▶ Works on Mac®, Windows®, iPad®, and iPhone®, Android™ tablets smart phones, and Chromebook™
- ▶ Simple software suitable for all K-12 sciences

**New features include:**

- Improved Graph, Scope, FFT and Bar Graph displays
- Can directly connect Wireless Sensors to compatible Windows devices
- Easier to change display measurements and units
- New calibration option for wireless CO<sub>2</sub> sensor



## SPARKvue

(single user license) PS-2401  
(site license) PS-2400  
Windows® and Mac®



**Order Information**

SPARKvue (single user license)..... PS-2401  
SPARKvue (site license) ..... PS-2400

## SPARKvue App

Free downloads for iPad, iPhone, Android tablets, phones and Chromebook.

Visit [www.pasco.com/downloads](http://www.pasco.com/downloads)

## Spectrometry Software

*Free software for the PASCO Spectrometer*

- ▶ Works on Mac®, Windows®, iOS, Android™ and Chrome\*

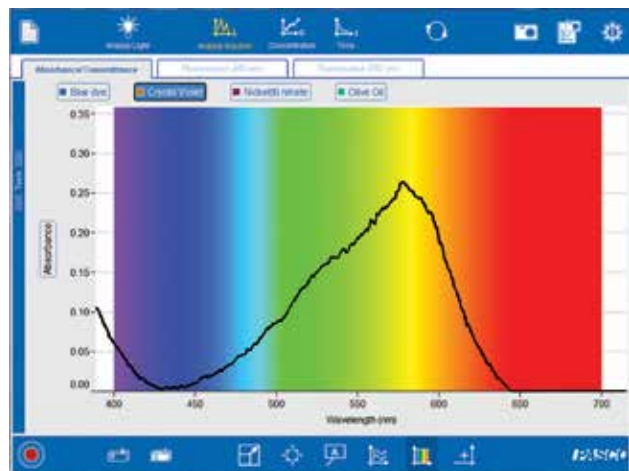

PASCO Wireless Spectrometer (PS-2600)  
See page 62.



\*See our ever-growing list of supported Chromebooks at [pasco.com/spectrometry](http://pasco.com/spectrometry)

## Spectrometry Software

The Wireless Spectrometer comes with PASCO's FREE award-winning Spectrometry software.

Go to [pasco.com/downloads](http://pasco.com/downloads) and click on Wireless Spectrometer

## MatchGraph™ Software

*Free software for learning the meaning of distance and velocity graphs*

- ▶ Works on MAC, Windows, iOS, and Android
- ▶ Kinesthetic learning
- ▶ Move in front of a motion sensor to match the sample graph
- ▶ Match score is displayed
- ▶ Students love to compete while they learn
- ▶ Now works with Smart Carts



## MatchGraph™ Software



Go to [pasco.com/downloads](http://pasco.com/downloads) and click on MatchGraph

## Sensors

PASCO now offers three lines of sensors.

### Wireless Sensors



The award-winning white digital Wireless Sensors connect directly to computers, tablets, and smartphones. They utilize cutting edge Bluetooth® Smart technology. This means lower power consumption plus the freedom and flexibility of wireless. They also provide the same performance as our PASPORT sensors. The Wireless Sensors represent a cost savings since they don't require an interface. And they can be used separately or in conjunction with PASPORT interfaces.

*Compatible interfaces: None required.*

Wireless Force Acceleration Sensor (PS-3202)

Most computing devices will connect directly to PASCO Bluetooth® 4.0 wireless products. Please go to [pasco.com/compatibility](http://pasco.com/compatibility) to determine your direct-connect compatibility. PASCO offers the PS-3500 USB Bluetooth® Adapter for computing devices that do not support direct-connect.

### USB Bluetooth 4.0 Adapter

PS-3500



Most computing devices will connect directly to PASCO Bluetooth® 4.0 wireless products. Please go to [pasco.com/compatibility](http://pasco.com/compatibility) to determine your direct-connect compatibility. PASCO offers the PS-3500 USB Bluetooth® Adapter for computing devices that do not support direct-connect.

#### Order Information

USB Bluetooth 4.0 Adapter ..... PS-3500

### PASPORT Sensors



The blue digital PASPORT sensors contain an analog-to-digital converter and, like the Wireless Sensors, are automatically recognized by PASCO software when connected. Many of the PASPORT sensors contain multiple sensing elements, providing several measurements with a single interface port. The maximum sample rate is sensor-dependent and usually does not exceed 1000 Hz.

*Compatible interfaces: All current PASCO interfaces.*

PASPORT High Resolution Force Sensor (PS-2189)

### PASPORT Sensor Extension Cable

PS-2500



Extends the distance a sensor can reach by 2 m. Two cables CANNOT be connected together, or used on a sensor that already has a cable.

#### Order Information

PASPORT Sensor Extension Cable ..... PS-2500

### ScienceWorkshop Sensors



The black analog ScienceWorkshop sensors are PASCO's original line of sensors. They still provide unique value and use depending on the application. These sensors output a voltage, which is calibrated to correspond to the measurement. The sample rates can be up to 10 MHz depending on the interface used.

*Compatible interfaces: 550 and 850 Universal Interfaces and ScienceWorkshop interfaces. PASPORT interfaces can be used with the proper adapter. See page 41.*

ScienceWorkshop Economy Force Sensor (CI-6746)

### 8-Pin DIN Extension Cable

UI-5218



The 1.8 m long Extension Cable allows ScienceWorkshop Sensors to be used even further away from the interface. Multiple cables CAN be used in series.

#### Order Information

8-Pin DIN Extension Cable ..... UI-5218

# Sensor Index

Sensor Description	Product #	Page #
Acceleration/Altimeter 3-Axis	PS-2136A	35
Accelerometer - Visual	PS-2128	34
Analog Adapter	PS-2158	39
Angle Sensor	PS-2139	67
Barometer/Low Pressure	PS-2113A	43
Blood Pressure	PS-2207	65
Breath Rate	PS-2187	68
Carbon Dioxide Gas (CO <sub>2</sub> )	PS-2110	63
Charge PASPORT	PS-2132	56
<b>CO<sub>2</sub> Gas, Wireless</b>	<b>PS-3208</b>	<b>63</b>
<b>Colorimeter and Turbidity, Wireless</b>	<b>PS-3215</b>	<b>75</b>
Conductivity	PS-2116A	74
<b>Conductivity, Wireless</b>	<b>PS-3210</b>	<b>74</b>
Current	CI-6556	50
Current, High PASPORT	PS-2193	53
<b>Current, Wireless</b>	<b>PS-3212</b>	<b>52</b>
Current Probe	PS-2184	51
Diffusion-Osmosis	ME-6940	42
Digital Adapter	PS-2159	39
Displacement Sensor	PS-2204	33
Dissolved Oxygen Optical	PS-2196	64
Drop Counter (High Accuracy)	PS-2117	58
EKG PASPORT	PS-2111	66
Ethanol	PS-2194	64
Flow, General	PS-2222	41
Flow, General w/Venturi Tube	PS-2225	41
Flow, General w/Pitot Tube	PS-2226	41
Flow Rate/ Temperature	PS-2130	69
Force, ScienceWorkshop	CI-6537	28
<b>Force Acceleration, Wireless</b>	<b>PS-3202</b>	<b>29</b>
Force, High Resolution	PS-2189	29
Force Platform PASPORT	PS-2141	31
Force Platform (2-Axis)	PS-2142	31
Free Fall Adapter	ME-9207B	39
Galvanometer	PS-2160	54
Geiger-Muller	SN-7927A	61
General Science	PS-2168	56
Goniometer	PS-2137	67
Heart Rate		
Exercise, Wireless	PS-3207	66
Hand-Grip, Wireless	PS-3206	67
Humidity/Temp/Dew Point	PS-2124A	70
Ion-Selective Electrodes	Various	60

Sensor Description	Product #	Page #
Light, ScienceWorkshop	CI-6504A	47
Light, Broad Spectrum PASPORT	PS-2150	49
Light, High Sensitivity PASPORT	PS-2176	49
ScienceWorkshop	CI-6604	48
Light, Infrared PASPORT	PS-2148	49
<b>Light, Wireless</b>	<b>PS-3213</b>	<b>48</b>
Load Cell & Amplifier Sets PASPORT	PS-2199	32
Load Cell Amplifiers PASPORT	PS-2198	32
Load Cell, 5N	PS-2201	33
Load Cell, 100N	PS-2200	33
Magnetic Field PASPORT	PS-2112	54
ScienceWorkshop	CI-6520A	55
Magnetic Field (2-Axis)	PS-2162	55
Motion	PS-2103A	24
Motion Sensor II	CI-6742A	24
Oxygen Gas (O <sub>2</sub> )	PS-2126A	63
pH, Flat Probe	PS-3214	59
<b>pH, Wireless</b>	<b>PS-3204</b>	<b>59</b>
Photogate -Accessory	ME-9204B	37
Photogate Head	ME-9498A	37
Photogate/Pulley System	ME-6838A	37
Photogate Smart Gate	PS-2180	36
Polarimeter	PS-2235	62
Pressure - Absolute PASPORT	PS-2107	40
ScienceWorkshop	CI-6532A	40
Pressure - Dual	PS-2181	41
Pressure - Quad	PS-2164	42
Pressure - Relative	PS-2114	43
Pressure/Temperature	PS-2146	42
<b>Pressure, Wireless</b>	<b>PS-3203</b>	<b>43</b>
Rotary Motion PASPORT	PS-2120A	25
ScienceWorkshop	CI-6538	25
Salinity	PS-2195	70
<b>Smart Cart (Red)</b>	<b>ME-1240</b>	<b>98</b>
<b>(Blue)</b>	<b>ME-1241</b>	<b>98</b>
Soil Moisture	PS-2163	73
Sound	CI-6506B	57
Sound Level	PS-2109	57
Spectrometer, Wireless	PS-2600	62
Spirometer	PS-2152	68

Sensor Description	Product #	Page #
Temperature PASPORT	PS-2125	44
ScienceWorkshop	CI-6605A	44
Temperature - Fast Response	PS-2135	45
Temperature - Skin/Surface	PS-2131	45
Temperature - Stainless Steel	PS-2153	45
Temperature - Quad	PS-2143	45
Temperature - Non-contact	PS-2197	46
Temperature - Type K PASPORT	PS-2134	46
Temp/Sound Level/Light	PS-2140	57
<b>Temperature, Wireless</b>	<b>PS-3201</b>	<b>46</b>
Thermocline	PS-2151	69
Time-of-Flight Accessory	ME-6810A	37
Voltage (Shrouded)	UI-5100	51
	UI-5110	51
Voltage/Current	PS-2115	53
<b>Voltage, Wireless</b>	<b>PS-3211</b>	<b>52</b>
Water Quality Colorimeter	PS-2179	75
<b>Weather with GPS, Wireless</b>	<b>PS-3209</b>	<b>72</b>

# Motion

## Motion Sensor

PS-2103A  
**PASPORT**



PASCO's PASPORT Motion Sensor is used to measure position, velocity and acceleration. Ultrasonic pulse-ranging technology has a switch-selectable Standard Beam or Narrow Beam to reject false signals and produce cleaner data. The Motion Sensor sits firmly on a desktop or easily mounts to a rod stand or PASCO Dynamics Track.

### Specifications

**Minimum Range:** 0.15 meters

**Maximum Range:** 8 meters

**Resolution:** 1 mm

**Transducer Rotation:** 360°

**Cable Length:** 1.8 meter

**Near/Far Switch Settings:**

**Narrow:** For distances up to 2 meters to reject false target signals or ignore air track noise.

**Standard:** For longer distances up to 8 meters.

**Mounting Options:**

- 12.7 mm diameter rod or smaller
- Directly to the PASCO Dynamics Track
- Non-skid rubber feet for table mount

### Typical Applications

- ▶ Study conservation of energy and momentum during collisions
- ▶ Monitor the sinusoidal motion of a mass on a spring
- ▶ Measure the motion of large objects, such as students

Measure force applied by spring and resulting velocity of cart.

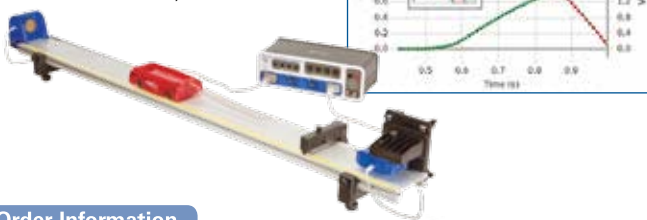

### Order Information

Motion Sensor.....	PS-2103A
<i>Recommended:</i>	
Motion Sensor Guard.....	SE-7256
Magnetic Motion Sensor Bracket.....	PS-2546
Cart Adapter Accessory.....	ME-6743

## Motion Sensor II

CI-6742A  
**ScienceWorkshop**



PASCO's digital ScienceWorkshop Motion Sensor II is used to measure position, velocity and acceleration. Ultrasonic pulse-ranging technology has a switch-selectable Standard Beam or Narrow Beam to reject false signals and produce cleaner data. The Motion Sensor sits firmly on a desktop or easily mounts to a rod stand or PASCO Dynamics Track.

### Specifications

**CI-6538 ScienceWorkshop:**

**Connector:** Dual stereo phone plug for 850, 550, and ScienceWorkshop interfaces.

### Order Information

Motion Sensor II .....	CI-6742A
<i>Recommended:</i>	
Motion Sensor Guard.....	SE-7256
Magnetic Motion Sensor Bracket.....	PS-2546
Cart Adapter Accessory.....	ME-6743
Accessory Cable .....	CI-6748
<i>Allows CI-6742A to be used with CBL/EA100.</i>	

## Elastic Bumper

ME-8998

The Elastic Bumper protects the Motion Sensor from the carts, but doesn't interfere with the ultrasonic pulse.

### Includes

- Two pairs of brackets
- 10 meters of elastic material

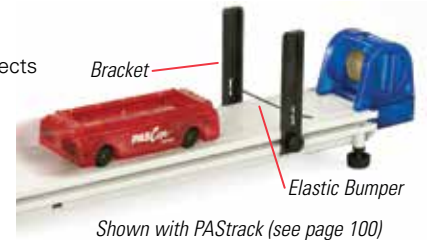

### Order Information

Elastic Bumper .....	ME-8998
----------------------	---------

## Motion Sensor Guard

SE-7256

Use this wire guard to protect the Motion Sensor when dropping objects from above.

### Order Information

Motion Sensor Guard.....	SE-7256
--------------------------	---------



## Magnetic Motion Sensor Bracket

PS-2546

This magnetic bracket allows a Motion Sensor to be easily hung from a drop ceiling. Simply screw the bracket into the 1/4"-20 threads on the sensor and use the included adjustment nut to hold the sensor in the desired orientation.

*The bracket can also be used to hold the Motion Sensor on vertical surfaces such as filing cabinets and magnetic whiteboards.*



### Order Information

Magnetic Motion Sensor Bracket.....	PS-2546
-------------------------------------	---------

## Cart Adapter Accessory

ME-6743

A Motion Sensor can be directly mounted to Dynamics Carts, PAScars or GOcars using the Cart Adapter Accessory. Mounting a Motion Sensor on a cart is ideal for the study of relative motion.

*The adjustment knob on the bracket allows the Motion Sensor to face any direction.*



### Order Information

Cart Adapter Accessory .....	ME-6743
------------------------------	---------

## Rotary Motion

PS-2120A **PASPORT**

### Rod Stand Clamp

Clamp can also be mounted on the right or left side of the sensor.

Slot for Linear Motion Accessory

Thumb Screw

Three-step Pulley

Platform for Mounting PASCO Super Pulley

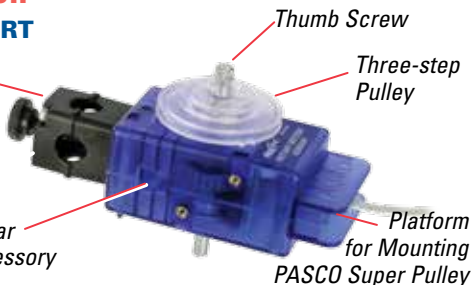

PASCO's PASPORT Rotary Motion Sensor is the most versatile position and motion-measuring devices available for the physics lab. Measure angle and angular velocity or measure distance and linear velocity using the rack or the pulley. These sensors are also bi-directional, indicating the direction of motion.

The 6.35 mm diameter, dual ball-bearing shaft extends from both sides of the unit and provides an excellent platform for rotational experiments. The rod clamp (which can be attached on three sides of the sensor) allows the unit to be mounted in almost any orientation. A three-step pulley and a mount for the PASCO Super Pulley make it easy to perform torque experiments.

### Specifications

**Three-step Pulley:** 10 mm, 29 mm and 48 mm diameter  
**Sensor Dimensions:** 10 cm x 5 cm x 3.75 cm, 6.35 mm diameter shaft

### Rotary Motion:

**Resolution:** 0.09°/0.0078 mm

Maximum Speeds: 30 revs/sec

Optical Encoder: bidirectional, indicates direction of motion; 4000 divisions/rev

### Conservation of Angular Momentum

The angular speed of the disk decreases when the ring is dropped onto the disk.

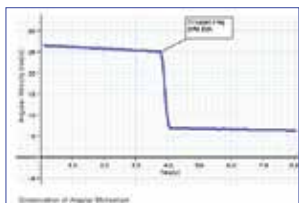

## Linear Accessory Kit

CI-6688A

Includes rod clamp and solid aluminum rack.

Shown in use measuring magnetic field from a coil.

See page 55.



### Order Information

Linear Accessory Kit.....CI-6688A

## Mini Rotational Accessory

CI-6691

Use the Mini Rotational Accessory to study rotational inertia, pendulum oscillations, and conservation of angular momentum. See page 157.

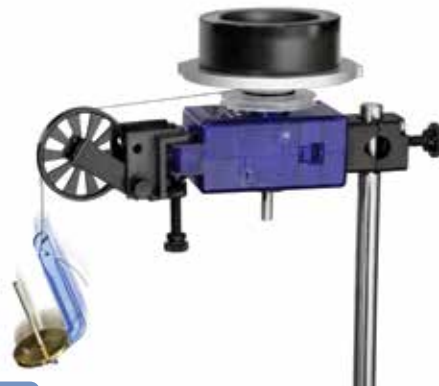

### Order Information

Mini Rotational Accessory.....CI-6691

### Order Information

Rotary Motion Sensor ..... PS-2120A

Recommended:

Linear Accessory Kit.....CI-6688A

Three-step Pulley.....CI-6693

## Rotary Motion

CI-6538

### ScienceWorkshop



PASCO's digital ScienceWorkshop Rotary Motion Sensor is the most versatile position and motion-measuring devices available for the physics lab. Measure angle and angular velocity or measure distance and linear velocity using the rack or the pulley. These sensors are also bi-directional, indicating the direction of motion.

The 6.35 mm diameter, dual ball-bearing shaft extends from both sides of the unit and provides an excellent platform for rotational experiments. The rod clamp (which can be attached on three sides of the sensor) allows the unit to be mounted in almost any orientation. A three-step pulley and a mount for the PASCO Super Pulley make it easy to perform torque experiments.

### Specifications

**CI-6538 ScienceWorkshop:**

**Resolution:** 1°/0.087 mm and 0.25°/0.022 mm (software selectable)

**Maximum Speeds:** 13 rev/sec at 1° resolution (360 data points/revolution); 3.25 rev/sec at 0.25° resolution (1440 data points/revolution)

**Optical Encoder:** Bidirectional, indicates direction of motion

**Connector:** Dual stereo phone plug for 850, 550, and ScienceWorkshop interfaces

### Order Information

Rotary Motion Sensor ..... CI-6538

Recommended:

Linear Accessory Kit.....CI-6688A

Three-step Pulley.....CI-6693

# How the Rotary Motion Sensor is used

## Chaos/Driven Harmonic Accessory

CI-6689A

Magnetically damped pendulum disk for studying exponential damping, driven harmonic motion, and chaos

See page 167.



**Order Information**

Chaos/Driven Harmonic Accessory .....CI-6689A

## Centripetal Force

ME-9821

The Centripetal Force Sensor mounts onto the Rotary Motion Sensor to directly measure Centripetal Force.

See page 163.



**Order Information**

Centripetal Force .....ME-9821

## Educational Spectrophotometer

OS-8539

60:1 gear ratio of rotating disk and pin gives the Rotary Motion Sensor a higher resolution for spectrophotometry.



See pages 274-275

**Order Information**

Educational Spectrophotometer System.....OS-8539

## Ballistic Pendulum Accessories

Ballistic Pendulum Accessory ME-9892

Mini Launcher Ballistic Pendulum Accessory ME-6829



See page 130-131.

Turn your PASCO Launcher into a Ballistic Pendulum using the Rotary Motion Sensor.

**Order Information**

Ballistic Pendulum Accessory.....ME-9892

Mini Launcher Ballistic Pendulum Accessory .....ME-6829

## Track String Adapter

ME-6569



## Dynamics Track Mount

CI-6692



Use a Rotary Motion Sensor to measure position of a cart on a Dynamics Track.



See page 92-93.

**Order Information**

Track String Adapter .....ME-6569

Dynamics Track Mount.....CI-6692

## Linear Translator

OS-8535A

The Rotary Motion Sensor's built-in gear system accepts the geared rack to create a high-resolution linear translator for optics.

See page 269.



### Order Information

Linear Translator ..... OS-8535A

## Gyroscope

ME-8960

Use two Rotary Motion Sensors to measure both the nutation and precession of this demonstration gyroscope.

See page 168-169.



### Order Information

Gyroscope ..... ME-8960

## Heat Engine

TD-8572A

Use a Rotary Motion Sensor with PASCO's Heat Engine Apparatus to graph a real Heat Engine Cycle.

See page 198.



### Order Information

Heat Engine ..... TD-8572A

## Polarization Analyzer

OS-8533A

The drive belt allows the Rotary Motion Sensor to measure the rotation of the polarizer.

See page 262.



### Order Information

Polarization Analyzer ..... OS-8533A

## How to Select the Right Force Sensor or Load Cell for you

Part #	Sensor	Interface	Purpose
CI-6537	Force	550/850 interfaces or legacy 500/750 interfaces	<ul style="list-style-type: none"> <li>• Higher sample rates up to 10 MHz (depends on interface)</li> <li>• Extra strain gauges cancel side-loads</li> </ul>
PS-2189	High Resolution Force	Any PASPORT interface, 550, or 850	<ul style="list-style-type: none"> <li>• More sensitive: 0.002 N resolution</li> <li>• Maximum sample rate is 1000 Hz</li> <li>• Good for Hooke's Law and Newton's Third Law</li> </ul>
PS-3202	Wireless Force Acceleration	No interface required	<ul style="list-style-type: none"> <li>• Bluetooth 4.0 required</li> <li>• Same resolution as PS-2104</li> <li>• Measures force, acceleration, angular velocity</li> <li>• Maximum sample rate 1000 Hz</li> </ul>
PS-2141	Force Platform	Any PASPORT interface, 550, or 850	<ul style="list-style-type: none"> <li>• Measures normal force only</li> <li>• Good for measuring hang time when a person jumps.</li> </ul>
PS-2142	2-Axis Force Platform	Any PASPORT interface, 550, or 850	<ul style="list-style-type: none"> <li>• Measures normal force and tangent force</li> <li>• Excellent for measuring human walking</li> </ul>
PS-2200	100 N Load Cell	Any PASPORT interface, 550, or 850	<ul style="list-style-type: none"> <li>• Requires PS-2198 Six Load Cell Amplifier or PS-2206 Dual Load Cell Amplifier</li> <li>• For measuring loads in bridges or other structures made with PASCO Structures System</li> </ul>
PS-2201	5 N Load Cell	Any PASPORT interface, 550, or 850	<ul style="list-style-type: none"> <li>• Requires PS-2198 Six Load Cell Amplifier or PS-2206 Dual Load Cell Amplifier</li> <li>• Used with PASCO Structures System to measure smaller loads or to measure accelerations during bridge vibrations</li> </ul>

### Force Sensor

CI-6537 **ScienceWorkshop**

▶  $\pm 50$  N range

▶ High sample rate

PASCO's durable, reliable Force Sensor was designed specifically for the student physics lab. Wide-range, high-frequency response and a low noise transducer help generate excellent impulse graphs, smooth harmonic motion data, and more. The sensor's special strain gauge consistently generates the same output for the same force and is designed to minimize side loads. Damping materials reduce vibrations caused by collisions without affecting results. Any dynamics cart accessories can be mounted on top of the Force Sensor.



#### Specifications

**Force Range:** -50 to +50 N

**Resolution:** 0.03 N or 3.1 grams

**Zero (Tare) Function:** Push-button

**Force-overload Protection:** Mechanical stop prevents forces of more than 50 N from damaging the sensor

**Pin Configuration:** 8-pin DIN plug

Mounts on standard 12.7 mm support rods

**Maximum Sample Rate:** Depends on interface

#### Order Information

Force Sensor ..... CI-6537

## High Resolution Force

PS-2189 **PASPORT**

- ▶ 0.002 N resolution
- ▶ Dynamic over-sampling



Although this Force Sensor has the same case as the PS-2104 and can perform all of the same experiments, it has much better resolution. And the dynamic variable over-sampling greatly reduces the measurement noise at low sample rates.

### Specifications

**Range:**  $\pm 50$  N

**Measurement Resolution:** 0.002 N or 0.2 g

**Zero (Tare) Function:** Push-button

**Max Sample Rate:** 1000 Hz

**Force Overload Protection:** Up to 75 N without damage

*The High Resolution Force Sensor has 10 times the resolution of the PS-2104, and can measure changes in force of less than 0.01 N.*

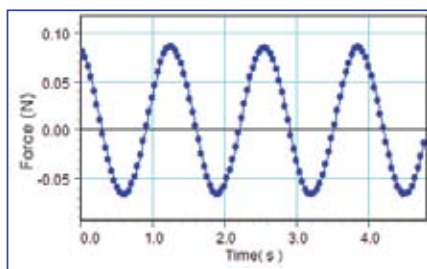

Graph shows force data for the oscillation of a mass and spring system.

*The digital design of the PS-2189 results in very little drift, ensuring that the tare will hold for hours. You can use this force sensor as a pan balance for long-term experiments, like investigating the evaporation of liquids such as alcohol or liquid nitrogen, and the sublimation of dry ice!*



### Order Information

High Resolution Force Sensor .....	PS-2189	
<i>Shown in use with:</i>		
Force Sensor Balance Stand.....	CI-6460	
Mass and Hanger Set.....	ME-8979	p. 187
Spring Set.....	ME-8999	p. 156

## Wireless Force Acceleration Sensor

PS-3202

- ▶ Freedom from wires
- ▶ Measure force, acceleration, and rotation



The Wireless Force Acceleration Sensor allows for live data collection in a moving frame of reference. You can mount the sensor on a rotating platform or on a moving cart to measure forces and accelerations of the constantly changing dynamic system. The wireless design offers improved measurements without a cable affecting the experiment outcome.

### Features

- ▶ Bluetooth® and USB connectivity
- ▶ Logging
- ▶  $\pm 50$  N
- ▶ 3-axis accelerometer
- ▶ 3-axis gyroscope
- ▶ Finger-holes
- ▶ Built-in rod clamp

### Specifications

**Force Range:**  $\pm 50$  N

**Force Resolution:** 0.03 N

**Accuracy:** 0.1 N

**Acceleration Range:**  $\pm 16$  g

**Battery:** Rechargeable lithium-polymer

**Logging:** Yes

**Bluetooth:** BT 4.0



### Includes (1 each)

- Eye bolt
- Thumb screw
- Bumper
- Rechargeable lithium-polymer battery
- USB connector

### Order Information

Wireless Force Sensor ..... PS-3202

# Force Sensor Accessories

## Force Bracket

ME-6622

The Force Bracket with bumpers mounts the PASCO Force Sensor directly to a dynamics track. It includes 5 collision attachments for the Force Sensor and conveniently stores each attachment on the bracket itself.

Using any of these attachments, the bracket serves as an excellent support or target for collision studies using the Force Sensor.

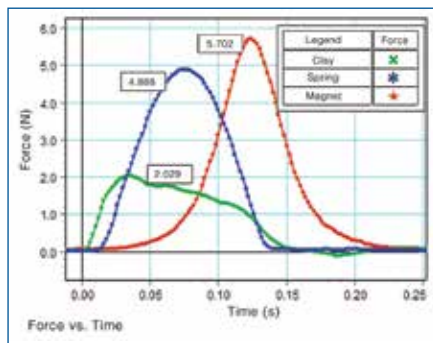

Force vs. time data for a clay, spring and magnet.



### Includes

- Spring Bumpers (2) (different spring constants)
- Magnetic Bumper (1)
- Rubber Bumper (1)
- Clay Cup for Inelastic Collisions (1) (clay included)
- #0 Phillips Head Screwdriver (to attach to Force Sensor)

### Order Information

Force Bracket..... ME-6622

## Bumper Accessory Set

ME-9884



This set of bumpers can be used with any PASCO Force Sensor to perform both elastic and inelastic collisions. The standard hook for each Force Sensor can be easily removed and replaced with any of these bumpers. Use a spring and a cup for elastic collisions. Combine two cups with clay to explore inelastic collisions.

### Includes

- Stiff Spring
- Light Spring
- Empty Cup (2)
- Modeling Clay

### Order Information

Bumper Accessory Set..... ME-9884

## Magnetic Bumper Set

ME-9885A



This set of magnetic bumpers can be used with any PASCO Force Sensor to perform elastic collisions without any contact. The bumpers screw directly into the beam of the sensor. They can also be used with the Force Bracket (at left).

### Includes

- Magnetic Bumper (2)

### Order Information

Magnetic Bumper Set..... ME-9885A

## Rocket Engine Test Bracket

ME-6617

### ▶ A perfect supplement for rocketry studies

With the Rocket Engine Test Bracket attached to a Force Sensor (Science-Workshop or PASPORT), students can measure and graphically display the impulse of Estes™ and other model rocket engines. A perfect supplement for rocketry studies. Accommodates rocket engine sizes A, B, C and D.

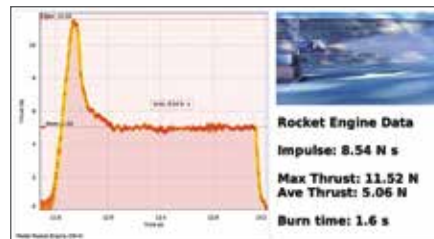

For outdoor use only.

The Force Sensor must always be securely mounted when a rocket engine is fired. We suggest the PASCO Large Rod Stand and 45 cm Rod (p. 176).

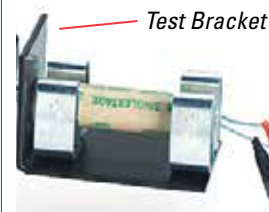

### Order Information

Rocket Engine Test Bracket..... ME-6617

## Force Platform

PS-2141

- ▶ Rugged design
- ▶ Force overload protection



The sturdy glass-filled nylon platform is supported by four force beams that combine to measure the total force on the platform. The Force Platform has two loops on the side to hang it on a wall.

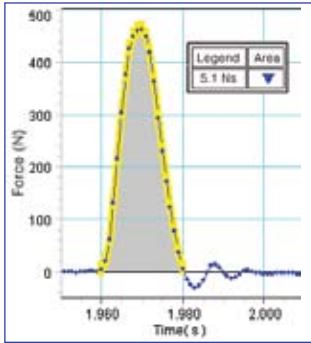

Impulse data for a bouncing playground ball.



### Typical Applications

- ▶ Determine "hang time" by jumping up from the platform, then landing on it
- ▶ Measure impulse and maximum force when jumping
- ▶ Use two Force Platforms to investigate Newton's Third Law as two students push against each other
- ▶ Measure the normal force on a person riding in an elevator
- ▶ Use a Motion Sensor and a bouncing ball to compare the impulse and change in momentum as the ball collides with the platform

### Specifications

**Range:** -1100 N to +4400 N  
**Platform Size:** 35 cm x 35 cm  
**Zero (tare) Function:** Push-button Force Overload Protection  
**Max Sample Rate:** 1000 Hz (2000 Hz with the Xplorer GLX or 850 Interface)  
**Resolution:** 0.1 N  
**Mass:** 4 kg (without handles)

### Order Information

Force Platform.....PS-2141  
**Recommended:**  
 Handle Set.....PS-2548

## 2-Axis Force Platform

PS-2142

- ▶ Large jumping and landing surface



The 2-axis Force Platform has a second plate that rides on rollers on the base force platform to measure the force parallel to the platform. There are a total of five force beams: four corner beams to measure the normal force and a fifth beam to measure the parallel (sideways) force.

### Typical Applications

- ▶ Measure the sideways force during a broad jump
- ▶ Measure the normal and parallel forces on a wall as a ladder leans against the wall
- ▶ Measure the normal and parallel forces as a person walks or runs across the platform
- ▶ Pull an object across the platform and measure the normal and frictional forces

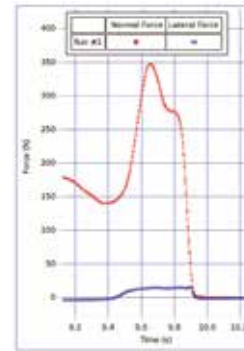

The normal and parallel forces are recorded as the girl jumps off the platform.



### Specifications

**Range:** -1100 N to +4400 N (in normal direction)  
 -1100 N to +1100 N (in parallel direction)  
**Platform Size:** 35 cm x 35 cm  
**Platform Mass:** 6.4 kg (without handles)  
**Zero (tare) Function:** Push-button Force Overload Protection  
**Max Sample Rate:** 1000 Hz (2000 Hz with the Xplorer GLX or 850 Interface)  
**Resolution:** 0.1 N

### Order Information

2-Axis Force Platform.....PS-2142  
**Recommended:**  
 Handle Set.....PS-2548

*Developed in cooperation with Nancy Beverly, Associate Professor of Physics at Mercy College, Dobbs Ferry, New York.*

## Force Platform Handle Set

PS-2548

Confirm Newton's Third Law by pushing on a Force Platform using two sets of handles (available separately). Handles bolt onto the Force Platform and can be mounted on either side or both sides.



By standing on a 2-Axis Force Platform while pushing against the wall with a 1-Axis Force Platform, a real-life statics problem can be analyzed.



### Includes

- Set of sturdy metal handles (2)

### Order Information

Force Platform Handle Set.....PS-2548

## Force Platform Structures Bracket

ME-6988A

See page 33.

### Includes

- Brackets (2)
- Screws (4)



### Order Information

Force Platform Structures Bracket.....ME-6988A

# Load Cells

## Choice of Load Cell Amplifiers:

### Load Cell Amplifier (6 ports)

PS-2198  
**PASPORT**



This Load Cell Amplifier can accommodate up to six load cells and only needs a single port on any PASCO interface to connect to the USB port on a computer. This is useful for doing an extensive analysis of a bridge by inserting six load cells at various points in the structure to see if theory matches reality.

The amplifier accepts either the 100N load cell or the 5N load cell or a combination of both. The maximum data sample rate is 500 Hz for each port.

Display of the forces measured using the four load cells shown.

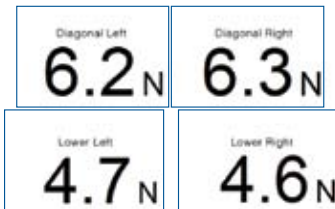

The top two numbers are the left and right diagonals and the bottom two numbers are the left and right horizontal forces.

Shown in use with Structures Systems Truss Set (ME-6990). See page 142.

#### Includes

- Load Cell Amplifier
- 100 N Load Cell (4)

#### Order Information

Load Cell Amplifier (6 ports).....	PS-2198
<i>Required for Use:</i>	
Load Cell 100N.....	PS-2200
Load Cell 5N.....	PS-2201

#### Also Available

Load Cell and Amplifier Set.....	PS-2199
----------------------------------	---------



#### Set Includes

- Load Cell Amplifier
- Load Cells 100N (4)
- Instruction manual

### Dual Load Cell Amplifier

PS-2205  
**PASPORT**



This amplifier is for applications where only one or two load cells are needed, such as measuring the force on the track at the top of a roller coaster loop. If you only want to examine the forces in a bridge one at a time, you can move a single load cell around in the bridge.

The Amplifier accepts either the 100N load cell or the 5N load cell or a combination of both. The maximum data sample rate is 1000 Hz for each port.

Use load cells to measure force exerted on car at the top of the loop.

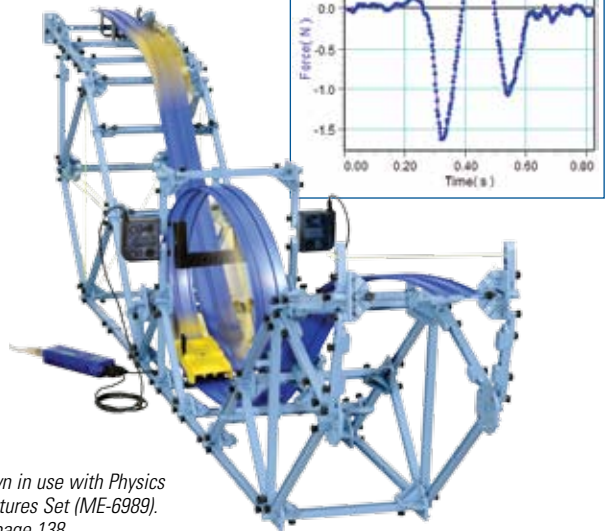

Shown in use with Physics Structures Set (ME-6989). See page 138.

#### Includes

- Dual Load Cell Amplifier

#### Order Information

Dual Load Cell Amplifier .....	PS-2205
<i>Required for Use:</i>	
Load Cell 100N.....	PS-2200
Load Cell 5N.....	PS-2201

#### Also Available

Load Cell and Dual Amplifier Set.....	PS-2206
---------------------------------------	---------



#### Set Includes

- Dual Load Cell Amplifier
- Load Cell 100N (1)

Two ranges of load cells

**Load Cell 100N**

PS-2200

**Load Cell 5N**

PS-2201



Load cells are available in two different ranges:  $\pm 100$  N and  $\pm 5$  N. Both types of load cells can be used with the same amplifier in any combination. The semi-transparent case lets students see the strain gauge and beam inside.



I-Beams key into the load cell and are fastened with thumb screws.

**Specifications (PS-2200)**

- Range:** -100 N to +100 N
- Accuracy:**  $\pm 1\%$  ( $\pm 1$  N)
- Resolution:** 0.02 N
- Safe Overload:** -150 N to +150 N

**Specifications (PS-2201)**

- Range:** -5 N to +5 N
- Accuracy:**  $\pm 1\%$  ( $\pm 0.05$  N)
- Resolution:** 0.001 N
- Safe Overload:** -7.5 N to +7.5 N

**Order Information**

- 100 N Load Cell..... PS-2200
- 5 N Load Cell..... PS-2201

Measure support forces with a Force Platform

**Force Platform Structures Bracket**

ME-6988A

Measure the support forces of a crane by connecting it to a Force Platform (PS-2141) using the special Force Platform Structures Bracket (ME-6988A). The Force Platform is supported by four individual load cells that combine to measure the total vertical force on the platform. These four readings can also be viewed separately, to measure the unequal forces on the crane supports.



Tower Crane (2.3 m tall) built using the Large Structures Set (ME-7003) See page 139.

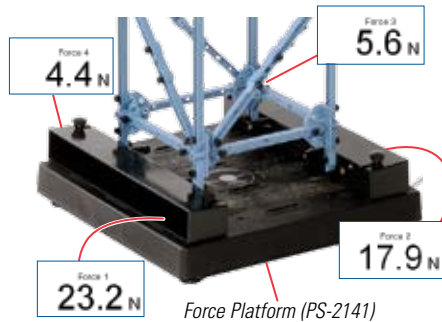

Force Platform (PS-2141)

**Includes**

- Brackets (2)
- Screws (4)



**Order Information**

- Force Platform Structures Bracket..... ME-6988A
- Shown in use with:
- Force Platform..... PS-2141 p. 31
- Large Structures Set..... ME-7003 p. 144

Measure bridge deflection with a Displacement Sensor

**Displacement Sensor**

PS-2204

The Displacement Sensor measures the travel of a spring-loaded indicator pressed against a bridge as the bridge is loaded. It consists of a PASPORT sensor that plugs into the included Digital Indicator, a digital travel indicator that has its own digital LED readout and can be used as a stand-alone device. When the PASPORT sensor is plugged into an interface, the reading can be recorded.



See page 136 for more uses.

**Specifications**

- Maximum Travel:** 10 mm
- Maximum Sample Rate:** 5 Hz
- Resolution:** 0.013 mm (0.0005 in)

**Includes**

- Sensor
- Bracket
- Dial Gauge



**Order Information**

- Displacement Sensor..... PS-2204

Shown in use with:

- Hooked Mass Set..... SE-8759 p. 187
- Small "A" Base..... ME-8976 p. 178
- Steel Rod 60 cm long (threaded)..... ME-8977 p. 176

# Force Acceleration

## Visual Accelerometer

PS-2128

### PASPORT

- ▶ LEDs indicate direction and magnitude of acceleration
- ▶ 1-axis acceleration sensor



The Visual Accelerometer provides acceleration data and visual clues that allow students to better understand the concept of acceleration. The sensor features 10 high output, wide-angle LEDs that indicate the magnitude and direction of acceleration. The case of the sensor fits directly into a dynamics cart, and features ties for pendulum motion and a pass-through so the sensor can be thrown vertically along a rope.

The Visual Accelerometer features three fixed ranges, an auto-scale and a peak-hold option. The peak-hold mode stores the maximum acceleration experienced by the sensor after a countdown appears on the LEDs. The zero button on the sensor negates the effect of changing the orientation of the sensor.

The Visual Accelerometer can also be used in stand-alone mode. While away from the computer, the LEDs give students a meaningful, visual measurement of acceleration.

### Typical Applications

- ▶ Real-time measurement of acceleration during simple harmonic motion
- ▶ Measure acceleration due to gravity
- ▶ Measure acceleration of a cart on an inclined plane
- ▶ Discover the acceleration of an elevator

See page 104 for more applications.

### Specifications

**Ranges:**  $\pm 1.0 \text{ m/s}^2$ ,  $\pm 5.0 \text{ m/s}^2$ ,  $\pm 20 \text{ m/s}^2$

**Accuracy:**  $0.2 \text{ m/s}^2$

**Resolution:**  $0.01 \text{ m/s}^2$

**Max Sample Rate:** 100 Hz

**Includes** (1 each)

- Sensor extension cable (1)
- Three AA batteries



For freefall studies, the bottom of the Visual Accelerometer has a channel that accepts a cord or small rope.

### Order Information

Visual Accelerometer.....PS-2128

## Wireless Force Acceleration Sensor



PS-3202

Capable of measuring force, acceleration, and rotation, this sensor is ideal for experiments involving rotating platforms, moving carts, spring oscillations, collisions, and impulse. The wireless design offers improved measurements without a cable affecting experiment outcome. Finger-holes support handheld applications, or mount it onto a cart or rod.

### Features

- ▶ Bluetooth® and USB connectivity
- ▶ Logging
- ▶ +/- 50 N
- ▶ 3-axis accelerometer
- ▶ 3-axis gyroscope
- ▶ Finger-holes
- ▶ Built-in rod clamp

**Includes** (1 each)

- Eye bolt
- Rechargeable lithium-polymer battery
- Thumb screw
- USB connector
- Bumper

### Specifications

**Force Range:** +/- 50 N

**Force Resolution:** 0.03 N

**Accuracy:** 0.1 N

**Max Sample Rate:** 1000 Hz (wireless)

**Acceleration Range:**  $\pm 16 \text{ g}$

**Battery:** Rechargeable lithium-polymer

**Logging:** Yes

**Bluetooth:** BT 4.0

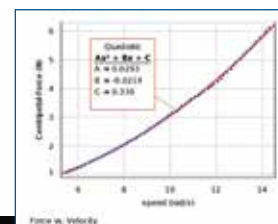

The Wireless Force Acceleration Sensor can measure both the centripetal force and, using its gyroscope, the angular velocity of the rotating platform.

### Order Information

Wireless Force Acceleration Sensor.....PS-3202

### 3-Axis Acceleration/Altimeter

PS-2136A **PASPORT\***

- ▶ 3-axis acceleration data to 500 Hz
- ▶ 16 g on each axis
- ▶ 10 cm resolution altitude data



This one acceleration sensor does it all! Measure acceleration in all three dimensions, as well as changes in altitude. Measure acceleration data up to 500 Hz. Dynamic variable over-sampling automatically reduces the measurement noise at slower sampling rates.

#### Typical Applications

- ▶ Attach to a dynamics cart for the study of Newton's Laws.
- ▶ Investigate centripetal acceleration on a rotating platform
- ▶ Sports physics
- ▶ Roller coaster amusement park physics

#### Specifications

Acceleration for each axis 16 g with 0.002 g resolution  
 10 cm altitude resolution  
 Acceleration readout in g or m/s/s.

#### Sample Rate:

Max sample rate for acceleration: 500 Hz  
 Max sample rate for acceleration with simultaneous altitude data: 100 Hz  
 Max data rate for altitude: 20 samples/second

#### Five Simultaneous Measurements:

Acceleration in x, y and z axes, resultant acceleration and altitude.

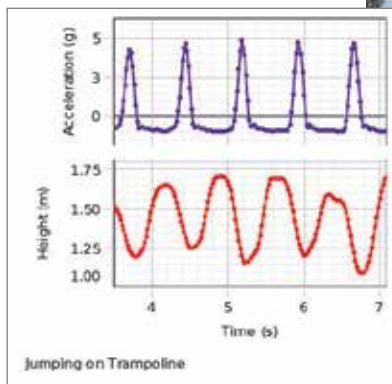

#### Trampoline

Altitude and acceleration are simultaneously measured on a trampoline.

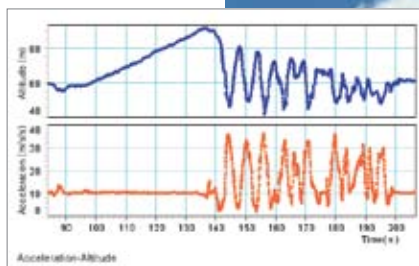
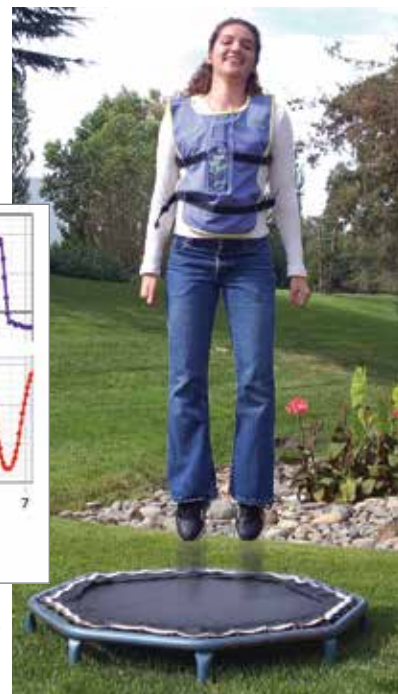

#### Roller Coaster

Acceleration and altitude data from a roller coaster.

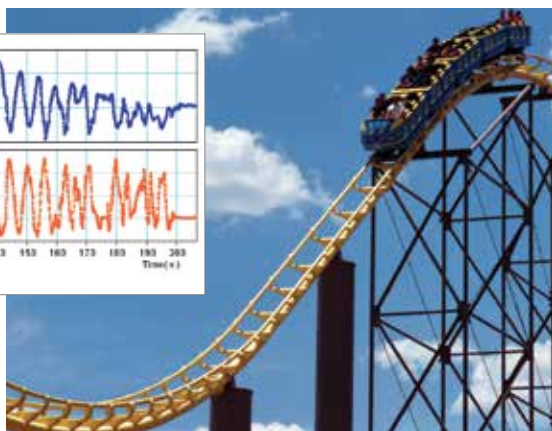

#### Weight Lifting

During a bench press, the weight lifter accelerates and then decelerates the weights. The acceleration is zero at the top of the lift where the weights are held at rest. This graph shows the resultant acceleration calculated from all three axes, so the orientation of the sensor does not affect the measurement. The acceleration due to gravity has been subtracted out.

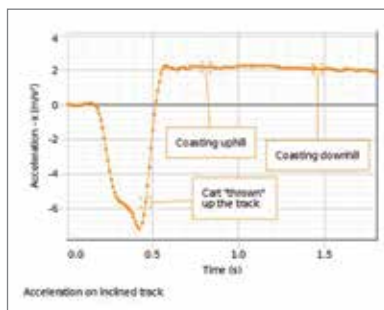
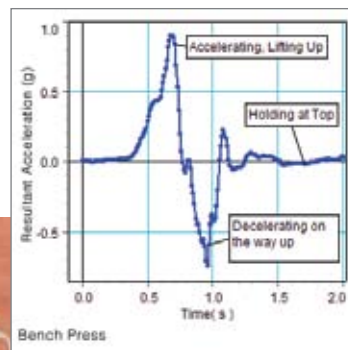

#### Inclined Track

The cart acceleration parallel to the track is measured as the cart is "thrown" up the incline and allowed to coast up and back down the track.



#### Order Information

3-Axis Acceleration/Altimeter .....PS-2136A  
 Shown in use with:  
 550 Universal Interface.....UI-5001

# Smart Gate

## Smart Gate... *It's four photogates in one!*

PS-2180 **PASPORT**

- ▶ Dual Photogate beams
- ▶ Laser switch
- ▶ Photogate Tape Slot
- ▶ Daisy chain auxiliary Photogate or Time-of-Flight

The Smart Gate has dual Photogate beams spaced at 1.5 cm to accurately measure speed. Built-in laser switch (when used with any laser) allows you to time objects too large to fit through the standard Photogate. Other features include a slot for Photogate Tape, and an auxiliary port for an additional Photogate or the Time of Flight Accessory.

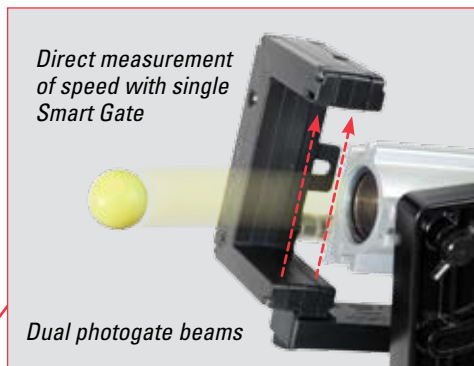
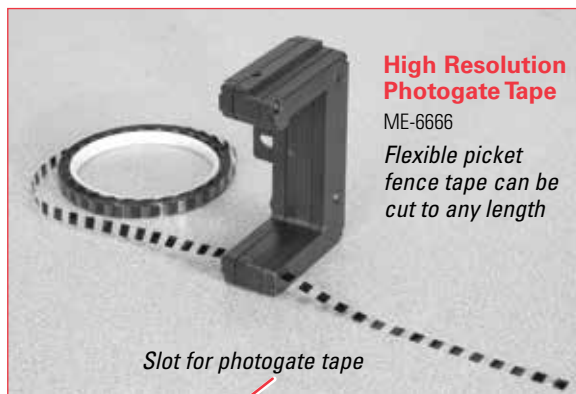

**Includes**

- Smart Gate
- Interface Cord



**Order Information**

Smart Gate .....	PS-2180	
<i>Recommended:</i>		
Time-of-Flight Accessory .....	ME-6810A	p. 37
High Resolution Photogate Tape .....	ME-6666	p. 38
<i>Required:</i>		
PASPORT Interface		

*\*See page 24 for the complete information about PASPORT and ScienceWorkshop sensors.*

## Smart Gate System

PS-3701

Needs only one PASPORT connection. Photogate daisy-chains to Smart Gate.

**Includes** (1 each)

- Smart Gate PS-2180
- Photogate Head ME-9498A



**Order Information**

Smart Gate System..... PS-3701

## Smart Gate Pulley System

PS-3702

The Super Pulley attaches directly to the Smart Gate, providing a simple, low-friction system to measure position, velocity and acceleration. Additionally, with the pulley removed, the photogate can be used to perform standard photogate experiments.

**Includes** (1 each)

- Smart Gate PS-2180
- Super Pulley ME-9450A
- Super Pulley Rod ME-8736



**Order Information**

Smart Gate Pulley System..... PS-3702

The Photogates and Time-of-Flight Accessory on this page plug directly into the auxiliary port on the Smart Gate.

**Photogate Head**

ME-9498A

**Specifications**

- Photogate Width:** 7.5 cm
- Fall Time:** < 50 ns
- Spatial Resolution:** < 1 mm
- Timing Resolution:** 0.1 millisecond
- Connector:** Stereo phone plug



**Order Information**

Photogate Head .....	ME-9498A
<i>Recommended:</i>	
Photogate Stand .....	ME-9805

**Accessory Photogate**

ME-9204B

Includes both a Photogate Head and a Photogate Stand for flexible experiment design. The Photogate Stand is also sold separately.



**Order Information**

Accessory Photogate.....	ME-9204B
Photogate Stand .....	ME-9805

**Time-of-Flight Accessory**

ME-6810



**Typical Applications**

- ▶ Find Time-of-Flight for a ball shot from a Projectile Launcher
- ▶ Conduct freefall experiments

The Time-of-Flight Accessory is designed primarily for freefall or projectile experiments. When an object hits the plate, a signal is sent to the interface. Note: When used with the Projectile Launcher, a photogate is used to start the timer and the 20' extension cable is recommended.

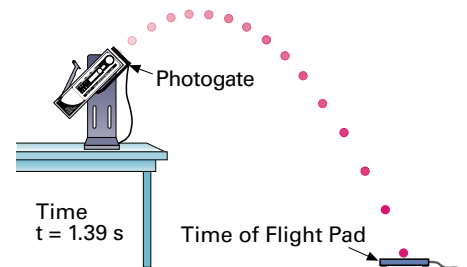

**Order Information**

Time-of-Flight Accessory .....	ME-6810A
--------------------------------	----------

**Photogate/Pulley System**

ME-6838A

**Specifications**

- Pulley:**
  - Rotational inertia:  $1.8 \times 10^{-6}$  kg m<sup>2</sup>;
  - Coefficient of friction:  $< 7 \times 10^{-3}$ ;
  - Diameter: 5 cm, Mass: 5.5 g
- Photogate:**
  - Width: 7.5 cm; Fall time: < 50 ns;
  - Spatial resolution: < 1 mm
- Timing Resolution:** 0.1 millisecond
- Connector:** Stereo phone plug



**Includes**

- Photogate Head
- Super Pulley with Rod

**Order Information**

Photogate/Pulley System .....	ME-6838A
-------------------------------	----------

**Photogate Pendulum Set**

ME-8752

The Photogate Pendulum Set is a unique set of pendula that have exactly the same shape and size, but different masses. These pendula are ideal for use with photogates due to their cylindrical shape. One pendulum each of brass, plastic, wood and aluminum is included.



Photogate not included.

**Order Information**

Photogate Pendulum Set .....	ME-8752
------------------------------	---------

## Photogates Fences and Tape

The sensors on this page are digital sensors that plug directly into ScienceWorkshop, 550, and 850 Universal interfaces. To use the sensors with a PASPORT interface, a Digital Adapter is required.

### Photogates and Fences

ME-9471A

When used with the computer for data recording, display, and analysis, the photogate/pulley timing system can provide a wide range of time, speed, and velocity measurements. The photogates mount to the dynamics track using the provided brackets. The picket fences provided mount directly to the dynamics carts.

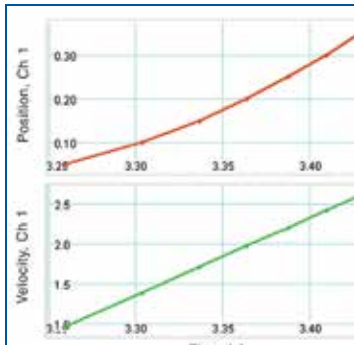

Position and velocity graphs are obtained using a Picket Fence and Photogate.



#### Includes

- Photogate Heads (2)
- Photogate Brackets (2)
- Picket Fences (2)
- Super Pulley with attachment screw (attaches Super Pulley to Photogate)
- Pulley Mounting Rod

#### Order Information

Photogates and Fences .....ME-9471A

#### Individual Components:

Photogate Head .....	ME-9498A	p. 37
Photogate Brackets (2) .....	ME-9806	p. 117
Cart Picket Fences (2) .....	ME-9804	
Super Pulley .....	ME-9450A	p. 137
Pulley Mounting Rod .....	SA-9242	p. 137

**Required for use with SPARKlink Air or AirLink:**

Digital Adapter .....PS-2159 p. 39

### Large Picket Fence

ME-9377A

Conduct free fall experiments by dropping this Picket Fence through the PASCO Photogate.

The distance from the leading edge of each black bar to the leading edge of the next black bar is 5.0 cm. The Picket Fence has eight black bars and is 40 cm long.



#### Order Information

Large Picket Fence .....ME-9377A

### Cart Picket Fences (set of 2)

ME-9804



#### Order Information

Cart Picket Fences (set of 2).....ME-9804

### Smart Timer Picket Fences (set of 2)

ME-8933

See *Smart Timer* on pages 120-121.

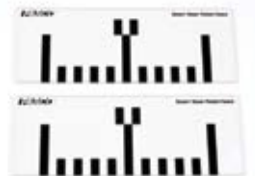

#### Order Information

Smart Timer Picket Fences (set of 2) .....ME-8933

### Photogate Tape (Hi Res)

ME-6666

The High Resolution Photogate Tape, has a distance of 1 cm between edges for more data points during high velocity or acceleration phenomena.



#### Order Information

High Resolution Photogate Tape.....ME-6666  
 Shown in use with:  
 Smart Gate .....PS-2180

The sensors on this page are digital sensors that plug directly into ScienceWorkshop, 550, and 850 Universal interfaces. To use the sensors with a PASPORT interface, a Digital Adapter is required.

## Time-of-Flight Accessory

ME-6810A



**NEW  
DESIGN**

The Time-of-Flight Accessory has a new rugged case. When an object hits the plate, a signal is sent to the interface. Note: When used with the Projectile Launcher, a photogate is used to start the timer and the 20' extension cable is recommended.

### Typical Applications

- ▶ Find Time-of-Flight for a ball shot from a Projectile Launcher
- ▶ Conduct freefall experiments

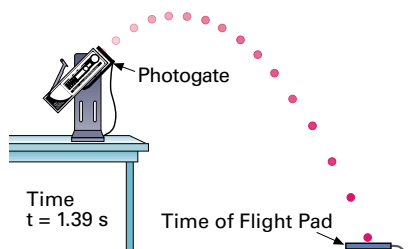

### Order Information

Time-of-Flight  
Accessory .....ME-6810A  
*Required for use with SPARKlink Air or AirLink:*  
Digital Adapter .....PS-2159

## Phone Jack Extender Cable

PI-8117



This six meter phone jack-to-phone jack extension cord can be used with any Photogate/Timing accessory.

### Order Information

Phone Jack Extender Cord  
(20' cable).....PI-8117

## Freefall Adapter

ME-9207B



When the steel ball is dropped from the release mechanism, the computer automatically starts timing. When the ball hits the receptor pad, timing stops. Timer measurements of "g" are accurate and repeatable.

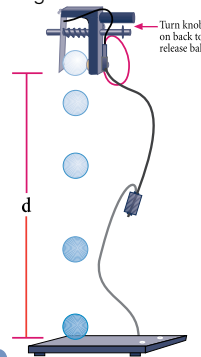

### Order Information

Freefall Adapter .....ME-9207B  
*Required for use with SPARKlink Air or AirLink:*  
Digital Adapter .....PS-2159

## G-M Tube/Power Supply

SN-7927A

- ▶ Ideal general purpose nuclear sensor



The G-M Tube/Power Supply senses alpha, beta, and gamma radiation. Power for the tube is supplied through the connection to an interface that supplies an operating voltage of +5 V.

### Specifications

**Sensitivity:** Beta, gamma, alpha  
**Count Detection:** Audio signal  
**Window Thickness:** 1.5 to 2 mg/cm<sup>2</sup>, mica  
**Gas Filling:** Neon, argon, and halogen  
**Starting/Operating Voltage for Tube:**  
450 VDC/500 VDC  
**Dead Time:** 80  $\mu$ s

### Order Information

G-M Tube/Power Supply .SN-7927A  
*Required for use with SPARKlink Air or AirLink:*  
Digital Adapter ..... PS-2159

## Digital Adapter

PS-2159



- ▶ Required for counting and timing sensors
- ▶ Allows digital ScienceWorkshop sensors to be used with PASPORT interfaces

The Digital Adapter is required when photogates, timing and counting sensors are used with any PASPORT interface. Each Digital Adapter accommodates two sensors at once. Each port on the Digital Adapter automatically detects a connection and initiates a selection of pre-configured or user-defined options. Several Digital Adapters can be used simultaneously when required. See next page for a list of counting/timing sensors that require a Digital Adapter.

### Specifications and Special Features

**2  $\mu$ s resolution** for counting and timing  
**1  $\mu$ s resolution** for motion sensing  
Two 1/4" stereo phone jacks

### Order Information

Digital Adapter .....PS-2159

## Analog Adapter

PS-2158



- ▶ Use your black ScienceWorkshop sensors with blue PASPORT interfaces
- ▶ No need to buy new sensors

Use an Analog Adapter to connect ScienceWorkshop sensors with an 8-pin or 5-pin DIN connector such as:

- Colorimeter (CI-6747)
- Current (CI-6556)
- Force (CI-6537)
- Force, Economy (CI-6746)
- Infrared (CI-6628)
- Light (CI-6504A)
- Light, High-Sensitivity (CI-6604)
- Light, UVA (CI-9784)
- Magnetic Field (CI-6520A)
- Pressure Sensor-Absolute (CI-6532A)
- Sound (CI-6506B)
- Temperature (CI-6605A)
- Temperature, High Accuracy (CI-6525)

### Order Information

Analog Adapter .....PS-2158

## Pressure

## How to select the right Pressure Sensor for you

Part #	Sensor	Interface	Purpose
CI-6532A	Absolute Pressure	550/850 interfaces or legacy 500/750 interfaces	<ul style="list-style-type: none"> <li>Higher sample rates up to 10 MHz (depends on interface)</li> <li>Measures up to 700 kPa</li> <li>Fast enough for Ratio of Specific Heats</li> </ul>
PS-2107	Absolute Pressure	Any PASPORT interface, 550, or 850	<ul style="list-style-type: none"> <li>Measures up to 700 kPa</li> <li>Good for Absolute Zero experiment</li> </ul>
PS-2181	Dual Pressure	Any PASPORT interface, 550, or 850	<ul style="list-style-type: none"> <li>Measures up to 200 kPa</li> <li>Maximum sample rate 1000 Hz</li> <li>Best for heat engine experiment</li> <li>Fast enough for Ratio of Specific Heats</li> </ul>
PS-2164	Quad Pressure	Any PASPORT interface, 550, or 850	<ul style="list-style-type: none"> <li>Measures up to 200 kPa</li> <li>Maximum sample rate 1000 Hz</li> <li>For Venturi experiments</li> </ul>
PS-2146	Absolute Pressure/Temp	Any PASPORT interface, 550, or 850	<ul style="list-style-type: none"> <li>Measures up to 200 kPa</li> <li>Maximum sample rate 100 Hz</li> <li>Excellent for Absolute Zero and Ideal Gas Law</li> </ul>
PS-3203	Wireless Pressure	No interface required	<ul style="list-style-type: none"> <li>Bluetooth 4.0 required</li> <li>Measures up to 400 kPa</li> <li>Maximum sample rate 1000 Hz</li> <li>Weather; Ideal Gas Law</li> </ul>
PS-2114	Gauge Pressure	Any PASPORT interface, 550, or 850	<ul style="list-style-type: none"> <li>Measures up to 10 kPa</li> <li>Maximum sample rate 20 Hz</li> <li>Measure respiration rates</li> </ul>

## Absolute Pressure

CI-6532A ScienceWorkshop



- ▶ Measure absolute pressure up to seven atmospheres
- ▶ Includes syringe for Gas Laws
- ▶ High sample rate

The Absolute Pressure Sensor measures the gas pressure in a container or the surroundings. Includes a 20 cc syringe and quick connect tubing for investigating the Gas Laws. The sensor's wide range makes it an excellent general purpose pressure device.

## Typical Applications

- ▶ Measure chemical reaction rates
- ▶ Verify Gas Laws (Ideal, Charles', Boyle's)
- ▶ Study Vapor Pressure vs. Temperature

## Specifications

**Pressure Range:** 0 to 700 kPa**Reference Vacuum Pressure:** 40 mTorr**Number of Pressure Ports:** One**Pin Configuration:** 8-pin DIN plug on case**Maximum Sample Rate:** Depends on interface

## Order Information

Absolute Pressure Sensor .....CI-6532A

## Absolute Pressure

PS-2107 PASPORT



- ▶ Measure absolute pressure up to seven atmospheres
- ▶ Includes syringe for Gas Laws

The Absolute Pressure Sensor measures the gas pressure in a container or the surroundings. Includes a 20 cc syringe and quick connect tubing for investigating the Gas Laws. The sensor's wide range makes it an excellent general purpose pressure device.

## Typical Applications

- ▶ Measure chemical reaction rates
- ▶ Verify Gas Laws (Ideal, Charles', Boyle's)
- ▶ Study Vapor Pressure vs. Temperature

## Specifications

**Range:** 0 to 700 kPa**Accuracy:**  $\pm 2$  kPa**Resolution:** 0.1 kPa**Maximum Sample Rate:** 200 Hz**Repeatability:** 1 kPa

The Absolute Pressure Sensor is used in a Boyle's Law experiment in which a syringe is compressed.

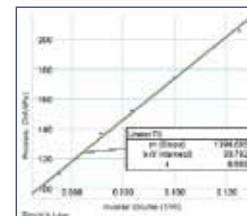

## Order Information

Absolute Pressure Sensor .....PS-2107

## Dual Pressure

PS-2181 **PASPORT**



The Dual Pressure sensor is capable of reading two absolute pressures, one gauge pressure, or one differential pressure. Dynamic variable over-sampling automatically reduces the measurement noise at low sampling rates. Sample rates up to 1000 Hz make studies of both transient and steady-state pressure possible. Includes quick-connect tubing.

### Typical Application

- ▶ Measure pressure in Heat Engine (TD-8572). See pages 346-347.
- ▶ Measure pressure drops in pipes



Instrument your pipe network with the Pressure Taps connected to the Dual Pressure Sensor (PS-2181). See pages 172-173.

### Specifications

**Absolute Pressure:** 0 to 200 kPa, 0.01 kPa resolution at 10 Hz and 1 kPa repeatability  
**Differential Pressure:** ±100 kPa, 0.01 kPa resolution at 10 Hz and 1 kPa repeatability  
**Maximum Sample Rate:** 1000 Hz

### Order Information

Dual Pressure Sensor..... PS-2181

## Pressure Taps

ME-2224



### Order Information

Pressure Taps (set of 6)..... ME-2224

## General Flow Sensor

PS-2222 General Flow Sensor Only  
 PS-2225 General Flow Sensor with Venturi Tube  
 PS-2226 General Flow Sensor with Pitot Tube  
**PASPORT**

The General Flow Sensor determines fluid velocity in air or water by measuring the difference in pressure between the two input tubes. Either the Venturi Tube or the Pitot Tube must be connected to the General Flow Sensor. The type of fluid (air or water) being used is selectable in the software.

### Applications

The Venturi Tube is used in a pipe network that carries water or air. The Pitot Tube is used in an open water channel or in air.

### Specifications

**Pressure Range:** 0 to 50 kPa  
**Pressure Accuracy:** ± 2.5% of Full Scale (0 to 85°C)  
**Resolution:** 0.2% of Full Scale  
**Venturi Range:** 0 to 84 gpm (water); 0 to 773 gpm (air)  
**Venturi Accuracy:** ± 2 gpm (water); ± 2.5 cf/min (air)  
**Pitot Range:** 0 to 9.98 m/s (water); 0 to 92.1 m/s (air)



### Order Information

General Flow Sensor with Venturi Tube.....PS-2225  
 General Flow Sensor with Pitot Tube.....PS-2226

#### Required:

PASPORT Interface ..... pp. 10-11  
 PASCO Capstone Software ..... pp. 18-20

#### Also available separately:

General Flow Sensor without Probes ..... PS-2222  
 Venturi Tube.....ME-2220  
 Pitot Tube.....ME-2221



## Venturi Tube

ME-2220



The Venturi Tube is made of clear PVC so the water can be seen flowing through it. It has a constriction and two pressure ports with tubing attached. The Venturi Tube is connected to the General Flow Sensor by the matching couplers. The General Flow Sensor measures the difference in fluid pressure between the two different cross-sectional areas and the software does a calculation to convert this pressure difference into a velocity or volumetric flow rate. The Venturi Tube slip joints are designed to be glued into any 3/4" PVC pipe network.

## Pitot Tube

ME-2221



The Pitot Tube is designed to be placed in the air flow or water flowing in a channel. The General Flow Sensor, connected to the Pitot Tube, measures the pressure difference between the fluid inlet and the static side taps of the Pitot Tube and the software calculates the fluid velocity from the pressure difference.

See page 172–173 for more applications.

# Pressure/Temperature

## Quad Pressure

PS-2164 **PASPORT**



The 4-port Quad Pressure sensor is capable of reading up to four absolute pressures, or two gauge pressures, or two differential pressures. Dynamic variable over-sampling automatically reduces the measurement noise at low sampling rates. Sample rates up to 1000 Hz make studies of both transient and steady-state pressure possible. Includes quick-connect tubing.

### Typical Application

- ▶ Study pressure through a fluid circuit

### Specifications

**Absolute Pressure:** 0 to 200 kPa, 0.01 kPa resolution at 10 Hz and 1 kPa repeatability (displays pressure in kPa, N/m<sup>2</sup>, and psi)

**Differential Pressure:** ±100 kPa, 0.01 kPa resolution at 10 Hz and 1 kPa repeatability (displays pressure in kPa, N/m<sup>2</sup>, and psi)

**Maximum Sample Rate:** 1000 Hz

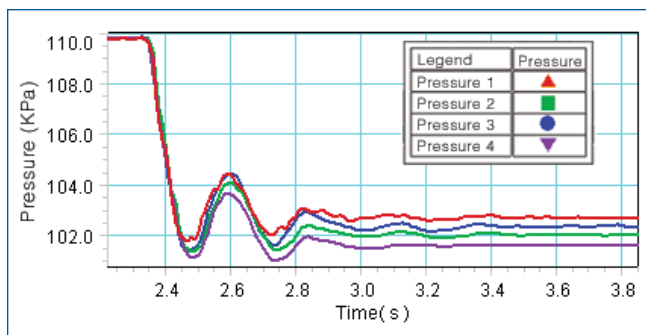

The pressure at various points in a Venturi tube decreases as the water flow is turned on. Pressure variability due to cross-sectional area and fluid friction are readily seen in the data.

### Order Information

Quad Pressure Sensor .....PS-2164  
 Venturi Tube.....ME-2220 p. 41

## Absolute Pressure/Temperature

PS-2146 **PASPORT**



This combination sensor is specifically designed for use in studying gas laws. The included thermistor temperature probe has both a fast response and very low thermal mass.

### Typical Applications

- ▶ Extrapolate absolute zero
- ▶ Explore Gas Laws (Ideal, Charles', Boyle's)

### Specifications

**Pressure:** 0 to 700 kPa with ±2 kPa accuracy, 0.1 kPa resolution and 1 kPa repeatability (displays pressure in kPa, N/m<sup>2</sup>, and psi)

**Maximum Sample Rate:** 100 Hz

**Temperature with Included Fast Response Probe:** -10 to 70°C with ±0.5°C accuracy (displays Temperature in °C, K and °F)

**Sensor Extension Cable:** Included

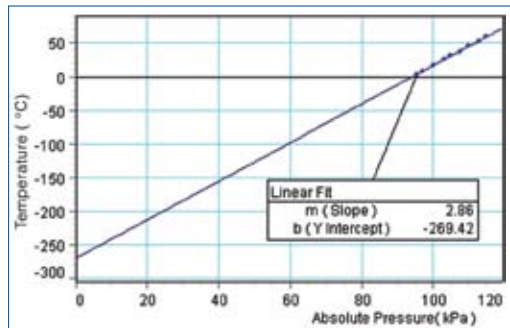

Extrapolating Absolute Zero



Measure pressure and temperature of air in the sphere.

### Order Information

Absolute Pressure/Temp Sensor .....PS-2146  
**Recommended:**  
 Absolute Zero Sphere.....TD-8595 p. 197  
 Ideal Gas Law Apparatus.....TD-8596A p. 196

## Wireless Pressure Sensor

PS-3203

With the new Wireless Pressure Sensor you can make accurate and consistent measurements of gas pressure, regardless of ambient conditions, and explore how chemical reactions affect gas pressure. In combination with a wireless Temperature Sensor, you can study the empirical gas laws.



*A test tube, piece of steel wool, and a Wireless Pressure Sensor are all you need to have your students calculate the amount of oxygen in the air.*

*With these sensors, students can easily study gas laws.*

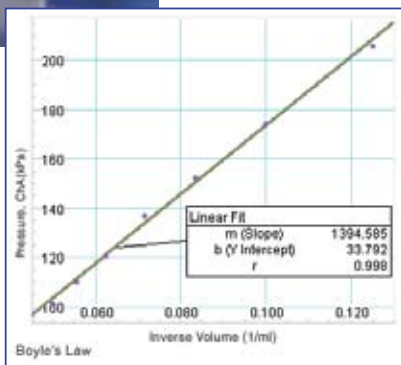

### Specifications

**Range:** 0-400 kPa

**Resolution:** 0.1 kPa

**Accuracy:** ±1 kPa

**Battery:** Rechargeable lithium-polymer included

**Logging:** Yes

**Bluetooth:** BT 4.0

**USB cable** for charging

### Includes

- 2 feet of polyurethane plastic tubing
- 1 female barbed luer lock
- 1 tube connector
- 1 60cc syringe
- 2 male barbed luer locks
- USB connector

*Wireless sensors connect directly to most classroom devices.*

### Order Information

Wireless Pressure Sensor ..... PS-3203

## Relative Pressure

PS-2114 **PASPORT**

The Relative Pressure Sensor measures gas pressure compared to atmospheric pressure, which is commonly known as gauge pressure. Includes quick connect tubing for a variety of pressure activities. The limited pressure range of the sensor provides excellent accuracy and resolution for measuring small pressure changes.



### Typical Applications

- ▶ Heat Engine Cycles
- ▶ Measure pressure changes in a Venturi Tube
- ▶ Conduct air foil studies

### Specifications

**Range:** 0 to 10 kPa

**Accuracy:** ±0.1 kPa

**Maximum Sample Rate:** 20 Hz

**Resolution:** 0.001 kPa

**Repeatability:** 0.01 kPa

*Pressure is measured for various water column heights.*



*Water Reservoir (ME-8594) is sold separately on page 179.*

*The graph below shows water pressure (relative) versus depth.*

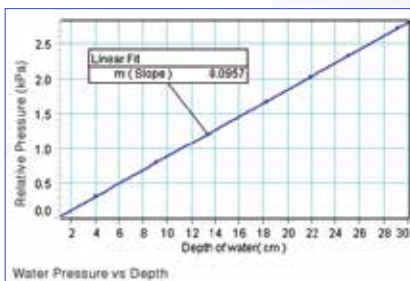

### Order Information

Relative Pressure Sensor ..... PS-2114

## Temperature

## How to select the right Temperature Sensor/Probe

Part #	Sensor	Interface	Purpose
CI-6605A	Temperature	550/850 interfaces or legacy 500/750 interfaces	<ul style="list-style-type: none"> <li>Higher sample rates: maximum depends on the probe</li> <li>General purpose for water/air from freezing to boiling</li> </ul>
PS-2125	Temperature	Any PASPORT interface, 550, or 850	<ul style="list-style-type: none"> <li>Maximum sample rate 10 Hz</li> <li>General purpose for water/air from freezing to boiling</li> </ul>
PS-2143	Quad Temperature	Any PASPORT interface, 550, or 850	<ul style="list-style-type: none"> <li>Use for measuring up to four temperatures at once (different depths in water as it is cooled to freezing)</li> </ul>
<b>Temperature probes available for the above sensors CI-6605A, PS-2125, PS-2143:</b>			
PS-2135	Fast Response Temperature Probe		<ul style="list-style-type: none"> <li>Small mass changes temperature quickly</li> <li>For calorimetry</li> </ul>
PS-2131	Surface Temperature Probe		<ul style="list-style-type: none"> <li>Attaches to skin or surfaces</li> </ul>
PS-2153	Stainless Steel Probe		<ul style="list-style-type: none"> <li>Sturdy for mixing</li> <li>-35°C to +135°C</li> <li>More mass means it changes temperature more slowly</li> </ul>
PS-3201	Wireless Temperature	No interface required	<ul style="list-style-type: none"> <li>Bluetooth 4.0 required</li> <li>Does not have interchangeable probes</li> <li>General purpose for water/air from freezing to boiling</li> </ul>
PS-2197	Non-Contact Temperature	Any PASPORT interface, 550, or 850	<ul style="list-style-type: none"> <li>-70°C to 380°C</li> <li>Measure radiation from surfaces without touching</li> </ul>
PS-2134	Type K Temperature	Any PASPORT interface, 550, or 850	<ul style="list-style-type: none"> <li>-200°C to +1,000°C</li> <li>Measure temperature of liquid nitrogen and flames</li> </ul>

## Temperature

CI-6605A **ScienceWorkshop**

## ▶ Rugged sensor



PASCO's Stainless Steel Temperature Sensor offers a superior range, resolution and accuracy.

**Specifications****Temperature Range:** -35°C to +135°C**Accuracy:** ±0.5°C**Resolution:** 0.05°C**Pin Configuration:** 8-pin DIN plug**Order Information**

Temperature Sensor..... CI-6605A

## Temperature

PS-2125 **PASPORT**

PASCO's Stainless Steel Temperature Sensor offers a superior range, resolution and accuracy. It reports temperature (in °C, °F, or K) whether it is immersed in liquids, held in the air, or touching a solid surface.

**Typical Applications**

- ▶ Conduct general temperature experiments
- ▶ Measure rapid temperature changes found in endothermic-exothermic reactions
- ▶ Conduct environmental studies

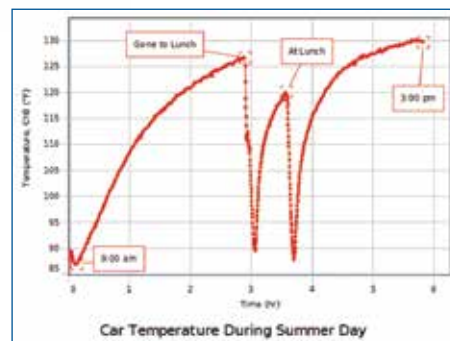
**Specifications****Range:** -35°C to +135°C**Accuracy:** ±0.5°C**Resolution:** 0.0025°C**Maximum Sample Rate:** 10 Hz**Displays:** °C, K and °F**Repeatability:** 0.1°C

Capstone graph showing the temperature inside a parked car on a summer day. We turned on the air conditioning when we drove to lunch.

**Order Information**

Temperature Sensor..... PS-2125

## Quad Temperature

PS-2143 **PASPORT\***



Connect up to four Temperature Probes for an experiment. Use with any combination of Stainless Steel, Fast Response or Skin/Surface Temperature probes for a wider variety of temperature measurements in the classroom or in the field.

### Typical Applications

- ▶ Thermal heat flow (one or two dimension)
- ▶ Comparative body temperatures
- ▶ Side-by-side chemical reactions
- ▶ Solar radiation
- ▶ Properties of insulation

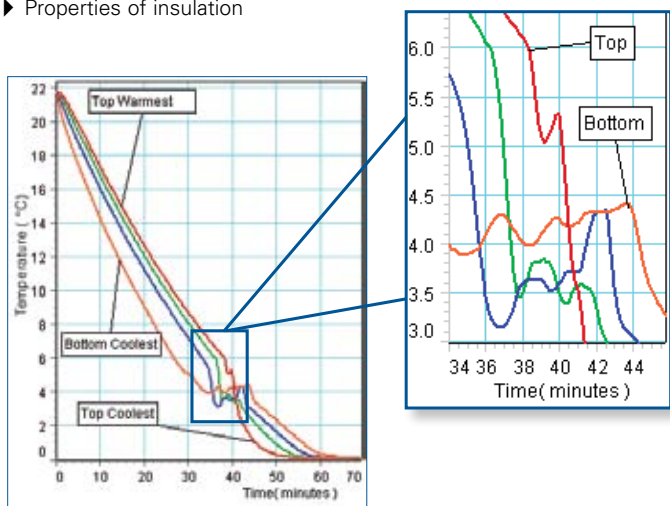

Four Fast Response Temperature Probes were used to study the temperature in a glass of water at four different levels as the water was cooled.

### Specifications

**Accuracy:** -35 to +135°C at ±0.5°C

**Displays:** °C, K and °F

**Resolution:** 0.0025°C

**Maximum Sample Rate:** 100 Hz

### Includes

- Two Stainless Steel Temperature Probes (PS-2153)
- Three Fast Response Probes

### Order Information

Quad Temperature Sensor .....PS-2143

## Temperature Probes

### Skin/Surface Temperature\*

PS-2131



- ▶ Flat sensing element ideal for surfaces
- ▶ Quickly reaches equilibrium temperature with surface

**Range:** -10 to +70°C



Make a temperature profile of the human hand.

### Order Information

Skin/Surface Temperature Probe\* .....PS-2131

### Fast Response Temperature Probe\* (3 pack)

PS-2135

- ▶ Accurately measures temperature changes in real time
- ▶ Ideal for small or hard-to-reach spaces
- ▶ Includes 10 Adhesive Patches
- ▶ Adhesive patches hold the Temperature Probe in place.



**Range:** -30 to +105°C

### Order Information

Fast Response Temperature Probe\* (3 pack).....PS-2135

### Stainless Steel Temperature Probe\*

PS-2153

**Range:** -35 to +135°C



### Order Information

Stainless Steel Temperature Probe\* .....PS-2153

\*All of the probes above require one of the following temperature sensors:

Temperature Sensor.....PS-2125 p. 44

Quad Temperature Sensor.....PS-2143 p. 45

Temperature.....CI-6605A

# Temperature

## Wireless Temperature Sensor

PS-3201



Welcome to the modern thermometer. Students can access instant temperature readings but also continuously monitor, log, and plot temperature data in SPARKvue on nearly any connected device. When class-time ends but the experiment continues, students can set the sensor to log data autonomously for days or weeks and then download the data for analysis.

### Typical Applications

- ▶ Simplicity: just pair and go, no cables and adapters to manage
- ▶ Variable sampling rate for capturing small fast changes or experiments that run for hours, days, or weeks
- ▶ Features convenient Bluetooth® wireless connectivity and long-lasting coin cell battery
- ▶ Logs temperature data directly onto the sensor for long-term experiments.



The versatile Wireless Temperature Sensor works well, both in the lab and outside.

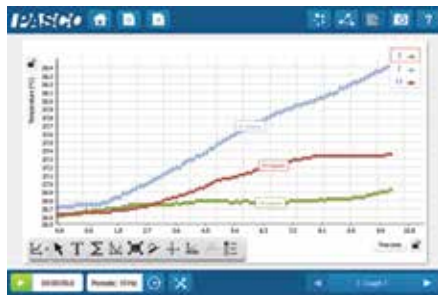

Easily compare the temperature in different environments. Works with SPARKvue and PASCO Capstone software.

### Specifications

**Range:** -40°C to 125°C

**Resolution:** 0.01°C

**Accuracy:** 0.5°C

**Displays:** °C, K, and °F

**Battery:** Coin cell included

**Logging:** Yes

**Bluetooth:** BT 4.0

### Order Information

Wireless Temperature Sensor..... PS-3201

*Recommended:*

Coin Cell Battery Pack (US only)... PS-3504

## Non-Contact Temperature

PS-2197 **PASPORT**

▶ Non-contact

▶ -70°C to 380°C



The Non-Contact Temperature Sensor measures surface temperature by detecting the emitted infrared light. Record the temperature of objects without touching them!

### Typical Applications

- ▶ Compare temperature of hands, skin, face and clothes
- ▶ Measure the temperature of different outdoor ground surfaces
- ▶ Map the temperature profile of an exterior wall

### Specifications

**Range:** -70°C to 380°C

**Accuracy:** ±0.5°C

**Response Time:** Less than 0.1 s

**Maximum Sample Rate:** 200 Hz

**Field of View:** ±35°

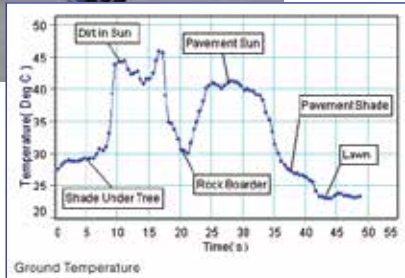

The student measures the late-morning ground temperature over four distinct surfaces. Starting in the shade under the distant tree, she then crosses bare dirt (in sun), a rock border, pavement, and lawn.

### Order Information

Non-Contact Temperature Sensor..... PS-2197

*Shown in use with:*

PASCO Capstone Software..... pp. 18-20

## Type K Temperature

PS-2134 **PASPORT**

▶ Extra-long probe



The PS-2134 is a single channel sensor that uses the same Type K thermocouple probe as the PS-2127 shown on this page. Includes one Type K Thermocouple.

### Typical Applications

- ▶ Measure temperatures down to -200°C
- ▶ Measure temperatures in hard-to-reach places
- ▶ Use in high temperature applications where the narrow tip of the probe can be applied without burning the insulation cover (such as a candle flame)

### Specifications

**Temperature Range:** -200°C to +1000°C

**Maximum Sample Rate:** 10 Hz

**Accuracy:** ±3°C or 3%, whichever is greater



The Type K Temperature Sensor can be used to measure the temperature of a flame. Works with any industry standard Type K thermocouple.

### Order Information

Type K Temperature Sensor ..... PS-2134

*Replacement Supply:*

Type K Thermocouple ..... PS-2155

## How to select the right Light Sensor for you

Part #	Sensor	Interface	Purpose
CI-6504A	Light	550/850 interfaces or legacy 500/750 interfaces	<ul style="list-style-type: none"> <li>Higher sample rates up to 10 MHz (depends on interface)</li> <li>Good for measuring the AC fluctuation of fluorescent and incandescent light bulbs</li> </ul>
CI-6604	High Sensitivity	550/850 interfaces or legacy 500/750 interfaces	<ul style="list-style-type: none"> <li>Higher sample rates up to 10 MHz (depends on interface)</li> <li>Good for diffraction and atomic spectra</li> </ul>
PS-3213	Wireless Light	No interface required	<ul style="list-style-type: none"> <li>Bluetooth 4.0 required</li> <li>Good for light level experiments and color detection</li> <li>Maximum sample rate 250 Hz</li> <li>Not suitable for diffraction or atomic spectra</li> </ul>
PS-2176	High Sensitivity	Any PASPORT interface, 550, or 850	<ul style="list-style-type: none"> <li>Great dynamic range</li> <li>Good for diffraction and atomic spectra</li> <li>Less noise at slower sample rate</li> </ul>
PS-2148	Infrared	Any PASPORT interface, 550, or 850	<ul style="list-style-type: none"> <li>For a lower price, use PS-3213 and get more functionality</li> </ul>
PS-2150	Broad Spectrum	Any PASPORT interface, 550, or 850	<ul style="list-style-type: none"> <li>300 to 10,000 nm range</li> <li>Required for the blackbody experiment</li> </ul>

### Light

CI-6504A

#### ScienceWorkshop



#### Typical Applications

- ▶ Compare light intensity vs. distance
- ▶ Study interference/diffraction/polarization
- ▶ Measure relative light intensities in daylight
- ▶ Monitor a solar eclipse

#### Specifications

**Sensing Element:** Si PIN photodiode

**Spectral Response:** 320 nm to 1100 nm

**Gain Levels:** 100x, 10x, 1x, switch-selectable

**Output Voltage:** 0 V to 5 V

**Pin Configuration:** 5-pin DIN plug on case

**Maximum Light Intensity Levels (lux):**

**Gain Setting:**            1x    10x    100x

**Approximate Lux:**        500    50        5

#### Order Information

Light Sensor ..... CI-6504A

### High Sensitivity Light

CI-6604

#### ScienceWorkshop



#### Typical Applications

- ▶ Spectrophotometry
- ▶ Interference and Diffraction patterns
- ▶ Measure light intensity vs. distance

#### Specifications

**Sensing Element:** Si PIN photodiode

**Spectral Response:** 320 nm to 1100 nm

**Gain Levels:** 100x, 10x, 1x, switch-selectable

**Output Voltage:** 0 V to 5 V

**Pin Configuration:** 8-pin DIN plug on case

**Maximum Light Intensity Levels (lux):**

**Gain Setting:**            1x    10x    100x

**Approximate Lux:**        5        0.5    0.05

#### Order Information

High Sensitivity Light Sensor ..... CI-6604

# Light

## Wireless Light

PS-3213

- ▶ Four sensors in one
- ▶ Ambient lux
- ▶ Ultraviolet and infrared
- ▶ Detect RGB colors separately
- ▶ Bluetooth 4.0 Wireless
- ▶ New enhanced features measure PAR and irradiant light!



Use the ultraviolet sensor on the back side to measure the amount of UVA and UVB radiation that makes it through sunglasses.



Ambient sensor contains lux, UV, IR sensors.

Spot sensor contains red, green, blue, and white sensors.

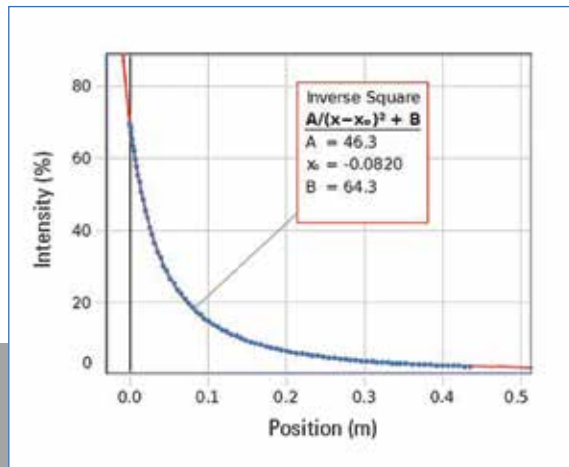

A quick way to show the Inverse Square Law of Light: Set a Wireless Light Sensor in a Wireless Smart Cart (ME-1241) and simply give the cart a push away from the Basic Optics Light Source (OS-8470). A plot of Light Intensity vs. Position recorded by the Smart Cart shows that the light drops off as one over the distance squared. The graph shown was made in PASCO Capstone.

### Specifications

- Light Level Range:** 0 to 131,000 lux
- Ultraviolet Range:** 300 nm to 400 nm (UVA and UVB)
- Infrared Range:** 700 nm to 1050 nm
- Maximum Sample Rate:** 2 Hz (ambient); 20 Hz (spot)
- Battery:** Coin Cell
- Bluetooth 4.0**
- Datalogging:** Yes

### Order Information

Wireless Light Sensor.....	PS-3213	
<i>Shown in use with:</i>		
Basic Optics Light Source.....	OS-8470	p. 256
Smart Cart (Blue) .....	ME-1241	p. 98
PASCO Capstone.....	pp. 18-20	

## High Sensitivity Light

PS-2176 **PASPORT**

- ▶ Ideal for low light experiments



The High Sensitivity Light Sensor is designed to perform visible light studies from low intensity spectral studies to daylight. Built-in automatic variable oversampling reduces noise.

### Typical Applications

- ▶ Spectrophotometry
- ▶ Interference and Diffraction patterns
- ▶ Measure light intensity vs. distance

### Specifications

**Sensing Element:** Si PIN photodiode

**Spectral Response:** 320 nm to 1100 nm

**Gain Levels:** 10,000x, 100x, 1x, switch selectable

**Approximate Lux Ranges:** 0 to 1, 0 to 100, 0 to 10,000

**Maximum Sample Rate:** 1000 Hz

**Resolution:**  $\pm 0.01$  Lux at 1000 Hz on 0 to 100 scale;  $\pm 0.0005$  Lux at 5 Hz on 0 to 100 scale

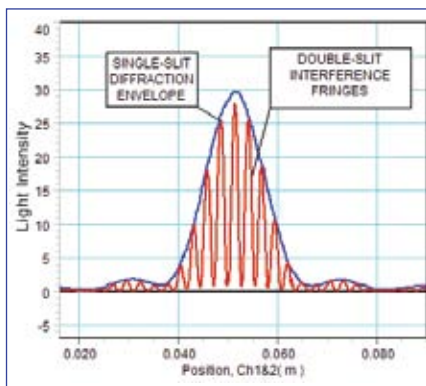

Computer scan of a single-slit and double-slit having the same slit width.

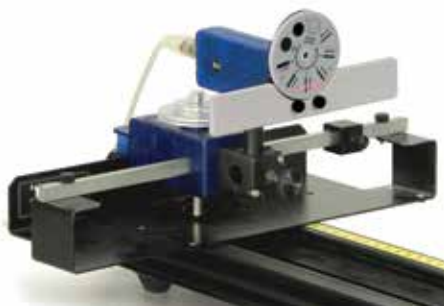

### Order Information

High Sensitivity  
Light Sensor ..... PS-2176

## Infrared Light

PS-2148

**PASPORT**



- ▶ For heat studies

The Infrared Sensor is sensitive in the infrared portion (up to 40,000 nm) of the spectrum, but also detects the visible spectrum. It can detect the radiation from a person's hand. The response is linear over its entire frequency range.

### Typical Applications

- ▶ Measure black body radiance
- ▶ Perform Leslie's Cube experiments
- ▶ Measure solar radiance
- ▶ Evaluate heat flow into or out of the sensor
- ▶ Simulate a non-contact temperature sensor

### Specifications

**Measure intensity** in Watts/Meter

**Maximum Sample Rate:** 100 Hz

**Spectral Response:** 580 to 40,000 nm

**Built-in thermistor** to measure temperature of the "cold" side of the thermopile in  $^{\circ}\text{C}$ ,  $^{\circ}\text{F}$  or K

### Order Information

Infrared Light Sensor ..... PS-2148

## Broad Spectrum Light

PS-2150 **PASPORT**

- ▶ For use with Spectrophotometer
- ▶ Ideal for Black Body Spectrum



The Broad Spectrum Light Sensor is designed specifically for use with our Educational Spectrophotometer System OS-8539 and Prism Spectrophotometer Accessory OS-8543 for Black Body experiments. The Broad Spectrum Light Sensor uses a thermopile and window combination that respond to both the near infrared and visible light necessary for the Black Body experiment.

### Typical Applications

- ▶ Black Body Experiment

### Specifications

**Sensing Element:** BaF<sub>2</sub> window, xenon gas-filled thermopile

**Spectral Response:** 300 to 10,000 nm

**Maximum Sample Rate:** 100 Hz

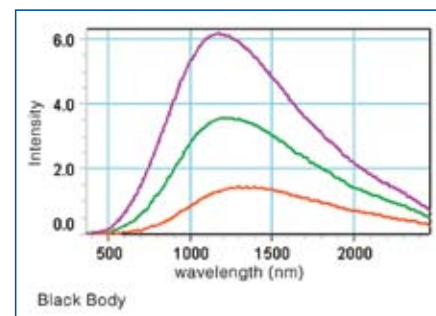

The classic textbook diagram of the intensity versus wavelength blackbody curves can be produced with real data. In this graph, the peak wavelength in the blackbody curve shifts as the source temperature is lowered. See page 290.



### Order Information

Broad Spectrum  
Light Sensor ..... PS-2150

## How to select the right Voltage and Current Sensor for you:

Part #	Sensor	Interface	Purpose
UI-5100/ UI-5110 CI-6556	Voltage Current	550/850 interfaces or legacy 500/750 interfaces	<ul style="list-style-type: none"> <li>Higher sample rates up to 10 MHz (depends on interface)</li> </ul>
UI-5100/ UI-5110 PS-2184	Voltage Current Probe	550/850 interfaces or legacy 500/750 interfaces	<ul style="list-style-type: none"> <li>Higher sample rates up to 10 MHz (depends on interface)</li> <li>Ideal for LRC circuits</li> </ul>
PS-3211 PS-3212	Wireless Voltage Wireless Current	No interface required	<ul style="list-style-type: none"> <li>Bluetooth 4.0 required</li> <li>Having a wireless current sensor ends confusion about the path of the current in the circuit.</li> </ul>
PS-2115	Voltage/Current	Any PASPORT interface, 550, or 850	<ul style="list-style-type: none"> <li>Gives voltage and current in one sensor. However, sample rate is limited to 1000 Hz so is not the best for high frequency circuits.</li> </ul>
PS-2193	High Current	Any PASPORT interface, 550, or 850	<ul style="list-style-type: none"> <li>Use when you need to measure high currents.</li> <li>Limited to 1000 Hz.</li> </ul>
PS-2160	Galvanometer	Any PASPORT interface, 550, or 850	<ul style="list-style-type: none"> <li>Use when you need to measure small currents or voltages.</li> <li>Limited to 1000 Hz.</li> </ul>

## For ScienceWorkshop 500 or 750 Interfaces:

### Voltage

UI-5100 **ScienceWorkshop**

UI-5110 (Shrouded) **ScienceWorkshop**

- ▶ For use with 500, 750, 850 and 550 interfaces
- ▶ Standard banana plugs and alligator clips



UI-5100

This voltage sensor plugs into any analog channel on a ScienceWorkshop Interface, the 850 Universal Interface, and the 550 Universal Interface. The voltage range and frequency response depend on the interface. When the voltage sensor is plugged into either the 550 or 850 Universal Interface, the sensor is automatically recognized.

#### Specifications

**Voltage Range:** ±20 V AC/DC (850 interface)  
±10 V AC/DC (other than 850)

**Pin Configuration:** 8-pin DIN plug  
Probe ends are standard banana plugs.  
Two alligator clip adapters included.



UI-5110 (Shrouded)

Similar to the UI-5100 shown at left, but has shrouded banana jacks and shrouded alligator clips.

#### Order Information

Voltage Sensor ..... UI-5100  
Voltage Sensor  
(Shrouded)..... UI-5110

### Current

CI-6556 **ScienceWorkshop**

- ▶ 1 Ω sensing resistor
- ▶ High sample rates



The Current Sensor determines the current through it by measuring the voltage across the internal 1.00 Ω resistor. Up to 1.5 A can be measured.

#### Specifications

**Maximum Current Input:** 1.5 A\*  
**Maximum Differential Voltage:** 1.5 V\*  
**Maximum Common Mode Voltage:** 10 V  
**Resolution:** 5 mA (1X gain), 0.5 mA  
\*DC or AC RMS (root mean square)

#### Order Information

Current Sensor ..... CI-6556

## For 550/850 Interfaces and for High Speed Sampling:

**Voltage Sensor** UI-5100/UI-5110

**Current Probe** PS-2184

When you're measuring voltage and current in AC circuits and need to sample fast, these sensors can sample as fast as 10 MHz on an 850 Universal Interface and up to 2 MHz on a 550 Universal Interface. The Voltage Sensors plug into the analog ports of these interfaces. The Current Probe is attached to the Voltage Sensor to measure the voltage drop across a precision 0.10  $\Omega$  resistor and outputs the resultant current calculation. Since the 850 Interface analog gain can be set to x1000, very small currents (0.024 mA resolution) can be read with the Current Probe.

The 850 Universal Interface can measure at a rate of 10 MHz on two channels simultaneously; 1 MHz on three or four channels simultaneously. The 550 Universal Interface has a maximum sample rate of 2 MHz on one channel; 1 MHz on two channels simultaneously.

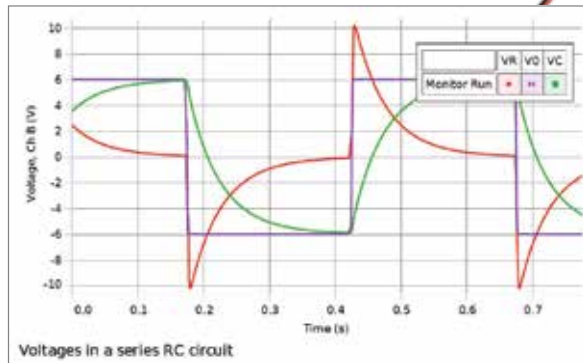

The high speed of the 850 Universal Interface, in scope mode, allows the examination of time varying voltages in an RC circuit to verify that Kirchhoff's loop theorem holds even when voltage is not constant.

### Voltage

UI-5100 **ScienceWorkshop**

UI-5110 (Shrouded) **ScienceWorkshop**

- ▶ For use with 500, 750, 850 and 550 interfaces
- ▶ Standard banana plugs and alligator clips



This voltage sensor plugs into any analog channel on a ScienceWorkshop Interface, the 850 Universal Interface, and the 550 Universal Interface. The voltage range and frequency response depend on the interface. When the voltage sensor is plugged into either the 550 or 850 Universal Interface, the sensor is automatically recognized.

#### Specifications

**Voltage Range:**  $\pm 20$  V AC/DC (850 interface)  
 $\pm 10$  V AC/DC (other than 850)

**Pin Configuration:** 8-pin DIN plug  
Probe ends are standard banana plugs.  
Two alligator clip adapters included.

See page 22 for the complete information about PASPORT and ScienceWorkshop sensors.



Similar to the UI-5100 shown at left, but has shrouded banana jacks and shrouded alligator clips.

#### Order Information

Voltage Sensor .....UI-5100  
Voltage Sensor  
(Shrouded).....UI-5110

### Current Probe

PS-2184

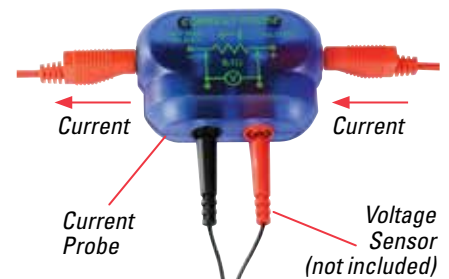

The PS-2184 attaches to any PASCO voltage sensor to allow the measurement of current between  $-4$  A and  $+4$  A. The probe contains a precision 0.10 ohm resistor and allows the precise measurement of the voltage drop across the resistor.

#### Specifications

**Resistor:** 0.10 Ohm, 3.0 W, 1.0%

**Maximum Current:** 4 A

**Maximum Voltage Without Damage:** 30 V

**Terminals:** 4 mm Banana Jacks

**Maximum Sample Rate:** Depends on interface

#### Order Information

Current Probe .....PS-2184

# Wireless Voltage/Current

## Wireless Current

PS-3212

This sensor's wide current range allows for introductory and advanced explorations of the fundamental concepts of electricity and basic circuits.

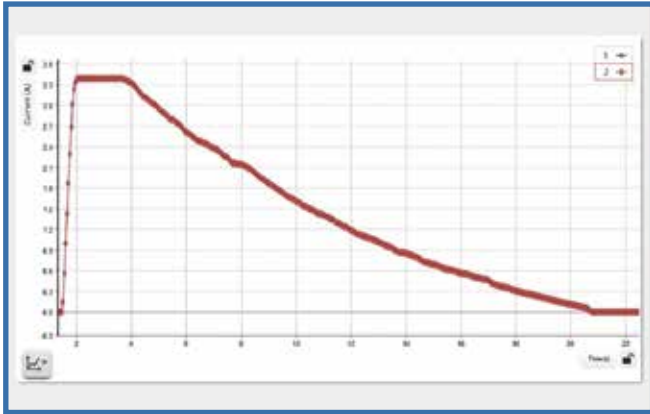

### Features

- ▶ **Two Ranges:**  $\pm 1A$ ,  $\pm 0.1A$
- ▶ **Resolution:** 0.2mA ( $\pm 1A$  range); 0.02mA ( $\pm 0.1A$  range)
- ▶ **Bluetooth® sampling rate of 1 kHz**
- ▶ **Higher speed sampling via USB**
- ▶ **Includes remote logging**

### Includes

- Rechargeable battery and USB cable
- 1 red and 1 black shrouded, banana-to-alligator-clip test leads

### Order Information

Wireless Current Sensor .....PS-3212

## Wireless Voltage

PS-3211



Explore energy and energy transformations with this sensor. Use it to:

- ▶ Measure the voltage of student-constructed batteries and see how chemical energy can turn into electrical energy.
- ▶ Look at renewable energy by connecting to a wind turbine.
- ▶ Track the flow of energy by creating simple circuits.

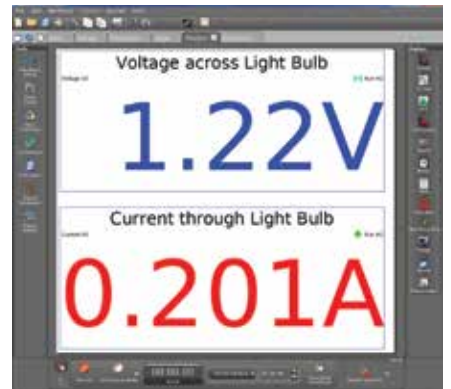
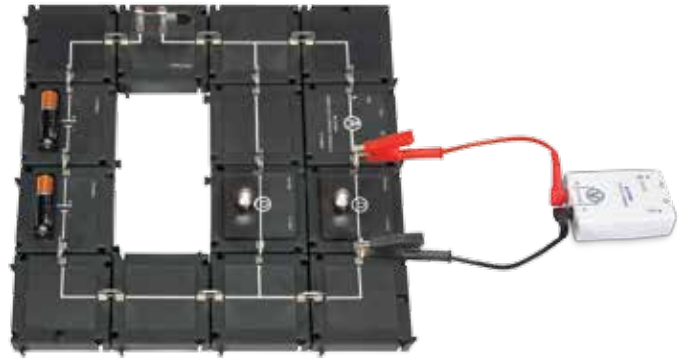

### Features

- ▶ **Two Ranges:**  $\pm 15V$ ,  $\pm 5V$
- ▶ **Resolution:** 7mV ( $\pm 15V$  range); 2mV ( $\pm 5V$  range)
- ▶ **Bluetooth® sampling rate of 1 kHz**
- ▶ **Higher speed sampling via USB**
- ▶ **Includes remote logging**

### Includes

- Rechargeable battery and USB cable
- 1 red and 1 black shrouded, banana-to-alligator-clip test leads

### Order Information

Wireless Voltage Sensor .....PS-3211

## Voltage/Current

PS-2115 **PASPORT**



The Voltage/Current Sensor combines both sensors in one case. This multi-measure probe uses only one connection so a single AirLink can be used. With overload protection, audible overload notification and automatic reset this sensor provides an ideal student measurement tool.

### Typical Applications

- ▶ Study circuit properties for both series and parallel electrical circuits
- ▶ Study the relationship of voltage and current in series-parallel circuits (Ohm's Law)
- ▶ Measure power used by an electrical device ( $P = I * V$ )
- ▶ Measure resistance of any circuit element ( $R = V / I$ )

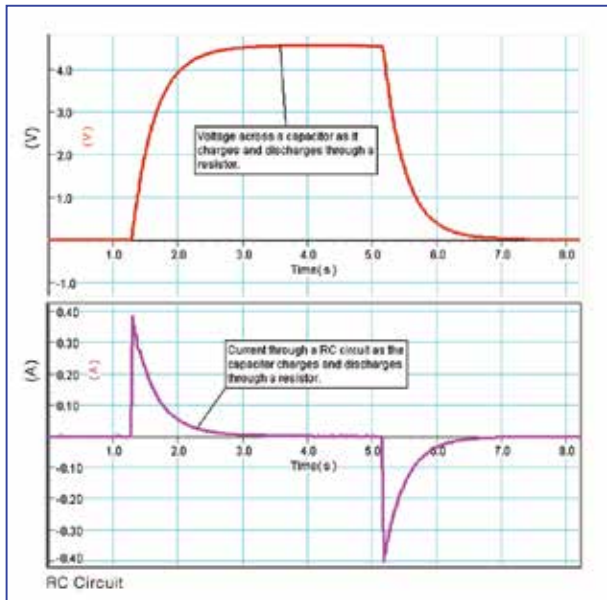

Capacitor voltage is shown as it is charged and discharged. The lower graph shows current through the series RC Circuit.

### Specifications

- Voltage Range:**  $\pm 10$  V, resolution of 0.005 volts
- Current Range:**  $\pm 1$  A, resolution of 0.5 mA
- Current Channel Series Resistance:** 0.6 ohms, < 0.9 ohms at room temperature
- Maximum Common Mode Voltage:** 10 V
- Maximum Sample Rate:** 1000 samples/sec
- Voltage Input Impedance:** 2 M $\Omega$

### Order Information

Voltage/Current Sensor .....PS-2115  
*Recommended:*  
 Alligator Clip Adapters (set of 10).....EM-8634

## High Current

PS-2193 **PASPORT**

- ▶ 10 Amp
- ▶ Over-current LED



The High Current Sensor has a low (0.01  $\Omega$ ) resistance sensing element, can measure up to 10 A, and has an LED over-current indicator. Dynamic variable over-sampling greatly reduces the measurement noise at low sample rates.

### Specifications

- Current Range:**  $\pm 10$  A, resolution of 0.5 mA
- Sensing Element Series Resistance:** 0.01  $\Omega$
- Maximum Common Mode Voltage:** 10 V
- Maximum Continuous Current Without Damage:** 12 A
- Maximum Continuous Overvoltage Without Damage:**  $\pm 40$  V
- Maximum Sample Rate:** 1000 samples/second

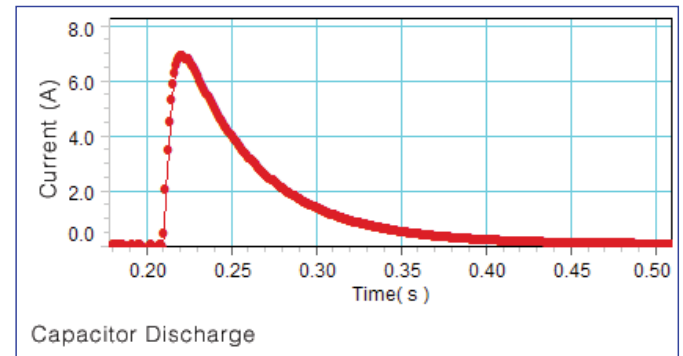

The capacitor is charged with a power supply to 10 volts, and then discharged through the Air Core Solenoid. The graph of the data shows the effect of the coils inductance on the rise time of the current.



### Order Information

High Current Sensor .....PS-2193  
*Shown in use with:*  
 Capacitor (0.025 F) 2 pack .....EM-8632 p. 217  
 Switch Set (SPST) 6 pack .....EM-8815 p. 218  
 Air Core Solenoid .....SE-7585 p. 226

# Galvanometer/Magnetic Field

## Galvanometer

PS-2160 **PASPORT**



The Galvanometer Sensor is designed to measure small voltages with high resolution. Dynamic variable over-sampling greatly reduces the measurement noise at low sampling rates. Shunt resistors are included to allow measurement of current.

### Specifications

**Voltage Range:**  $\pm 2000$  mV, resolution of 0.1 mV

#### Maximum Sample Rate:

5000 Hz with the 850 and 550  
1000 Hz with other interfaces

**Input Impedance:** 1 M $\Omega$

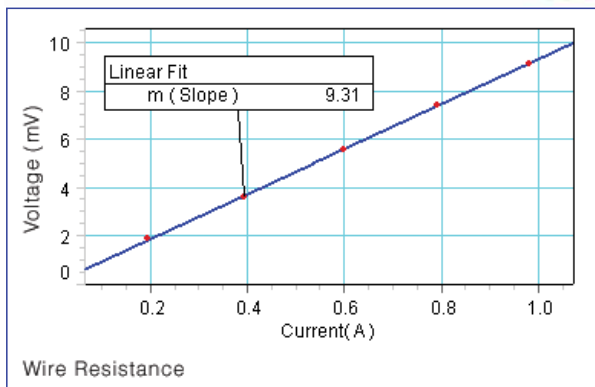

Galvanometer Sensor can measure the voltage drop across a short piece of wire.

A linear fit of voltage versus current yields the resistance of 0.0093  $\Omega$  for the wire.

By using a shunt resistor, the Galvanometer Sensor can be used to measure current.

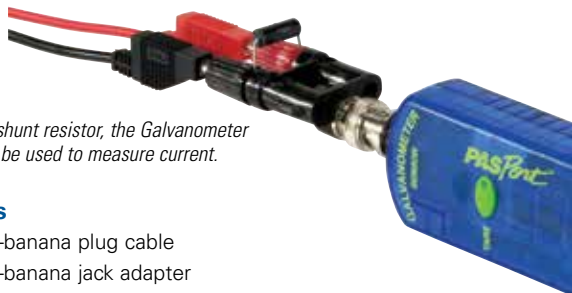

### Includes

- BNC-to-banana plug cable
- BNC-to-banana jack adapter
- 0.1  $\Omega$  and 10  $\Omega$  resistors

### Order Information

Galvanometer Sensor ..... PS-2160

#### Recommended:

Alligator Clip Leads (set of 10) ..... EM-8634

## Magnetic Field

PS-2112

**PASPORT**



The Magnetic Field Sensor provides magnetic field measurement in a compact package. The sensor at the tip of the probe measures magnetic field strength along the axis of the probe.

### Typical Applications

- ▶ Study the field strength of bar magnets and electromagnets
- ▶ Understand the field strength of a solenoid
- ▶ Measure the field strength of a Helmholtz coil

### Specifications

**Range:**  $\pm 1000$  gauss

**Accuracy:**  $\pm 3$  gauss or 5% of reading, whichever is greater @ 25°C (after four minute warm-up)

**Resolution:** 0.1 gauss (0.01% full-scale)

**Maximum Sample Rate:** 20 Hz

**Repeatability:** 0.05%

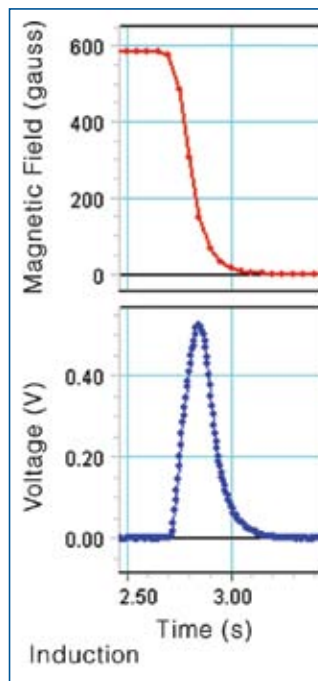

As the magnet is removed from the coil, a voltage is induced in the coil. The graph shows both the sudden decrease in magnetic field, as well as the voltage curve using a Voltage/Current Sensor.

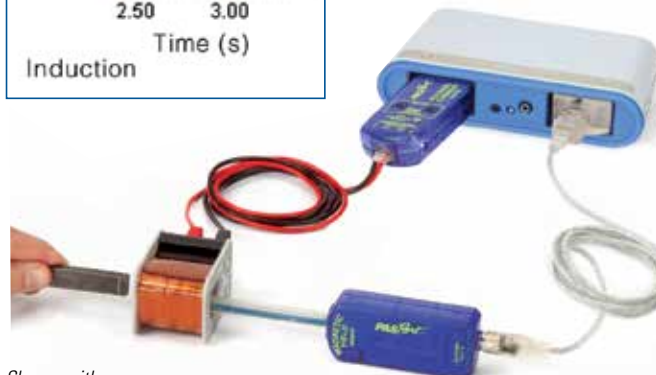

Shown with:

SPARKlink Air (PS-2011), Coil (3200 turn) (SF-8613), Bar Magnet (EM-8620), and Voltage/Current Sensor (PS-2115).

### Order Information

Magnetic Field Sensor (Digital) ..... PS-2112

## Magnetic Field

CI-6520A **ScienceWorkshop**



- ▶ Measures radial or axial fields
- ▶ High sample rate

PASCO's Magnetic Field Sensor is sensitive enough to detect Earth's magnetic field.

Its application in the physics lab includes measuring and plotting fields in single or Helmholtz coils, solenoids, electromagnets and magnets.

### Features

- ▶ **Measures radial or axial fields:** Two switch-selectable Hall Effect sensors measure either radial or axial fields.
- ▶ **Tare button:** Zeroing or nulling out existing fields is accomplished by pushing the Tare button.
- ▶ **Three switchable ranges of sensitivity:** Full scale ranges of 10, 100 and 1,000 gauss. Measurements from Earth's magnetic field to strong magnets.
- ▶ **7.5 cm probe:** Sensors are mounted at the end of a fully encapsulated 7.5 cm long probe.

### Specifications

#### Sensitivity:

- ± 10 gauss, 50 mG resolution;
- ± 100 gauss, 50 mG resolution;
- ± 1000 gauss, 500 mG resolution

**Measurement Modes:** Axial and Radial

**Probe Length:** 7.5 cm

**Pin Configuration:** 8-Pin DIN plug on case

### Order Information

Magnetic Field Sensor .....CI-6520A

*Recommended:*  
Zero Gauss Chamber.....EM-8652

## Zero Gauss Chamber

EM-8652



This double-walled, high permeability metal chamber produces a zero gauss field within the chamber. By placing the Magnetic Field Sensor probe into the chamber and pushing the "Tare" button, the sensor may be zeroed. Highly recommended for measurement of Earth's magnetic field.

### Order Information

Zero Gauss Chamber.....EM-8652

## 2-Axis Magnetic Field

PS-2162

**PASPORT**



- ▶ Measures radial and axial fields
- ▶ Tare button

Measure Radial and Axial Fields simultaneously. Dynamic variable over-sampling greatly reduces noise at low sample rates.

### Typical Applications

- ▶ Measure Earth's magnetic field.
- ▶ Measure magnetic field (magnitude and direction from a coil or a bar magnet).

### Specifications

**Range:** ±1000 gauss

**Accuracy:** 5% of reading @ 25°C (after four minute warm-up and Tare using Zero Gauss Chamber)

**Resolution:** 0.01 gauss @ 10 Hz

**Maximum Sample Rate:** 1000 Hz

**Repeatability:** 0.05%

### Includes

- Sensor handle
- Sensor extension cable

*Shown with: Rotary Motion Sensor (PS-2120), Linear Motion Accessory (CI-6688A), Field Coil (EM-6711).*

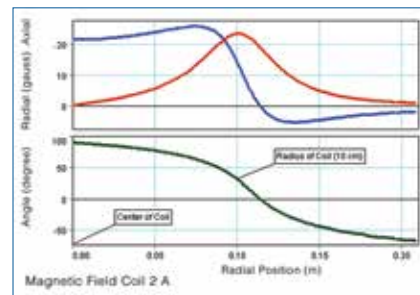

*Magnetic field is measured from the center out to twice the radius of the coil. The angle of the resultant field is calculated.*

### Order Information

2-Axis Magnetic Field Sensor .....PS-2162

*Recommended:*  
Zero Gauss Chamber.....EM-8652  
Linear Accessory Kit.....CI-6688A

p. 25

# Charge and General Science

## Charge

PS-2132 **PASPORT**

- ▶ Ideal for electrostatics



The Charge Sensor is designed for experiments in electrostatics such as inductive charging, charge production/distribution, and charge on a capacitor. The sensor features automatic scaling, eliminating the need for a gain switch. Designed with highly efficient input over-voltage protection, the Charge Sensor is virtually "blow-out" proof and will provide many years of use in the student lab.

When used with the Faraday Ice Pail, the Charge Sensor can measure the total charge on an object by the induction method.

The Charge Sensor can also be used as a high impedance voltmeter ( $10^{12} \Omega$ ). It includes a 0.9 m shielded cable with alligator clips to eliminate stray fields.

### Typical Applications

- ▶ Measure charge by induction
- ▶ Quantify the charge on a capacitor plate
- ▶ Discover the charge distribution on a conducting sphere

See pages 214-215 for additional applications.

### Specifications

**Charge Range:**  $\pm 0.1 \mu\text{C}$

**Voltage Range:**  $\pm 10 \text{ V}$

**Input Resistance:**  $10^{12} \Omega$

**Maximum Input Voltage:** 150 V

**Maximum Sample Rate:** 100 Hz

**Input Connector:** BNC

**Input Cable:** 0.9 m length; shielded with alligator termination



The Charge Sensor measures equal yet opposite charge on two objects.

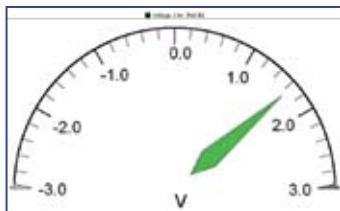

### Order Information

Charge Sensor..... PS-2132

Recommended:

Faraday Ice Pail ..... ES-9042A p. 207

## Basic Electrometer

ES-9078A

- ▶ For 550/850 and ScienceWorkshop Interfaces

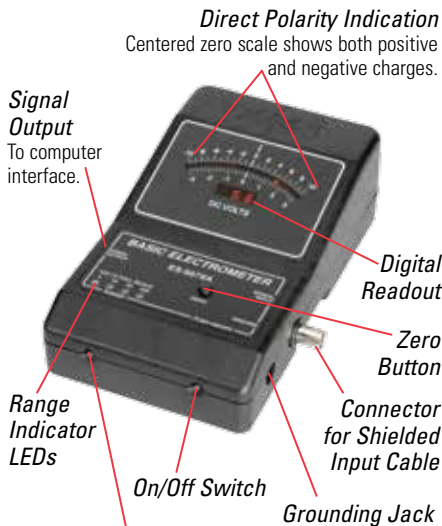

**Range Adjustment Switch**  
Adjust the sensitivity to match the experiment.

The PASCO Basic Electrometer is a quantitative electroscopes, measuring the polarity and magnitude of charged objects. With almost infinite input resistance ( $10^{14} \text{ ohm}$ ), the Electrometer is a high-impedance voltmeter, draining almost no charge from the object it is measuring.

### Features

- ▶ **Center-Zero Meter:** Polarity is indicated directly.
- ▶ **3, 10, 30, and 100 VDC Switch-Selectable Ranges:** LED lamps indicate the range in use.
- ▶ **Zeroing Switch:** For removing all charge from the input and bringing the meter to zero.
- ▶ **Automatic Shutoff:** Unit turns off about three hours after being used.
- ▶ **Output compatible with the 850 Universal Interface and ScienceWorkshop Interfaces:** For recording data or producing a demonstration-sized meter display.
- ▶ **Battery Operation:** Uses four "AA" cells (included). Range indicator lights flash when batteries need to be replaced.

### Includes

- Shielded input cable to connect the Electrometer to the Faraday Ice Pail or other source of charge
- Grounding cable with clip
- Interface cable
- Instruction and experiment manual

### Order Information

Basic Electrometer..... ES-9078A

## General Science Sensor

PS-2168 **PASPORT**

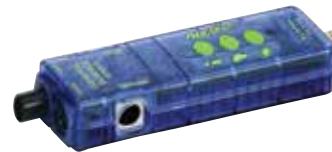

Simultaneously measure temperature, light, sound level, and voltage. Great for a variety of general science explorations.

### Specifications

**Temperature\*:**  $-35^{\circ}\text{C}$  to  $+135^{\circ}\text{C}$ ;  $\pm 0.5^{\circ}\text{C}$

\*Range is probe dependent.

**Light:** 3 user selectable light ranges:

- 0 to 100; 0 to 10,000;
- 0 to 150,000 Lux

**Sound Level:** 50 to 100 dbA

**Voltage:**  $\pm 24 \text{ V}$

**Voltage Protection:** up to 240 V

**Maximum Sample Rate:** 200 Hz

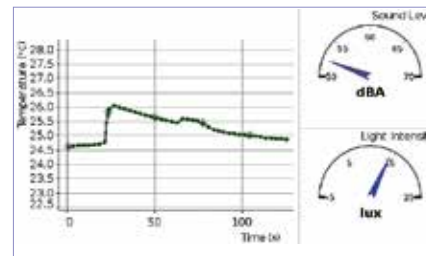

Sensor has three selectable ranges for low, indoor, and outdoor measurements.

### Includes

- Stainless Steel Temperature Probe
- Voltage Probe

### Order Information

General Science Sensor .....PS-2168

Recommended:

Charge/Discharge

Circuit.....EM-8678A p. 210

## Sound Level

PS-2109  
**PASPORT**



The Sound Level Sensor is designed to measure the intensity level of sound sources within proximity to the sensor. The sensor features three range switches to match the intensity range of the measured phenomena.

The sensor measures sound level in both the dBA and dBC scales. The dBC scale includes all frequencies incident on the Sound Level Sensor, whereas the dBA scale filters out some frequencies to more closely match the frequency response of the human ear.

The sensor also reports a measurement of sound intensity in  $\mu\text{W}/\text{m}^2$ , which is calculated from the dBC measurement of the sound level.

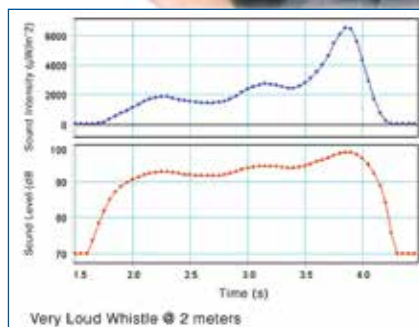

Graph shows sound level from a loud whistle in both intensity ( $\mu\text{Watts}/\text{m}^2$ ) and in decibels. Notice the difference in scales.

### Typical Applications

- ▶ Explore sound levels outside the classroom
- ▶ Discover the logarithmic relationship between sound level and sound intensity

### Specifications

**Range:** Sound Level Intensity  
30 dB to 70 dB;  $10^{-3} \mu\text{W}/\text{m}^2$  to  $10 \mu\text{W}/\text{m}^2$   
50 dB to 90 dB;  $1 \mu\text{W}/\text{m}^2$  to  $1000 \mu\text{W}/\text{m}^2$   
70 dB to 110 dB;  $10 \mu\text{W}/\text{m}^2$  to  $10,000 \mu\text{W}/\text{m}^2$

**Max Sample Rate:** 20 Hz  
**Accuracy:**  $\pm 2$  dB at 94 dB (1000 Hz)  
**Resolution:** 0.1 dB

### Order Information

Sound Level Sensor..... PS-2109

## Sound

CI-6506B  
**ScienceWorkshop**



- ▶ Measures sound waveform

The Sound Sensor houses a sensitive microphone designed to display audio waveforms of sound levels between 45 and 100 dB.

### Typical Applications

- ▶ Measure basic sound intensity
- ▶ Measure speed of sound measurement
- ▶ Measure beats
- ▶ Study the doppler effect
- ▶ Conduct voice studies
- ▶ Learn musical instrument overtones

### Specifications

**Frequency Response:** 20 to 7,200 Hz  
**Decibel Range:** 45 to  $>100$  dB  
**Signal-to-Noise Ratio:**  $< 60$  dB  
**Amplification:** Two stages condition low-level signals  
**Pin Configuration:** 8-pin DIN plug on case

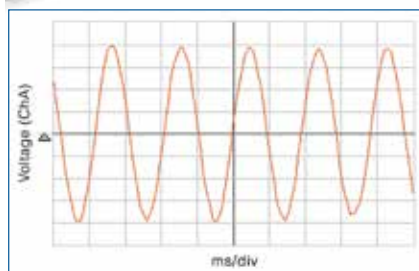

This oscilloscope display shows the sinusoidal nature of a "middle C" tuning fork (261 Hz).

### Order Information

Sound Sensor..... CI-6506B

## Temperature/Sound Level/Light

PS-2140  
**PASPORT**



Launch students into an instant exploration of their environment! The Temperature/Sound Level/Light Sensor allows students to conduct all three measurements simultaneously and continuously. Add an optional Stainless Steel Temperature Probe (PS-2153) to conduct water studies.

### Typical Applications

- ▶ Measure the temperature difference between the floor and ceiling
- ▶ Determine the light level on a sunny versus cloudy day
- ▶ Compare sound levels of students whispering, singing loudly or applauding

### Specifications

**Temperature (internal) Range:**  $-10$  to  $+50^\circ\text{C}$   
**Sound Level Range:** 40 to 90 dBA  
**Light Range:** 0 to 5000 lux  
**Maximum Sample Rate:** 5 Hz

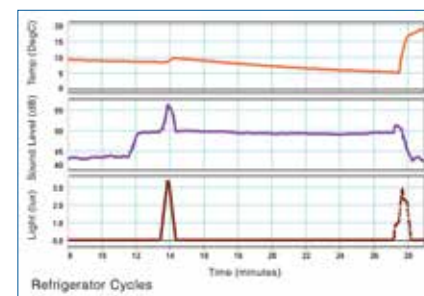

The temperature, light intensity, and sound level are simultaneously measured inside a refrigerator. Note the changes in measurements as the compressor starts and as the door is opened.

### Order Information

Temperature/Sound Level/Light Sensor ..... PS-2140  
**Recommended:**  
Stainless Steel Temperature Probe..... PS-2153

## Heater-Stirrer

NEW



PS-3401



### The Heater-Stirrer is the new lab essential!

This compact heater-stirrer has a white ceramic top that is ideal for heating and for seeing color changes when mixing solutions. It has been designed to withstand spills. Its safety features include warning labels and indicator LEDs. And the included rod makes it easy to support sensors.

#### When used as a heater:

This compact new Heater-Stirrer can boil water in minutes. The ceramic top provides an even heating surface and the indicator LEDs let you know when the top is hot.

#### When used as a stirrer:

This new apparatus is great for mixing solutions. The white top makes color changes during titrations easy to see.



#### Specifications

**Speed range:** 50-1500 rpm

**Plate diameter:** 135 mm

**Max temperature:** 310°C

#### Includes

- Support rod.

#### Order Information

Heater-Stirrer ..... PS-3401

## High Accuracy Drop Counter

PS-2117 **PASPORT**

At last, a professional Drop Counter can become part of your student lab. Our Drop Counter has a wider (18 x 13 mm) drop window for better drop detection and easier alignment with burettes. Works equally well with large or small, fast or slow drops. Easy calibration requires entering just one number into the computer. Includes a Micro Stir Bar for use with our pH and Conductivity Probes (see previous page).



- ▶ Measures up to 40 drops per second with drops as small as 0.64 mm.
- ▶ Silicone rubber-sealed polypropylene is fluid resistant and protects sensor from mild acids and bases.
- ▶ Automatically recalibrates for maximum sensitivity each time the unit is turned on.

#### Typical Applications

- ▶ Determine the equivalence point
- ▶ Simple count activities

#### Specifications

**Measures up to 40 drops** per second with drops as small as 0.5 mm.

**Silicone rubber-sealed polypropylene** is fluid resistant and protects sensor from mild acids and bases.

**Automatically recalibrates** for maximum sensitivity each time the unit is turned on.

**Holds up to three probes** in a 150 mL beaker.

#### LED drop indicator

**IR filter** rejects all visible light – not susceptible to variations in room lighting.

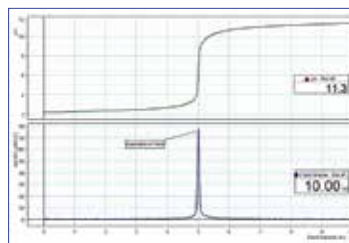

#### Order Information

High Accuracy Drop Counter ..... PS-2117

## Micro Stir Bar

PS-2565

The Micro Stir Bar maintains a constant flow of solution over the end of the electrode, such as in the pH and conductivity probes. For use with a standard stir plate and cylindrical probes of about 13 mm diameter.

*Magnet is completely sealed to prevent damage from the chemicals.*



#### Order Information

Micro Stir Bar (set of 5) ..... PS-2565

## Wireless pH Sensor

PS-3204



Here's the best tool for measuring pH since litmus paper. Students can quickly obtain accurate pH readings but also log data to their connected device and even program the sensor to collect data autonomously for hours or weeks. Use the sensor to study water quality, environmental monitoring, testing solutions, and chemical reactions.



*With the Wireless pH Sensor, students can collect data anywhere!*

*Easily measure and compare the pH of common acids and bases.*



### Teaching Advantage

- ▶ Simplicity: just pair and go, no cables and adapters to manage
- ▶ Compatible with ion-selective electrodes (ISE) and oxidation reduction probe (ORP)
- ▶ Features convenient Bluetooth® wireless connectivity and long-lasting coin cell battery.
- ▶ Logs pH data directly onto the sensor for long-term experiments.

### Includes

- 1 coin cell battery and a direct-connect pH probe with storage bottle.

### Specifications

**Range:** 0-14 pH  
**Resolution:** 0.02 pH  
**Accuracy:** +0.1 pH  
**Battery:** Coin cell included  
**Logging:** Yes  
**Bluetooth:** BT 4.0

### Order Information

Wireless pH Sensor..... PS-3204  
*Recommended:*  
 Coin Cell Battery Pack

## Flat pH Probe

PS-3514



This pH probe gives you the freedom to measure what you want, where you want. Study pH levels in different kinds of foods, investigate the pH of common skin and hair care products, and easily collect pH data when doing soil analysis.



*Connects to and requires a Wireless pH Sensor.*

### Includes

- Soaker bottle

### Order Information

Flat pH Probe ..... PS-3514  
*Requires:*  
 Wireless pH Sensor..... PS-3204

Get even more measurements out of the Wireless pH Sensor by using these ORP or ISE electrodes.

## Oxidation Reduction Potential Probe

PS-3515



## Probes and Electrodes



### Includes

- Cable

### Order Information

Oxidation Reduction Potential Probe..... PS-3515  
 Ion Selective Electrodes  
 Ammonium ..... PS-3516  
 Carbon Dioxide ..... PS-3517  
 Calcium ..... PS-3518  
 Chloride ..... PS-3519  
 Potassium ..... PS-3520  
 Nitrate ..... PS-3521

# Chemistry

## Wireless Colorimeter and Turbidity

PS-3215



The Wireless Colorimeter simultaneously measures the absorbance and transmittance of six different wavelengths. The sensor can be used to study enzyme activity, photosynthesis, and the rates of chemical reactions. By using the accessory cuvettes and a calibration standard, the colorimeter also functions as a turbidimeter for water quality analysis.

### Specifications

**Color detection/peak wavelengths detected:** 650 nm (red), 600 nm (orange), 570 nm (yellow), 550 nm (green), 500 nm (blue), 450 nm (violet)

**Detector ranges:** +25 nm from peak

**Absorbance:** 0-3 Abs units; useful range (0.05 -1.5 Abs)

**Transmittance:** 0-100%

**Turbidity range:** 0-400 NTU

**Accuracy:** +5% NTU

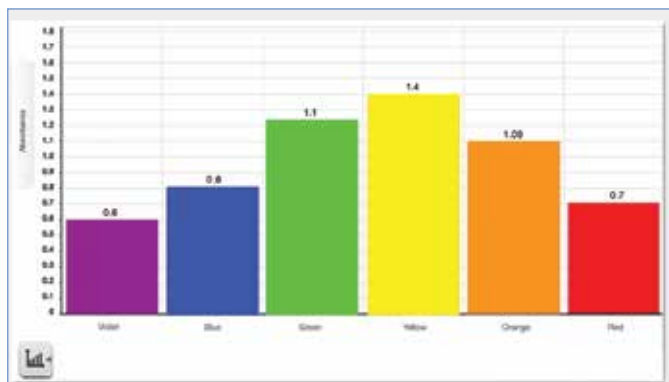

Measure the absorbance and transmittance of a solution at six different wavelengths... simultaneously!

### Includes

- USB charging cable
- Cuvettes (9)
- Cuvette racks (2)
- 100 NTU calibration cuvette (1)

### Order Information

Wireless Colorimeter and Turbidity.....PS-3215

## Cuvette Rack

SE-8777

A small rack that is used to hold the 3.5 mL cuvettes used with the PASCO Wireless Spectrometer and Wireless Colorimeter and Turbidity. Avoid spills and messes and help organize activities using multiple samples.



The cuvette holder is made of white plastic, holds 12 cuvettes, and the cuvette slots are shallow enough to allow users to see the color of the sample in the cuvette.

### Order Information

Cuvette Rack.....SE-8777

## G-M Tube/Power Supply

SN-7927A

- ▶ Ideal general purpose nuclear sensor



The G-M Tube/Power Supply senses alpha, beta and gamma radiation. Power for the tube is supplied through the connection to an interface that supplies an operating voltage of +5 V.

### Specifications

**Sensitivity:** Beta, Gamma, Alpha

**Count Detection:** Audio signal

**Window Thickness:** 1.5 to 2 mg/cm<sup>2</sup>, mica

**Gas Filling:** Neon, Argon and Halogen

**Starting/Operating Voltage for tube:**

450 VDC/500 VDC

**Dead Time:** 90 μs

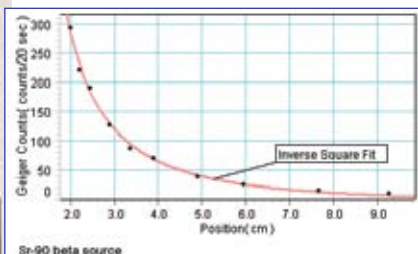

The number of counts per time interval drops off as the distance between the detector and the radioactive source is increased.

The G-M Sensor can be attached directly to the rack on a Rotary Motion Sensor to measure (real-time) the count rate as a function of distance from the source.

### Order Information

G-M Tube/Power Supply ..... SN-7927A

**Required for use with SPARKlink Air or AirLink:**

Digital Adapter ..... PS-2159 p. 39

## Polarimeter

PS-2235

- ▶ For Chromebook™, iPad® and computers
- ▶ Measure the optical rotation of chiral compounds.



PASCO's Polarimeter has both Bluetooth® and USB connectivity, so it works on your iPad®, Chromebook™, and computers. It is ideal for introductory Organic and Biochemistry experiments with chiral compounds. Plane polarized light is passed through a sample which contains a chiral compound, to an analyzer and a detector. The degree of optical rotation of the plane polarized light is based on the type and amount of sample present. Determine the concentration of a sugar solution based on the optical rotation of plane polarized light.

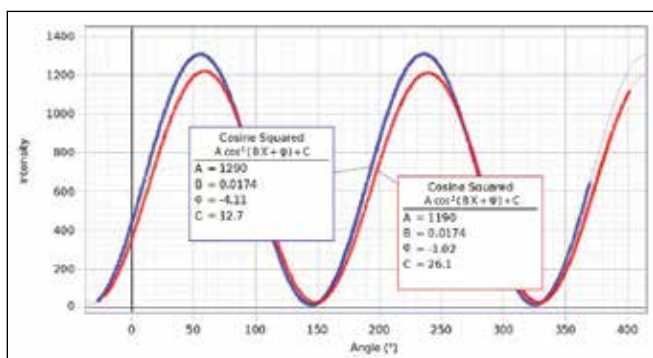

Determine the concentration of a sugar solution based on the optical rotation of plane polarized light.

### Specifications

**Bluetooth® and USB** connectivity

**589 nm LED** light source

**Accuracy = ± 0.09°** optical rotation

**SPARKvue- and Capstone-compatible**

**Industry-standard**, horizontal polarimeter sample cell (100 mm)



### Includes

- Polarimeter
- One Sample Cell

### Order Information

Polarimeter (Bluetooth) ..... PS-2235

**Also available:**

Polarimeter Sample Cell Replacement ..... PS-2234

## Polarimetry Demonstration

Introduce the concept of polarimetry with this colorful demonstration. Fill one jar with water and the other with a sugar solution. Rotate the front polarizer to show the optical rotation.

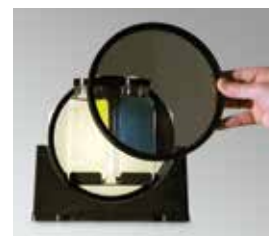

White light source not included. See page 261 for more details.

### Order Information

Polarimetry Demonstration

**Required:**

Polarizer Demonstrator ..... OS-9477A

Polarization Demonstrator Accessory ..... OS-8172

## Chemistry

Award-Winning  
Wireless Spectrometer

PS-2600

- ▶ For iPad®, Android™ tablets, Chromebooks\* and computers
- ▶ Measure intensity, absorbance, transmittance, and fluorescence

\*Our list of compatible Chromebooks is rapidly expanding.

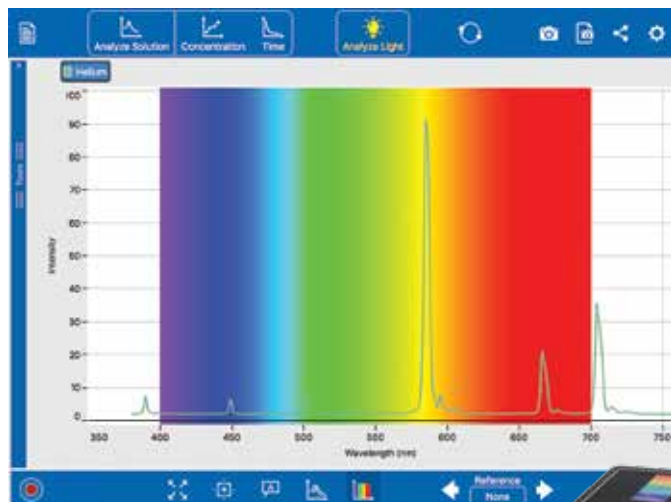
//CODiE//  
2017 SIIA CODIE WINNER

Emission spectrum of helium

## Perform these labs with the PASCO Spectrometer:

- ▶ Light intensity across the visible spectrum
- ▶ Emission spectra of light sources
- ▶ Match known spectra with references

## Specifications

**Connectivity:** Bluetooth and USB connectivity**Resolution:** 2–3 nm FWHM**Range:** 380–950 nm**Optical resolution:** 2 fluorescence excitation wavelengths at 405 nm and 500 nm**Light source:** LED-boosted tungsten

## Includes

- PASCO Spectrometer
- Spectrometry software
- 10 cuvettes



The PASCO Spectrometer comes with PASCO's FREE award-winning spectrometry software.

- ▶ Windows® and Mac® versions included with purchase.
- ▶ FREE app for iOS, Android, and Chrome\*
- ▶ Designed specifically for introductory spectrometry experiments.

\*See our ever-growing list of supported Chromebooks at [pasco.com/spectrometry](http://pasco.com/spectrometry)

## Order Information

Wireless Spectrometer (Bluetooth).....PS-2600

Required for External Light Sources:

Fiber Optics Cable.....PS-2601 p. 272

## Wireless CO<sub>2</sub> Sensor



PS-3208

Use this wireless sensor to measure the concentration of CO<sub>2</sub> gas in a closed system or open environment. Study core topics (including photosynthesis, respiration and carbon cycling) with this versatile probe. CO<sub>2</sub> data can be logged directly on the device for long-term life science and environmental science studies.



Directly compare separate controlled environments.

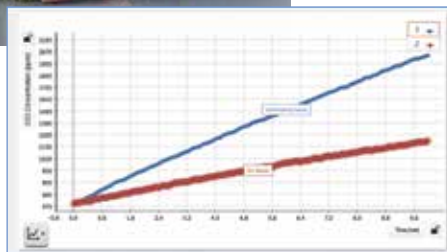

### Specifications

**Range:** 0 to 100,000 ppm

**Resolution:** 2 ppm

**Connection:** Bluetooth® 4.0 or USB

**Battery life:** ≥18 hours of continuous use

**Accuracy:** 0 to 1k: ±100ppm

1 to 10k: ±5% of reading ±100 ppm

10k to 50k: ±10% of reading

50k to 100k: ±15% of reading

**Warm-up time:** 3 min

**Response time:** 90% in 30 sec

(See [pasco.com](http://pasco.com) for the latest specs.)

### Includes

- 250-ml sampling bottle
- USB charging cable

### Order Information

Wireless CO<sub>2</sub> Sensor.....PS-3208

## Dissolved CO<sub>2</sub> Waterproof Sleeve

PS-3545

The Wireless CO<sub>2</sub> Sensor can be equipped for aqueous measurements using this semipermeable sleeve. The sleeve is waterproof but allows CO<sub>2</sub> gas to pass through the membrane, creating a headspace around the sensor. Monitor photosynthesis and respiration of aquatic plants or animals with the sample bottle or with other chambers. (Please note: Improper use will void sensor warranty.)

### Includes

- Sleeves (5)
- O-rings (5)



### Order Information

Dissolved CO<sub>2</sub>  
Waterproof Sleeve.....PS-3545

## O<sub>2</sub> Gas

PS-2126A

PASPORT



PASCO's Oxygen Gas Sensor accurately measures oxygen concentration in the atmosphere or in enclosed spaces, such as terrariums. The sensor's wide range (0-100%) means students can use it with any experiment or investigation. Use in combination with the CO<sub>2</sub> Gas Sensor to perform an even wider variety of environmental and physiology activities in the classroom or in the field.

### Specifications

**Flow Range:** 0 to 100% oxygen concentration

**Accuracy:** ±1% (at constant temperature)

**Resolution:** 0.025%

**Maximum Sample Rate:** 100 Hz

**Probe Shelf-life:** Three years

### Typical Applications

- ▶ Measure the respiration of animals, insects or germinating seeds
- ▶ Study the catalase breakdown of hydrogen peroxide
- ▶ Monitor O<sub>2</sub> level changes during photosynthesis in a terrarium
- ▶ Study cellular respiration of yeast

### Special Features

- ▶ Single point calibration requires just the touch of a button
- ▶ Automatic temperature compensation ensures consistent measurements
- ▶ Usable in any orientation

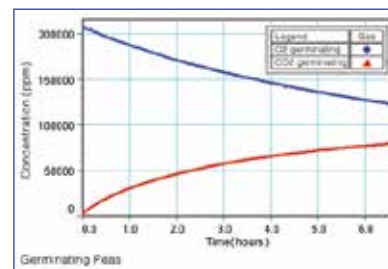

O<sub>2</sub> and CO<sub>2</sub> Concentration (ppm) vs. Time (hours)

### Order Information

O<sub>2</sub> Sensor .....PS-2126A

# Biology

## Ethanol Sensor

PS-2194  
PASPORT



The PASPORT Ethanol Sensor measures the concentration of gaseous ethanol up to 3%. In biology and environmental science labs, students can learn about anaerobic respiration by measuring the production of ethanol by bacterial or yeast fermentation. Physics and chemistry students can begin to explore combustion and thermodynamics. Connect your students to the study of respiration and alternative energy sources with the PASPORT Ethanol Sensor.

### Specifications

**Accuracy:** 20% of reading  
**Range:** 0% to 3% gaseous ethanol



*Students can vary environmental conditions such as temperature and determine the impact on the rate and type of cellular respiration taking place. In this example, as the temperature increases, the rate of ethanol production is also increasing.*

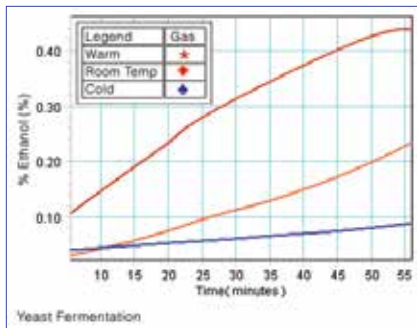

### Order Information

Ethanol Sensor ..... PS-2194  
*Shown in use with:*  
EcoChamber..... ME-6667  
Magnetic Stirrer..... SE-7700

## Optical Dissolved Oxygen

PS-2196 PASPORT



The PASCO Optical Dissolved Oxygen Sensor makes it easier than ever before to measure dissolved oxygen in the field or lab environment. The luminescent technology has several advantages over galvanic DO sensors including:

- ▶ No flow dependency – no stirring required
- ▶ No warm-up time
- ▶ No calibration required
- ▶ Low maintenance – no filling solution and electrode polishing
- ▶ Built-in temperature and pressure compensation
- ▶ Ability to measure gaseous as well as dissolved oxygen

### Specifications

**Cable Length:** 3 m  
**Response Time:** 90% in 25 sec  
**Operating Temperature:** 0–50°C  
**Operating Pressure:** 375–825 mmHg  
**Range:** 0–20 mg/L or 0–300% saturation  
**Accuracy:**  
±0.6 mg/L or ±3.0% out of box  
±0.1 mg/L or ±1.0%, whichever is greater after calibration  
Above 200% ± 10%

### Order Information

Optical Dissolved Oxygen Sensor..... PS-2196  
**Recommended:**  
Optical Dissolved Oxygen Sensor Replacement Cap..... PS-2587

## Optical Dissolved Oxygen Sensor Metal Guard

PS-2588



### Includes

- Stainless steel sleeve

### Order Information

Optical Dissolved Oxygen Sensor Metal Guard..... PS-2588

## Photosynthesis Tank

PS-2521B

- ▶ Measure O<sub>2</sub> production directly
- ▶ Control the environment of the aquatic plant
- ▶ Study changes in photosynthesis/respiration rates

Typical experiments involving photosynthesis require students to infer photosynthetic rate changes by using chloroplasts and dye. Help students understand this concept more completely by directly measuring the production of oxygen.

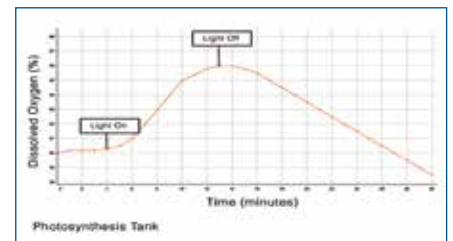

*Water in the outer tank is used to control large fluctuations in temperature when the light is used. Students can further their understanding of photosynthetic rates by adding dyes as colored filters.*

### Includes

- Acrylic chamber
- Rubber stoppers



### Order Information

Photosynthesis Tank..... PS-2521B  
*Shown in use with:*  
Optical Dissolved Oxygen Sensor ..... PS-2196

## Aquatic Productivity Bottles

ME-6937

The Aquatic Productivity Bottles rest in a rack that provides consistent and reliable light control for quantitative aquatic productivity studies. The identical transparent bottles nest in each of five rack positions. The custom design of the rack shields the bottles from light by blocking a fixed percentage of light in 25% increments from 0 to 100%.



The Aquatic Productivity Bottles were completely filled with algae solution and the initial dissolved oxygen (DO) concentrations of the solutions were determined with a DO sensor. The bottles were then placed into the rack and the specially molded, light-varying lid was locked into place over the bottles. After 24 hours of incubation in fluorescent light, the bottles were removed from the rack and the DO concentration was again determined with a DO sensor. Using the initial and final (DO), students calculate Net Primary Productivity and Gross Primary Productivity.

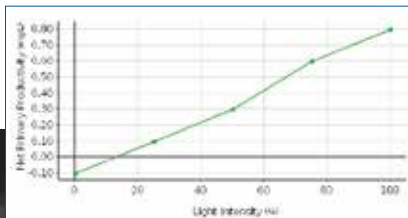

Net Primary Productivity (mg/L) vs. Light Intensity (%): notice that for the bottle in the dark, the Net Productivity is negative.



### Includes

- Plastic bottles w/lids (5)
- Case with slotted lid



### Order Information

Aquatic Productivity Bottles.....ME-6937  
 Shown in use with:  
 Optical Dissolved Oxygen Sensor.....PS-2196

## Blood Pressure

PS-2207 (Standard Cuff Size)

### PASPORT

With PASCO's Blood Pressure Sensor students easily measure heart rate (bpm) and systolic and diastolic arterial blood pressure (mmHg). Students gain a greater understanding of the physiology of the circulatory system when they also learn about the physiology of blood pressure. The systolic and diastolic pressure provided in the digits display can be used by the student to verify their own determination of blood pressure from the graph.

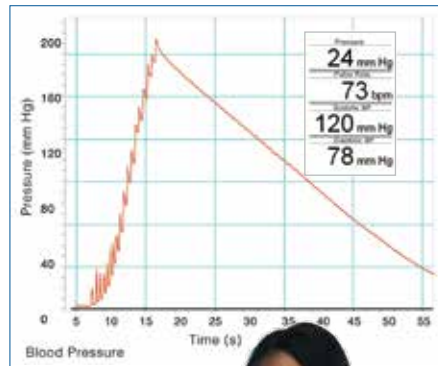

A student "patient" remains still while another student uses the pump to increase the pressure in the cuff. The students observe the graph as the pressure in the cuff slowly decreases. On the digits display, students observe the patient's heart rate and systolic and diastolic blood pressure.

### Experiment ideas

- ▶ Determine the effects of exercise on blood pressure and heart rate
- ▶ Explore the effects of body position on blood pressure and heart rate
- ▶ Compare the blood pressure and heart rate of students in the class

### Includes

- Blood Pressure Sensor
- Standard Arm Cuff
- Bladder
- Pressure Release Valve



### Order Information

Blood Pressure Sensor (Standard Cuff Size)..... PS-2207

# Physiology

## EKG

PS-2111  
**PASPORT**



The EKG Sensor measures electrical signals produced by the heart. As cardiac muscle depolarization and repolarization occur, the EKG trace graphically illustrates the beating of the heart. The sensor comes with 100 self-adhesive conductive patches that are easily removed from the skin after use.

### Typical Applications

- ▶ Generate a personal EKG graph
- ▶ Compare EKG graphs before and after mild exercise

### Specifications

#### EKG Waveform:

**Voltage:** 0 to 4.5 mV

**Resolution:** 4.5  $\mu$ V

#### Sample Rate:

50 to 200 samples per second (sps)

#### Default Sample Rate:

200 samples per second (sps)

#### Heart Rate (Beats):

**Range:** 47 to 250 beats per minute (bpm)

**Resolution:** 1 beat per minute (bpm)



*NOTE: The EKG Sensor has been designed for educational purposes only and is not suitable for medical diagnoses.*

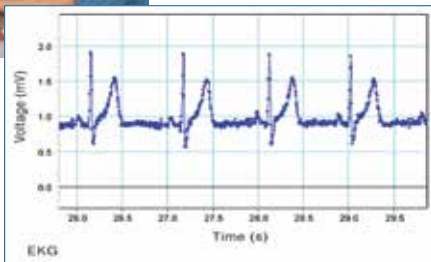

*Additional EKG Electrode Patches (CI-6620) may be ordered separately.*

### Order Information

EKG Sensor ..... PS-2111  
EKG Patches (100 each) ..... CI-6620

## Wireless Exercise Heart Rate Sensor



PS-3207



The Wireless Exercise Heart Rate Sensor has a chest strap and will transmit data wirelessly up to 10 m away! The electrode belt fits around the ribcage (worn against the skin for best results, but can be worn over a shirt if saline solution is applied under the electrodes) and wirelessly transmits the cardiac signal to the sensor.

### Typical Applications

- ▶ Compare a student's heart rate before, during, and after exercise
- ▶ Calculate recovery rate after physical activity
- ▶ Determine the effects of mild stimulants (e.g. caffeine)
- ▶ Investigate how heart rate changes when a student sits, reclines, stands or moves suddenly



*Graph shows the heart rate as a student alternates between exercise and resting.*

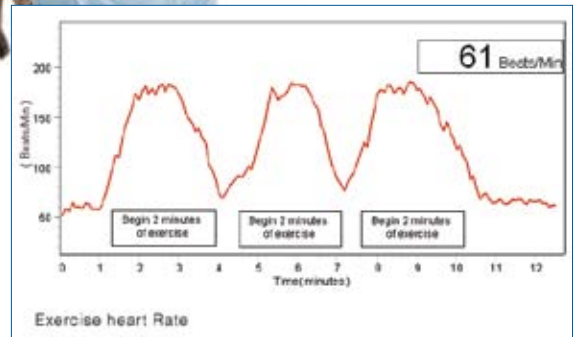

### Includes

- Bluetooth® Heart Rate Module
- Coin-cell battery (1)
- Chest strap (M-XXL)

### Order Information

Wireless Exercise Heart Rate Sensor..... PS-3207

## Wireless Hand-Grip Heart Rate Sensor



PS-3206



Using the new wireless Hand-Grip Heart Rate Sensor, it's easier than ever before to conduct physiology labs on the cardiovascular system or homeostasis. Use this sensor for a quick and easy way to acquire wireless measurement for either continuous monitoring or initial vs. final data points.

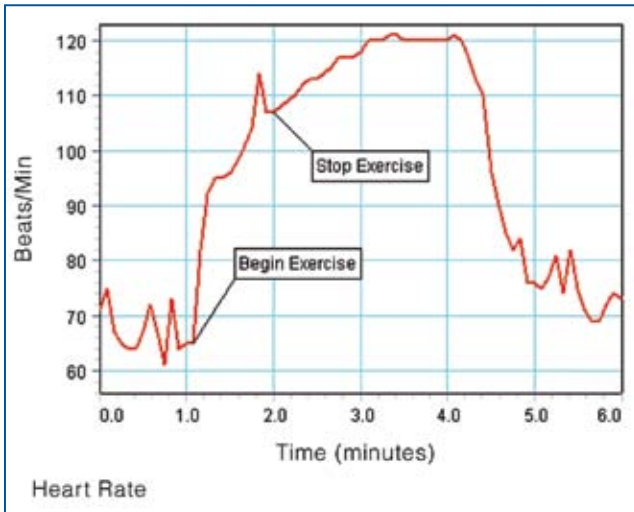

### Includes

- Hand-grips
- Bluetooth® Heart Rate Module
- Coin-cell battery (1)

### Order Information

Wireless Hand-Grip Heart Rate Sensor.....PS-3206

## Goniometer

PS-2137 **PASPORT**

- ▶ Accurately measures joint movements
- ▶ Flexible mounting options



PASCO's Goniometer helps students better understand physics because they use their bodies as the experimental apparatus. The Goniometer can be connected to the knee, hip, or elbow joints to measure angle changes during a variety of movements. Measure the angular position, velocity, and acceleration for the arm or leg.

The PS-2137 includes one Angle Sensor (PS-2139) and one Goniometer Probe with Velcro connection kit. To measure the motion of two joints simultaneously, simply purchase another Goniometer Probe separately.

### Specifications

- Range:** 0 to 120°
- Accuracy:** 2% of measurement
- Resolution:** 0.25°
- Maximum Sample Rate:** 500 Hz

Position and velocity of knee joint while running

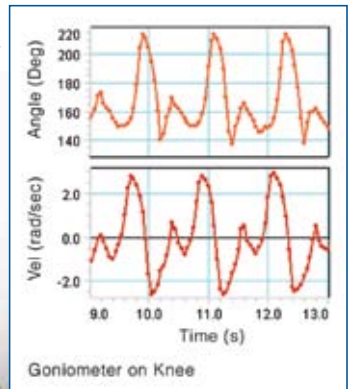

See page 139 for more information.

Developed in cooperation with Nancy Beverly, Assistant Professor of Physics at Mercy College, Dobbs Ferry, New York.

### Order Information

Goniometer Sensor .....PS-2137  
 Recommended:  
 Additional Goniometer Probe.....PS-2138

## Angle Sensor

PS-2139 **PASPORT**



The Angle Sensor measures angle by measuring resistance. It has two ports to accept two Goniometers (PS-2137) or the two probes in the joints of the Human Arm (PS-2611).

### Order Information

Angle Sensor .....PS-2139

# Biomechanics & Physiology

## Human Arm Model

PS-2611  
**PASPORT**



The Human Arm Model simulates the muscles and motion of an actual human arm. To activate the arm motion, students pull on the cord with a Force Sensor. Changes in position are measured at the shoulder and elbow using the two built-in potentiometers plugged into one Angle Sensor (PS-2139), included with PS-2611. Different arm muscles are activated depending on which pulleys are selected. Static force measurements can also be made to see how the muscle tension changes at various arm positions.

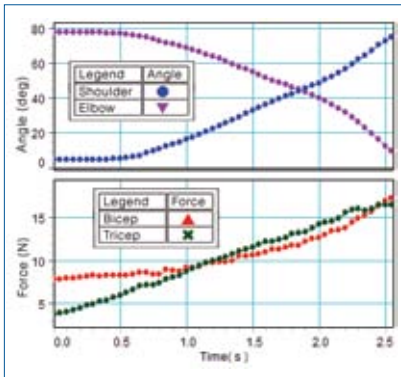

**Angles and Forces During Extension:** The upper graph shows the angles of the elbow (violet trace) and the shoulder (blue) as the arm is extended as shown in the picture below. Shown in the lower graph, the bicep tension (red) has little change at first and then rises sharply as the arm reaches out, while the tricep tension (green) rises steadily.

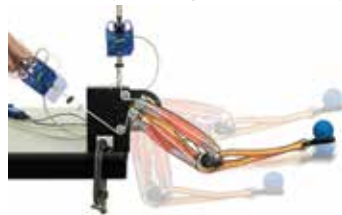

### Includes

- Human Arm Model
- Angle Sensor PS-2139

### Order Information

Human Arm Model.... PS-2611  
 Required for force measurement:  
 Wireless Force Acceleration  
 Sensor (2)..... PS-3202 p. 29

## Spirometer

PS-2152  
**PASPORT**



With our Spirometer Sensor students can measure airflow, duration, and lung volume. Disposable mouth pieces available for student safety.

### Typical Applications

- ▶ Compare a student's airflow before and after exercise
- ▶ Investigate the lung volume of athletes vs. non-athletes
- ▶ Compare smokers vs. non-smokers
- ▶ Conduct respiratory experiments
- ▶ Determine total lung capacity

### Specifications

- Displays volume in liters
- Minimal resistance to air flow
- Bi-directional air flow
- Sample Rate Range: 50 to 100 Hz



Measuring lung capacity.



Replaceable mouthpiece clips

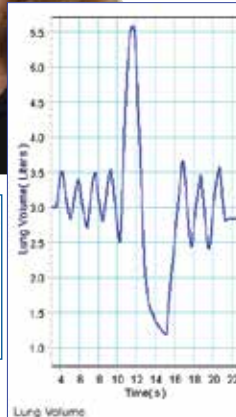

### Order Information

Spirometer Sensor..... PS-2152  
 Spirometer Mouth Pieces  
 (10-pack)..... PS-2522

## Breath Rate

PS-2187  
**PASPORT**

- ▶ Works while exercising



The Breath Rate Sensor uses standard disposable dust masks and gives stable output even when exercising. Breath rate is measured by sensing the pressure changes inside the mask. Tubing from the sensor connects to the disposable pressure clips that fasten on the side of the mask.

### Two Modes

- ▶ One reading every breath
- ▶ Running average over last four breaths



A graph showing a student's breath rate before, during, and after exercise.

### Includes

- Sensor with Tubing
- Pressure Clips (10)
- Masks (10)



### Order Information

Breath Rate Sensor..... PS-2187  
 Replacement Clips (10)..... PS-2568  
 Replacement Masks (10).... PS-2567

## Thermocline

PS-2151  
PASPORT

At last, students can measure temperature as a function of depth in local streams and lakes. PASCO's Thermocline measures depth automatically — no need to read markings on a cable and enter data manually. Weighted housing provides depth measurement stability in fast-flowing streams.



### Typical Applications

- ▶ Study thermoclines in fresh and salt water environments
- ▶ Create depth profiles for streams, small rivers, shorelines, and swimming pools
- ▶ Study ocean tides

### Specifications

#### Depth (pressure) -sensing element:

**Range:** 0 m to 10.5 m

**Accuracy:** 0.15 m (in fresh water after barometric pressure compensation)

**Resolution:** 0.03 m

#### Temperature-sensing element:

**Range:** 0°C to 100°C

**Accuracy:** ±1.5°C

**Maximum Sample Rate:** 10 Hz



The temperature of the water in a pond is measured as a function of depth.

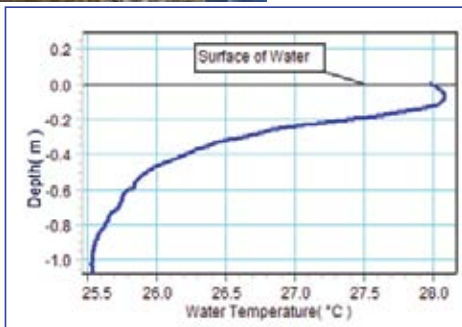

#### Order Information

Thermocline Sensor .....PS-2151

## Flow Rate/Temperature

PS-2130  
PASPORT

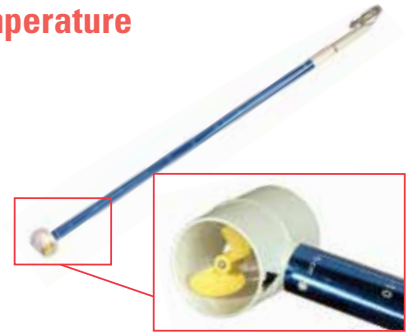

PASCO's Flow Rate Sensor allows students to measure the rate of movement and temperature of streams, rivers, and other flowing systems. The propeller is a rugged, single-piece unit encased by protective material — no more losing pieces at the bottom of the stream.

### Typical Applications

- ▶ Determine sediment transport rate for a stream or other body of water
- ▶ Measure and compare flow rate at various locations in a stream
- ▶ Compare the characteristics of one stream to another

### Specifications

**Flow Range:** 0 m/s to 3.5 m/s

**Temperature Range:** -10°C to 50°C

**Maximum Length:** 1.8 m (6 feet)

Telescoping handle to reach deep levels

**Maximum Sample Rate:** 20 Hz

### Special Features

- ▶ Revolutions of a magnet on the submersible propeller are counted and converted to linear flow rate measurements in ft/sec or m/s. Students can use PASCO Capstone™ software to calculate volume discharge rates.
- ▶ Exclusive built-in temperature sensor conveniently measures temperature at the same point as flow rate.



Graph shows the flow rates at the top (green), middle (orange), and bottom (brown) of a stream.

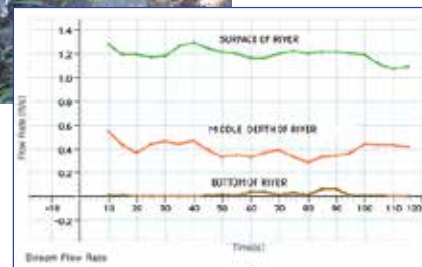

#### Order Information

Flow Rate/Temperature Sensor ..... PS-2130

# Environmental

## Salinity

PS-2195  
**PASPORT**

The PASPORT Salinity Sensor works with the 10X Salinity Sensor Probe to measure salinity, conductivity, and temperature. The sensor determines salinity based on electrical conductivity. The sensor has a built in calculation to compensate for the change in conductivity due to temperature change based on the Practical Salinity Scale (PSS).



The Salinity Sensor measures the electric current through a solution between the two platinized platinum electrodes in the Salinity Sensor Probe. The current through the solution is due to the movement of ions, so the higher the concentration of ions in the solution, the higher its conductivity. A voltage (AC) is applied across the two electrodes in the tip of the probe and the measured current is proportional to the conductivity of the solution.

### Typical Applications

- ▶ Explore the salinity of local water sources.
- ▶ Explore the interrelationship of salinity, temperature, and conductivity.
- ▶ Measure the change in the salinity of saltwater as the water evaporates.

### Examples of Water Salinity

- Fresh water:** <0.5 ppt
- Brackish water:** 0.5 to 30 ppt
- Saline water:** 30 to 50 ppt
- Ocean Water:** 35 ppt
- Brine:** >50 ppt

### Specifications

#### Measurement Ranges:

- Conductivity:** 1,000 to 100,000  $\mu\text{S}$
- Temperature:** 0 to 50°C
- Salinity:** 1 to 55 ppt  $\pm 1\%$  (with calibration)
- Sample Rate (maximum):** 50 Hz
- Temperature Compensation:**  $\pm 0.5$  ppt from 0 to 45°C at 33 ppt
- Cell Constant:** 10X

#### Order Information

- Salinity Sensor ..... PS-2195
- Recommended:*
- PASPORT Extension Cable ..... PS-2500

## General Flow Sensor

PS-2222  
**PASPORT**



The General Flow Sensor determines fluid velocity in air or water by measuring the difference in pressure between the two input tubes. Either the Venturi Tube or the Pitot Tube must be connected to the General Flow Sensor. The type of fluid (air or water) being used is selectable in the software.

See pages 172-173 for more information.

### Specifications

- Pressure Range:** 0 to 50 kPa
- Pressure Accuracy:**  $\pm 2.5\%$  of Full Scale (0 to 85°C)
- Resolution:** 0.2% of Full Scale
- Venturi Range:** 0 to 84 gpm (water); 0 to 773 gpm (air)
- Venturi Accuracy:**  $\pm 2.1$  gpm (water);  $\pm 2.5$  cf/min (air)
- Pitot Range:** 0 to 9.98 m/s (water); 0 to 92.1 m/s (air)

## Venturi Tube

ME-2220



The Venturi Tube is made of clear PVC so the water can be seen flowing through it. The Venturi Tube is connected to the General Flow Sensor by the matching couplers. The Venturi Tube slip joints are designed to be glued into any 3/4" PVC pipe network.

## Pitot Tube

ME-2221



The Pitot Tube is designed to be placed in the air flow or water flowing in a channel. The General Flow Sensor, connected to the Pitot Tube, measures the fluid velocity from the pressure difference.

#### Order Information

- General Flow Sensor without Probes ..... PS-2222
- Venturi Tube ..... ME-2220
- Pitot Tube ..... ME-2221
- Required:*
- PASPORT Interface ..... pp. 10-14
- PASCO Capstone Software ..... pp. 18-20
- Also Available:*
- General Flow Sensor with Venturi Tube ..... PS-2225
- General Flow Sensor with Pitot Tube ..... PS-2226
- Pressure Taps (set of 6) ..... ME-2224

**EcoZone™ System** ME-6668

**EcoChamber** ME-6667

- ▶ Three interconnected EcoChambers (ME-6668) or one stand-alone EcoChamber (ME-6667)
- ▶ Designed for sensor-based measurements

PASCO's EcoZone System is designed to help students model and understand the complex interactions within, and among, different ecosystems. The three clear acrylic EcoChambers are specially designed to accommodate PASCO sensors, making qualitative and quantitative measurements as easy as observing.

With three interconnected chambers, students can model the interaction between three different ecosystems. Choose the traditional terrestrial, aquatic, and decomposition arrangement or create unique biomes to model and measure. Decouple the system for isolated investigations: how does the availability of light affect the ecosystem? Students can create two identical ecosystems and monitor one in light conditions and one in dark.

Cleanup is easy, and the chambers are durable enough to use again and again. The unique design of the PASCO EcoZone System allows you to use your environmental science probes\* to actively measure a model ecosystem.

Keep the system closed during chemical testing – use the included syringe to extract water. Or inject pollutants into the system and see how the ecosystem responds.



Opening connects the chambers and allows the interaction between the living and non-living components of each unique ecosystem.



The included cord efficiently wicks water between the chambers.

Decomposition Chamber

Observe the photosynthesis and respiration cycles of the simulated microclimate in the EcoZone and their effect on carbon dioxide.

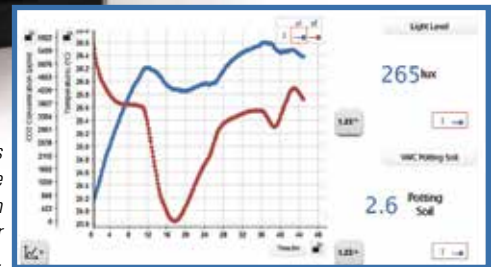

Terrestrial Chamber

Aquatic Chamber



**ME-6668 includes**

- Three individual EcoChambers with lids
- Custom tray for holding EcoChambers in a connected ecosystem
- Stoppers and connectors
- Cotton wick
- Syringe and plastic tubing



**ME-6667 includes**

- Acrylic chamber
- 7 stoppers of various sizes
- 5 probe stoppers
- 20 cc calibrated syringe and
- Sample tube with connector



**Order Information**

EcoZone System .....ME-6668  
 EcoChamber.....ME-6667

\*For more information on sensors and probes available for use with the EcoZone System, see [www.pasco.com/ecozone](http://www.pasco.com/ecozone) and select the Order Information tab.

# Environmental

**NEW**

## Wireless Weather Sensor with GPS

PS-3209



The Wireless Weather Sensor is an all-in-one instrument for monitoring environmental conditions. By incorporating several sensing elements into a single unit, the sensor provides up to **17 different measurements!** Use the sensor in logging mode with the Weather Vane Accessory for long-term monitoring, or use it as a hand-held instrument to study microclimates and record ambient conditions relevant to many biological and environmental phenomena.



*(Tripod and weather vane not included.)*

### Measurements

- |         |                          |
|---------|--------------------------|
| Weather | 1. Ambient Temperature   |
|         | 2. Barometric Pressure   |
|         | 3. Wind Speed            |
|         | 4. Wind Direction (true) |
|         | 5. Relative Humidity     |
|         | 6. Absolute Humidity     |
|         | 7. Dew Point             |
|         | 8. Windchill             |
|         | 9. Heat Stress Index     |
| Light   | 10. Ambient Light (lux)  |
|         | 11. UV Index             |
| GPS     | 12. Latitude             |
|         | 13. Longitude            |
|         | 14. Altitude             |
|         | 15. Speed                |
|         | 16. Magnetic Direction   |
|         | 17. True Direction       |



*This sensor can measure latitude, longitude, and other GPS functions!*

### Specifications

**Battery:** Rechargeable

**Water-resistance:** IP-64 splash-proof

(Please see pasco.com for detailed specifications.)

### Includes

- USB charging cable

### Order Information

Wireless Weather Sensor with GPS ..... PS-3209

*Suggested:*

Weather Vane Accessory ..... PS-3533

p. 73

**NEW**

### Weather Vane Accessory

PS-3553



Equip your Wireless Weather Sensor for extended environmental monitoring with the Weather Vane Accessory. Once deployed the sensor will freely rotate to capture wind speed and direction, whether you are monitoring data in real time or using the sensor in logging mode to capture hours (or days!) of data for later analysis.



**Includes**

- Tripod
- Tripod adapter
- Weather vane

**Order Information**

Weather Vane Accessory ..... PS-3553

### Soil Moisture

PS-2163  
**PASPORT**



The Soil Moisture Sensor measures the water content of soil and reports it in percent. It can be used to conduct experiments in environmental science, agricultural science, horticulture, and biology.

**Typical Applications**

- ▶ Measure the loss of soil moisture over time due to evaporation and plant uptake
- ▶ Evaluate optimum soil moisture contents for various species of plants
- ▶ Monitor soil moisture content to control irrigation in greenhouses



Soil moisture data over time shows evaporation.

**Specifications**

- Sensor Range:** 0 to 45% volumetric water content in soil
- Sensor Probe Length:** 5.5 cm
- Sensor Probe Cable Length:** 5 m
- Accuracy:** ±4%
- Resolution:** 0.1%
- Power:** 3 mA at 5 V DC
- Operating Temperature:** -40 to 60°C
- Default Sample Rate:** 10 samples per second

**Order Information**

Soil Moisture Sensor..... PS-2163

**NEW****Wireless Colorimeter and Turbidity**

PS-3215



The Wireless Colorimeter simultaneously measures the absorbance and transmittance of six different wavelengths. The sensor can be used to study enzyme activity, photosynthesis, and the rates of chemical reactions. By using the accessory cuvettes and a calibration standard, the colorimeter also functions as a turbidimeter for water quality analysis.



Measure the absorbance and transmittance of a solution at six different wavelengths... simultaneously!

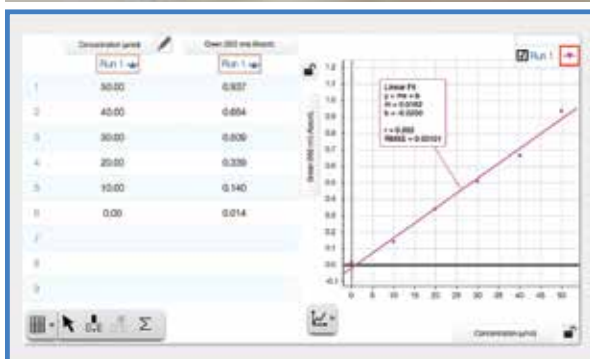

Create Beer's Law plots to help students understand the relationship between absorbance and concentration.



Graphically analyze how a reaction changes over time.

**Specifications**

**Color detection/peak wavelengths detected:** 650 nm (red), 600 nm (orange), 570 nm (yellow), 550 nm (green), 500 nm (blue), 450 nm (violet)

**Detector ranges:**  $\pm 25$  nm from peak

**Absorbance:** 0-3 Abs units; useful range (0.05 -1.5 Abs)

**Transmittance:** 0-100%

**Turbidity range:** 0-400 NTU

**Accuracy:** +5% NTU

**Includes**

- USB charging cable
- Cuvettes (9)
- 100 NTU Calibration Cuvette (1)
- Cuvette racks (2)

**Order Information**

Wireless Colorimeter and Turbidity Sensor ..... PS-3215

*Also available:*

Turbidity Sensor ..... PS-2122

Replacement Cuvettes/Caps (6 each) ..... SE-8739

100 NTU Cal Standard ..... PS-2511

Cuvette Rack ..... SE-8777

## Water Quality Colorimeter

PS-2179  
**PASPORT**

This PASPORT Water Quality Colorimeter is designed specifically to support chemical analysis of water samples using PASCO's ezSample Snap Vial water quality test kits.



Complete with built-in calibration curves to determine the concentration of ions in the solution for the ions listed on this page. Simple to use in the field and students avoid direct contact with chemicals!

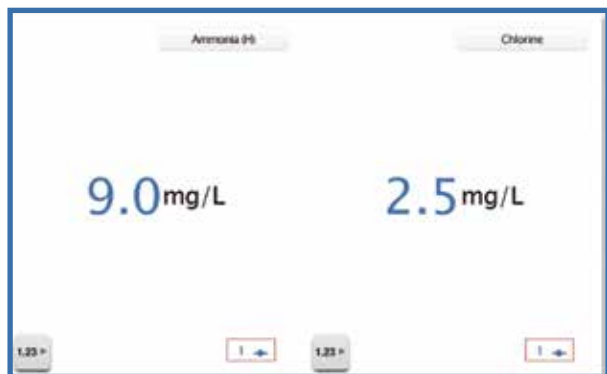

Iron concentration using ezSample Snap Vial and Water Quality Colorimeter.

### Specifications

#### Measurable Ranges:

ezSample Snap Vials (Colorimetric)

Iron	0 to 7 mg/l
Nitrate	0 to 2 mg/l
Ammonia	0 to 3 mg/l
Phosphate	0 to 8 mg/l
Chlorine	0 to 6 mg/l

ezSample Field Titrators

Total Hardness	20 to 200 mg/l
CO <sub>2</sub>	10 to 100 mg/l
Alkalinity	10 to 100 mg/l

**Operating Temperature:** 0° to 40°C

### Order Information

Water Quality Colorimeter..... PS-2179

Available Test Kits\*: (30 tests per kit)

ezSample Snap Vials (Colorimetric)

Iron	EZ-2331
Nitrate	EZ-2333B
Ammonium	EZ-2334A
Phosphate	EZ-2337
Chlorine	EZ-2339A

ezSample Field Titrators

Total Hardness	EZ-2338
CO <sub>2</sub>	EZ-2341
Alkalinity	EZ-2340

## Wireless Conductivity

PS-3210



Use the Wireless Conductivity Sensor to measure the electrical conductivity of a water solution. With this wireless sensor you can investigate the properties of solutions, as well as model and measure water quality.

### Features

- ▶ Measure both conductivity and total dissolved solids
- ▶ Automatic temperature compensation
- ▶ Dust- and sand-proof and water-resistant
- ▶ Battery life >1 year



### Includes

- 1 coin cell battery

### Order Information

Wireless Conductivity..... PS-3210

# Comprehensive Physics Systems

## 850 Comprehensive Physics System

UI-5800B

### ► Designed for the 850 Universal Interface and PASCO Capstone™ Software

The 850 Comprehensive Physics System consists of 83 experiments and all the equipment and sensors needed to perform these experiments. The experiments span the topics of mechanics, waves, optics, thermodynamics, and electromagnetism (see page 78 for a complete list of experiments). The equipment and sensor bundles for the three subject areas are shown on these two pages.

The included experiment manual contains instructions written in Word®, a PASCO Capstone electronic workbook, and sample data.

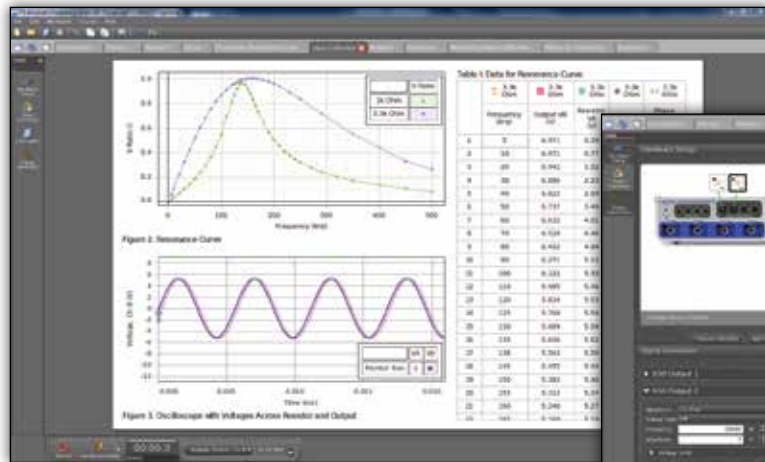

See page 78 for list of experiments in the included manual. Download free experiments at [pasco.com/850experiments](http://pasco.com/850experiments)

## Comprehensive Mechanics

UI-5801B

(Component of the 850 Comprehensive System UI-5800B)

### UI-5801B Includes

Part No.	Description
ME-6622	Force Bracket
CI-6691	Mini Rotational Accessory
ME-6743	Cart Adapter
ME-6755	Compact Cart Mass (2)
ME-6806	Pi Set
ME-6810	Time-of-Flight Accessory
ME-6821A	Photogate Mounting Bracket
ME-6825A	Mini Projectile Launcher
ME-6828	Magnetic Damping Accessory
ME-6829	Mini Launcher Ballistic Pendulum Accessory
ME-6843	Spring Cart Launcher
ME-6950	PAScar (Set of 2)
ME-6977	Super Fan Cart
ME-8569	Density Set
ME-8574	Discover Friction Accessory
ME-8735	Large Rod Base
ME-8736	Rod, stainless steel, 45 cm
ME-8738	Rod, stainless steel, 90 cm
ME-8933	Smart Timer Picket Fences (2)
ME-8971	Endstops (Set of 2)
ME-8972	Track Feet (Set of 2)
ME-8979	Mass and Hanger Set
ME-8998	Elastic Bumper
ME-8999	Dynamics Track Spring Set (12)
ME-9377A	Picket Fence
ME-9436	Pivot Clamp
ME-9472	Large Table Clamp
ME-9493	1.2 m Dynamics Track
ME-9498A	PASCO Photogate Head (2)

Part No.	Description
ME-9506	Pendulum Clamp
ME-9507	Multi Clamp (2)
ME-9595	Car Sail
ME-9781	Variable Speed Motorized Cart
ME-9821	Centripetal Force Pendulum
PS-2103A	Motion Sensor (2)
PS-2136A	3-Axis Acceleration/Altimeter
PS-2120	Rotary Motion Sensor
PS-2189	High Resolution Force Sensor (2)
SA-9242	Pulley Mounting Rod
SE-7347	No Bounce Pad
SE-8050	String, spool
UI-5813	Comprehensive 850 Experiment Manual



NOTE: The 850 Universal Interface (UI-5000) must be purchased separately.

The key to a successful lab is a PASCO Capstone electronic workbook. These workbooks have step-by-step instructions with live embedded displays such as graphs, FFTs, oscilloscopes, and meters. They contain the theory, experiment set-up, procedure, data analysis, and questions designed to get the students to think about their results.

These electronic workbooks can be easily modified by teachers to fit their individual needs.

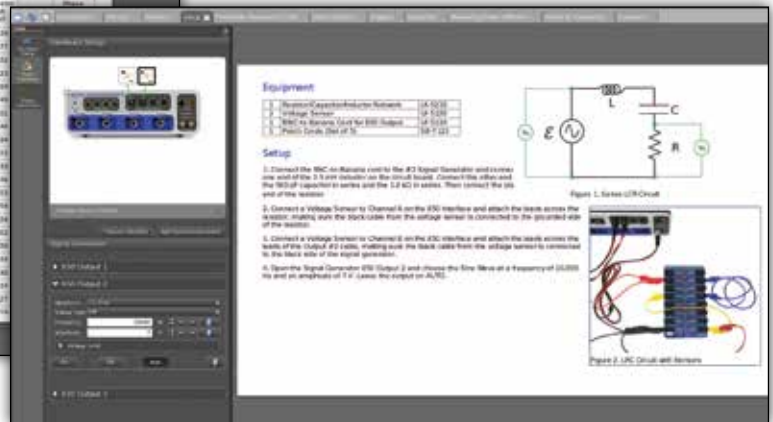

### Order Information

850 Comprehensive Physics System	UI-5800B
Required:	
850 Universal Interface	UI-5000 pp. 12-13
PASCO Capstone™ Software	pp. 18-20

### Want Mechanics Only?

850 Comprehensive Mechanics	UI-5801B
-----------------------------	----------

## Comprehensive Waves, Optics, and Thermodynamics

UI-5802 (Component of the 850 Comprehensive System UI-5800B)



### UI-5802 Includes

Part No.	Description
CI-6506B	Sound Sensor
ET-8499	ET Calorimeter
OS-8453	High-Precision Diffraction Slits
OS-8458	Green Laser
OS-8495	Color Mixer Accessory Kit
OS-8496	Color Mixer
OS-8515C	Basic Optics System
OS-8525A	Red Laser
OS-8533A	Polarization Analyzer
OS-8535	Linear Translator
OS-8494	Adjustable Focal Length Lens
PS-2107	Absolute Pressure
PS-2143	Quad Temp
PS-2176	High Sensitivity Light Sensor
SE-7345	Resonance Box Set
SE-9750	Red Patch Cords
TD-8570	Radiation Cans
TD-8595	Absolute Zero Apparatus
TD-8596A	Ideal Gas Law Apparatus
WA-9495	Economy Resonance Tube
WA-9857	String Vibrator
WA-9900	Open Speaker

The experiments for this section require some of the components of the 850 Comprehensive Mechanics UI-5801B.

## Comprehensive Electromagnetism

UI-5803 (Component of the 850 Comprehensive System UI-5800B)



See page 78 for manual. Download free experiments at [pasco.com/850experiments](http://pasco.com/850experiments)

### UI-5803 Includes

Part No.	Description	Part No.	Description
EM-8620	Bar Magnets (pair)	SE-7123	Short Patch Cords
EM-8652	Zero Gauss Chamber	SE-8680	Plotting Compasses
EM-8656	AC/DC Electronics Laboratory	SF-8619	Dip Needle
ES-9080B	Electrostatics System	UI-5100	Voltage Sensors (4)
PK-9023	Field Mapper Kit	UI-5119	BNC Funct. Gen Cables
PS-2184	Current Probes (2)	UI-5210	Circuit Board
PS-2162	Mag Field Sensor 2-axis		

The experiments for this section require some of the components of the 850 Comprehensive Mechanics UI-5801B.

### Comprehensive 850 Physics System (UI-5800B) Includes

- ▶ Comprehensive Mechanics UI-5801B
- ▶ Comprehensive Waves, Optics, and Thermodynamics UI-5802
- ▶ Comprehensive Electromagnetism UI-5803

### Order Information

850 Comprehensive Physics System.....UI-5800B

Required:

850 Universal Interface.....UI-5000 pp. 12-13

PASCO Capstone Software..... pp. 18-20

Also Available Separately:

850 Comprehensive Mechanics.....UI-5801B

850 Comprehensive Waves, Optics, and Thermodynamics.....UI-5802

850 Comprehensive Electromagnetism.....UI-5803

850 Comprehensive Physics System Manual.....UI-5813

See page 78 for list of experiments in the included manual.

# Comprehensive Physics Systems

## Comprehensive 850 Physics System Experiment Manual

UI-5813

See pages 76-77 for the equipment bundles needed for these experiments.

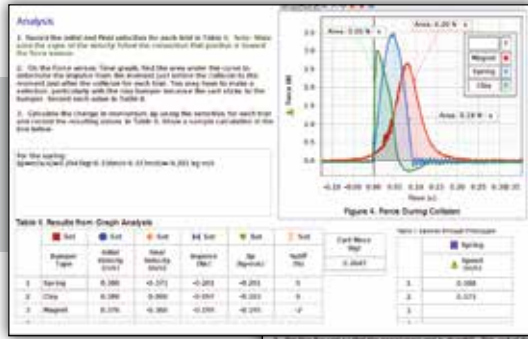

Included with the Comprehensive 850 Physics System are 87 experiments on a flash drive, each with a PASCO Capstone electronic workbook for the students, another workbook with sample data, and a Microsoft Word® document.

### Comprehensive 850 Physics System Experiment List

#### Mechanics (49 Experiments)

- Introduction to Measurement
- Uncertainty and Error Analysis
- Relative Motion in One Dimension
- Match Graph: Position and Velocity vs. Time
- Instantaneous and Average Speed
- Position and Velocity
- Velocity and Acceleration
- Equations of Motion
- Acceleration of a Freely Falling Ball
- Acceleration of a Freely Falling Picket Fence
- Acceleration: on an Incline
- Projectile Motion
- Projectile Motion – Against a Wall
- Newton’s First Law – No Net Force
- Newton’s Second Law
- Force and Acceleration
- Inertia and Newton’s Second Law
- Newton’s Third Law
- External Forces and Newton’s Third Law
- Atwood’s Machine
- Acceleration up an Inclined Plane
- Static Equilibrium
- Coefficients of Static and Sliding Friction
- Friction and Newton’s Laws
- Magnetic Drag
- Terminal Velocity for Objects of Different Surface Areas and Masses
- Centripetal Force on a Pendulum
- Conservation of Energy on an Inclined Plane
- Gravitational Potential Energy
- Hooke’s Law and Elastic Potential Energy
- Conservation of Energy for a Simple Pendulum
- Work-Energy Theorem
- Conservation of Momentum in Collisions
- Impulse and Change in Momentum
- Ballistic Pendulum
- Newton’s Second Law for Rotation
- Rotational Inertia
- Rotational Kinetic Energy
- Conservation of Angular Momentum

#### Waves, Optics, and Thermodynamics (22 Experiments)

- Heat and Temperature
- Transfer of Energy by Radiation
- Specific Heat
- Electrical Equivalent of Heat
- Boyle’s Law: P and V of a Gas at Constant T
- Absolute Zero
- Behavior and Characteristics of Sound Waves
- Standing Waves on a String
- Resonant Modes of Sound in a Tube
- Speed of Sound in Air
- Superposition of Sound Waves
- Interference of Sound Waves
- Shadow and Color in Light
- Object and Image Distances for a Thin Lens
- Reflection and Refraction
- Focal Length of a Concave Mirror
- Optical Instruments: Telescope and Microscope
- Variation of Light Intensity
- Light Intensity versus Distance
- Polarization: Verify Malus’ Law
- Brewster’s Angle
- Diffraction of Light

#### Electromagnetism (16 Experiments)

- Electrostatic Charges
- Electric Field Mapping
- Ohm’s Law
- Series/Parallel Circuits
- Kirchhoff’s Laws: Resistors in Series and Parallel
- Capacitance
- RC Circuit
- Resonant Frequency of an LRC Circuit
- General Properties of Diodes
- Build a Rectifier
- Transistor 1 – The NPN Transistor as a Digital Switch
- Transistor 2 – Measure the Current Gain
- Earth’s Magnetic Field
- Magnetic Field Mapping
- Induction – Magnet Through a Coil
- Magnetic Field in a Current-Carrying Coil

This manual is included in both the 850 Comprehensive Physics System UI-5800 and the 850 Comprehensive Mechanics System UI-5801.

Download free experiments at [pasco.com/850experiments](http://pasco.com/850experiments)

#### Order Information

Comprehensive 850 Physics System Experiment Manual (Flash Drive).....UI-5813

Word® files, PASCO Capstone files, and graphics are supplied on a flash drive.

## 850 Mechanics System (includes 850 Universal Interface)

UI-5820

- ▶ Integrates probeware and physics equipment
- ▶ Includes 850 Universal Interface
- ▶ Perform a wide variety of mechanics experiments

When used together, PASCO's probeware and physics apparatus can help students learn the major concepts of mechanics more effectively. The Mechanics 850 System includes the 850 and equipment required to perform a wide variety of mechanics experiments.

The new manual consists of 10 PASCO Capstone electronic workbooks with complete experiments that take full advantage of the components of this system. Sample data files are included.



**Impulse Experiment**  
Measure the force as a function of time as the cart hits the spring and also measure the change in momentum using the photogate.

### Ten Experiments Included in Manual (UI-5821)

Title	Purpose	Sensors Used
Acceleration Down an Incline	Discover how the acceleration of an object down an incline depends on the angle of incline. Measure the acceleration due to gravity.	Photogate with picket fence
Newton's Second Law	Verify Newton's Second Law by varying the applied force and the mass.	Motion Sensor
Kinetic Friction I	Measure the kinetic coefficient of friction.	Motion Sensor
Kinetic Friction II	Study how the coefficient of kinetic friction depends on the velocity, acceleration, surface area, and weight of the object.	Photogate with pulley
Impulse and Momentum	Measure the impact force of a cart and compare the impulse to its change in momentum.	Force Sensor/ photogate
Conservation of Momentum in Explosions	Verify that momentum is conserved for two carts pushing off from each other.	Two photogates with picket fences
Conservation of Momentum in Inelastic Collisions	Verify that momentum is conserved in inelastic collisions and that kinetic energy is not conserved.	Two photogates with picket fences
Conservation of Momentum in Elastic Collisions	Verify that momentum is conserved in elastic collisions.	Two photogates with picket fences
Conservation of Energy	Show spring potential change into kinetic energy.	Motion Sensor/ photogate with picket fence
Simple Harmonic Motion	Measure the period of oscillation of a spring and mass system and compare it to the theoretical value. Evaluate the effect of changing the mass and spring constants.	Photogate and flag



#### UI-5820 Includes

1. UI-5000	850 Universal Interface	p. 11
2. PS-2189	High Resolution Force Sensor	p. 31
3. PS-2103A	Motion Sensor	p. 26
4. ME-9471A	Photogates and Fences	p. 40
5. ME-8574	Discover Friction Accessory	p. 111
6. ME-9429B	1.2 m Classic Dynamics System	p. 96
7. ME-6622	Force Bracket	p. 30
8. ME-8979	Mass and Hanger Set	p. 187
9. ME-9491	Fan Accessory	p. 107
10. UI-5821	Lab Manual (not shown)	

#### Order Information

850 Mechanics System.....	UI-5820
<i>Required:</i>	
PASCO Capstone™ Software.....	pp. 18-20

## Advanced Physics through Inquiry 1 Experiment Guide

PS-2848

**This experiment guide covers the new standards for College Board Advanced Placement Physics 1.**

- ▶ Every lab is based on the College Board Learning Objectives.
- ▶ Data Analysis and Assessment Questions are designed to prepare students for the AP® Physics 1 exam.
- ▶ Every lab employs the same strategies found in free response questions on the AP® exam.
- ▶ Includes editable student handouts.

**Prepare your students for inquiry investigations in the physics lab. Each lab is presented three ways:**

- ▶ Structured
- ▶ Guided inquiry
- ▶ Student designed

**You decide which level of inquiry is appropriate for each lab.**

**Each lab includes teacher resources**

- ▶ Pre-lab discussion and questions
- ▶ Procedural overview
- ▶ Teacher tips
- ▶ Sample data
- ▶ Assessment and synthesis questions
- ▶ Extended inquiry suggestions

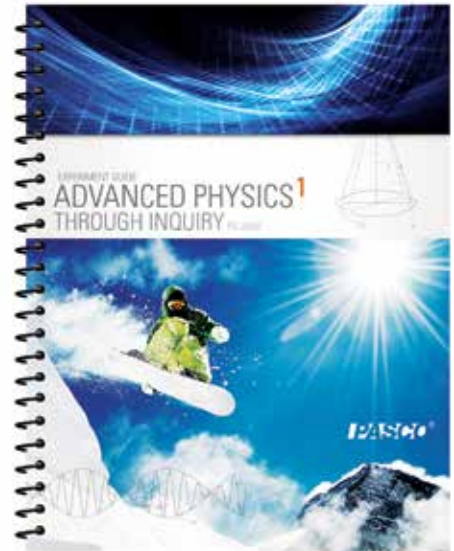

**Order Information**

Advanced Physics through Inquiry 1  
Experiment Guide.....PS-2848

ADV PHYSICS 1 EXPERIMENTS	SENSORS					ALIGNMENT	
	Motion	High Resolution Force	Smart Gate	Rotary Motion	Voltage/Current	IB Standards*	AP Standards**
1. Graphical Analysis: Motion	●					2.1	3.A.1
2. Newton's Second Law	●	●				2.2	3.B.1, 3.B.2
3. Atwood's Machine			●			2.2	3.B.1
4. Coefficients of Friction	●	●				2.2	3.C.4
5. Two Dimensional Motion: Projectiles			●			1.3, 2.1	3.E.1
6. Conservation of Mechanical Energy			●			2.3	5.B.4
7. Work and Kinetic Energy			●			2.3	4.C.2
8. Conservation of Momentum	●					2.4	5.D.2
9. Momentum and Impulse	●	●				2.4	3.D.2
10. Rotational Dynamics				●		B.1	3.F.2, 3.A.1
11. Rotational Statics						B.1	3.F.1
12. Periodic Motion: Mass and Spring		●				4.1, 9.1	3.B.3
13. Simple Pendulum			●			4.1, 9.1	3.B.3
14. Resonance and Standing Waves						B.4	6.3.D, 6.3.4
15. DC Circuits					●	5.1-5.3	1.B.1, 5.B.9, 5.C.3

\* IB is a registered trademark of the International Baccalaureate Organization, which was not involved in the production of, and does not endorse, this product.  
 \*\* AP is a trademark registered and/or owned by the College Board, which was not involved in the production of, and does not endorse, this product.

**Each experiment guide includes video support!**

How-to videos are included with the manual, on the PASCO web site and on YouTube, and can be installed on your own computers.



**Try It!**



### Advanced Physics I Starter Bundle

PS-2815



Part #	Equipment	Qty
1.	ME-6950 PAScar (Set of 2)	1
2.	ME-8574 Discover Friction Accessory	1
3.	ME-8752 Photogate Pendulum Set	1
4.	ME-8971 Dynamics Track End Stop (2 pack)	1
5.	ME-6960 PAStrack	1
6.	ME-6622 Force Bracket	1
7.	ME-8979 Mass and Hanger Set	1
8.	ME-9433 Super Pulley Kit	1
9.	ME-9495A Angle Indicator	1
10.	ME-9804 Cart Picket Fences (2 Pack) IDS	1
11.	ME-9806 Photogate Brackets (2 Pack) IDS	1
12.	ME-9836 Pivot Clamp IDS	1
13.	ME-9866 Demonstration Spring Set	1
14.	ME-9506 Pendulum Clamp	1
15.	ME-6757A 250 g Stackable Mass	3
16.	ME-6755 Compact Cart Mass	2
17.	PS-2103A PASPORT Motion Sensor	1
18.	PS-2180 Smart Gate	1
19.	PS-2189 PASPORT High Resolution Force Sensor	1

**Order Information**

Advanced Physics 1 Starter Bundle..... PS-2815

### Advanced Physics I Expansion Bundle

PS-2833

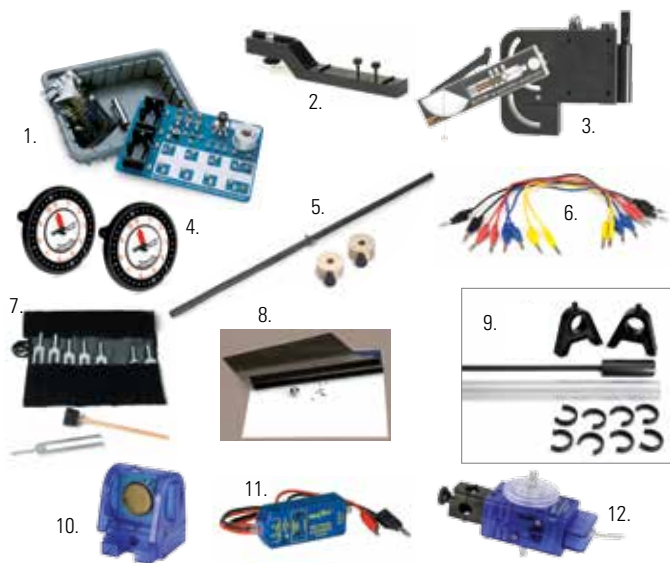

Part #	Equipment	Qty
1.	EM-8656 AC/DC Electronics Lab Kit	1
2.	ME-6821A Photogate Mounting Bracket	1
3.	ME-6825B Projectile Launcher (mini)	1
4.	ME-6855 Tension Protractor	2
5.	ME-8969 Pendulum Accessory	1
6.	SE-7123 4-mm Banana Plug Patch Cord Set	1
7.	SE-7342 Tuning Fork Set	1
8.	SE-8693 Carbon Paper (100 Sheets)	1
9.	WA-9606 Resonance Air Column	1
10.	PS-2103A PASPORT Motion Sensor	1
11.	PS-2115 PASPORT Voltage Current sensor	1
12.	PS-2120A PASPORT Rotary Motion Sensor	1

**Order Information**

Advanced Physics 1 Expansion Bundle..... PS-2833

## Advanced Physics through Inquiry 2 Experiment Guide

PS-2849

**This experiment guide covers the new standards for College Board Advanced Placement Physics 2.**

- ▶ Every lab is based on the College Board Learning Objectives.
- ▶ Data Analysis and Assessment Questions are designed to prepare students for the AP® Physics 2 exam.
- ▶ Every lab employs the same strategies found in free response questions on the AP® exam.
- ▶ Includes editable student handouts.

**Prepare your students for inquiry investigations in the physics lab. Each lab is presented three ways:**

- ▶ Structured
- ▶ Guided inquiry
- ▶ Student designed

**You decide which level of inquiry is appropriate for each lab.**

**Each lab includes teacher resources**

- ▶ Pre-lab discussion and questions
- ▶ Procedural overview
- ▶ Teacher tips
- ▶ Sample data
- ▶ Assessment and synthesis questions
- ▶ Extended inquiry suggestions

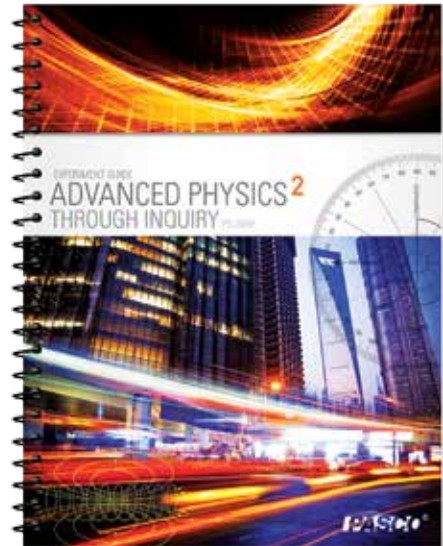

**Order Information**

Advanced Physics through Inquiry 2  
Experiment Guide.....PS-2849

**ADV PHYSICS 2 EXPERIMENTS**

	SENSORS							ALIGNMENT	
	Barometer/ Low Pressure	High Resolution Force	PASCO Optics Equipment	Digital Multimeter	2-Axis Magnetic Field Sensor	Voltage/Current	Rotary Motion	IB Standards*	AP Standards**
1. Hydrostatic Pressure	●							B.3	3.C.4, 5.B.10
2. Buoyant Force		●						B.3	3.C.4, 5.B.10
3. Fluid Dynamics	●							B.3	5.B.10
4. Boyle's Law	●							3.2	5.B.2, 7.A.3
5. Spherical Mirror Reflection			●					C.1	6.E.4
6. Snell's Law			●					4.4	6.E.3
7. Focal Length of a Converging Lens			●					C.1	6.E.5
8. Interference and Diffraction			●					4.4, 9.2, 9.3	6.C.3
9. Electric Field Mapping				●				5.1, 10.1	2.E.2
10. Magnetic Fields					●			5.4	2.D.3, 2.D.4
11. Magnetic Field Strength					●			5.4	2.D.2
12. Electromagnetic Induction						●	●	11.1	4.E.2
13. Capacitor Fundamentals				●				11.3	4.E.4
14. Series and Parallel Capacitors						●		11.3	4.E.5, 5.B.9
15. RC Circuits						●		11.3	4.E.5
16. Planck's Constant						●		12.1	6.F.3, 6.F.4

\* IB is a registered trademark of the International Baccalaureate Organization, which was not involved in the production of, and does not endorse, this product.

\*\* AP is a trademark registered and/or owned by the College Board, which was not involved in the production of, and does not endorse, this product.

**Each experiment guide includes video support!**

How-to videos are included with the manual, on the PASCO web site and on YouTube, and can be installed on your own computers.



*Try It!*



### Advanced Physics 2 Starter Bundle

PS-2863



Part #	Equipment
1. ME-6960	PASTrack
2. OS-8457	Concave Mirror Accessory, Half-Screen Accessory
3. OS-8460	Basic Optics Viewing Screen
4. OS-8465	Basic Optics Ray Table
5. OS-8466A	Converging lenses with known focal length
6. OS-8470	Basic Optics Light Source
7. OS-8472	Optics Carriages (3 pack)
8. OS-8474	Adjustable Lens Holder
9. PS-2113A	Barometer/Low Pressure Sensor
10. PS-2189	High Resolution Force Sensor
11. PS-2500	PASPORT Sensor Extension Cable
12. SE-8050	String
13. SE-8568	Overflow Can
14. SE-8805	Laser pointer with known wavelength

*Not Pictured:* OS-8850 Double Slit Diffraction Plate; Plastic cylinder; Metal cylinder; Syringe, 60-mL

#### Order Information

Advanced Physics 2 Starter Bundle..... PS-2863

### Advanced Physics 2 Expansion Bundle

PS-2868



Part #	Equipment
1. EM-8099	Induction Wand
2. EM-8618	Variable Gap Magnet
3. EM-8620	Alnico Bar Magnets (2 pack)
4. EM-8656	AC/DC Electronics Laboratory
5. PK-9023	Field Mapper Kit
6. PS-2112	Magnetic Field Sensor
7. PS-2115	Voltage-Current Sensor
8. PS-2120A	Rotary Motion Sensor
9. SB-9631B	Digital Multimeter (with Capacitance)
10. SE-7390	Magnaprobe
11. SE-8710	Stainless steel calipers
12. SE-9750	4-mm Banana Plug Patch Cord (5-pack)
13. SE-9756	4-mm Banana Plug Patch Cord Alligator Clip (10-pack)

*Not Pictured:* LED, Blue (450–500 nm); LED, Green (501–565 nm); LED, Yellow/Amber (566–620 nm); LED, Red (621–750 nm); LED, Infrared (751 nm–1 mm); Capacitor, 100  $\mu$ F; Magnet Wire

#### Order Information

Advanced Physics 2 Expansion Bundle..... PS-2868

# Essential Physics Curriculum

**This complete physics solution includes Textbook, e-Book, Digital Teacher Edition, and Equipment!**

Essential Physics 3rd Edition is a comprehensive, full-color textbook paired with PASCO equipment and the only e-Book for physics on the market. The program includes over 100 interactive tools that increase student engagement and understanding. Essential Physics is focused on practical applications that connect students to the physics of nature as well as technology.

## About the program:

- ▶ Rigorous yet accessible design
- ▶ Interactive simulations and equations
- ▶ Lessons follow the 5E design
- ▶ Strong mathematics scaffolding
- ▶ Formative and summative assessment tools
- ▶ Differentiation for advanced, below-level, and ELL students
- ▶ Works seamlessly with your LMS and Google Classroom
- ▶ Includes 24/7 online/offline access. No Internet required!

**Textbook**

**e-Book**

**Digital Teacher Edition**

**Equipment**

**Assessment**

- A box with a mass of 10 kg is resting on a floor. The coefficient of static friction between the box and the floor is 0.3. Estimate the force required to start the box sliding.
- Show a free-body diagram for a crate sliding across a level surface, including the force of kinetic friction.

**What is friction?**

Friction is a "catch-all" term that collectively refers to all forces caused by motion which act to reduce motion. Friction transforms energy of motion into thermal energy or the wearing away of moving surfaces.

**Calculating static friction**

A 10 N wood board is on a table. How much force does it take to make the board slide if  $\mu_s = 0.2$ ?

$$F_f = \mu_s F_N$$

$$= (0.2)(10 \text{ N}) = 2 \text{ N}$$

2 N is the minimum force needed to make the board start moving.

2 N is also the maximum force of static friction. The actual force of static friction is equal and opposite to any applied force up to the maximum.

Free-body diagram:  
 output: 10 N  
 $F_g = 10 \text{ N}$

**Essential Physics is multiplatform: iOS, Android™, Chrome™, Windows®, PC, and Mac®!**

# A textbook and e-Book for all your students

What sets *Essential Physics* apart is the complete and interactive e-Book. Animations, videos, and interactive equations and simulations bring concepts to life for students in ways that text and static images cannot. Combined with digital resources for teachers, formative and summative assessment, and equipment for lab investigations, *Essential Physics* forms a seamless learning system for mastering physics.

## Interactive tools include:

**31 videos**

**84 embedded interactive equations**

**Full audio read**

**31 embedded animations**

**71 interactive simulations**

**Summative assessment: The Infinite Test Bank**

**Formative assessment**

**Elastic potential energy**

A compressed spring stores elastic potential energy. A stretched rubber band also stores elastic potential energy. A battery stores electrical potential energy.

Different forms of potential energy

There are forms of potential energy other than gravitational. Potential energy exists any time a force is restrained from acting in such a way that the energy can be released. If you use the spring to launch a marble you can see how the stored potential energy of the spring is converted to kinetic energy of the marble. Compressing a spring creates potential energy because you have to do work against the force of the spring to compress it. A compressed spring stores potential energy as long as it is compressed. This type of potential energy is called **elastic potential energy** because it derives from the elasticity of the steel in the spring. It can be calculated by using equation (9.4).

(9.4)  $E_p = \frac{1}{2} kx^2$

$E_p$  = elastic potential energy (J)  
 $k$  = spring constant (N/m)  
 $x$  = displacement from equilibrium (m)

**Elastic PE of a spring**

**Video**

**Interactive equation**

**Finding magnitude from vector components**

Cartesian coordinates

$F_x = F \cos \theta$

$F_y = F \sin \theta$

Polar coordinates

$F = \sqrt{F_x^2 + F_y^2}$

$\theta = \tan^{-1} \left( \frac{F_y}{F_x} \right)$

**Magnitude**

$F = \sqrt{F_x^2 + F_y^2}$

$\theta = \tan^{-1} \left( \frac{F_y}{F_x} \right)$

**Rutherford scattering**

Metal foil target: Z=79, Au Gold

Alpha-particles escaping from "gun" at high velocity

Gold atoms: foil "target"

Target foil

Strongly deflected alpha particles: 27

Partially deflected alpha particles: 348

Undelected alpha particles: 397338

Run Print Reset Help

**Kinetic energy is lost in inelastic collisions**

There are two basic types of collisions in physics: elastic and inelastic. In an **inelastic collision**, some of the initial kinetic energy of the objects is transformed into heat and/or work to deform the shape of the objects. Auto collisions are nearly always inelastic, because of the damage caused to cars. In the special case of a **perfectly inelastic collision**, the two objects stick together.

**Perfectly inelastic collisions**

Before collision:  $v_{1i} = 7 \text{ m/s}$ ,  $m_1 = 1 \text{ kg}$ ,  $p_{1i} = 7 \text{ kg m/s}$ ;  $v_{2i} = -2 \text{ m/s}$ ,  $m_2 = 1 \text{ kg}$ ,  $p_{2i} = -2 \text{ kg m/s}$

After collision: balls stick together:  $v_f = 2.5 \text{ m/s}$ ,  $m_1 + m_2 = 2 \text{ kg}$ ,  $p_{f1} = 5 \text{ kg m/s}$

**Solving perfectly inelastic collisions**

A perfectly inelastic collision is depicted in the illustration above. These collision problems are solved in the same way as any other collision problem, using the conservation of momentum. Moreover, in the perfectly inelastic collision case the **final velocities** of the two objects are set to be equal—because the objects stick together!

**Section 14-2 Natural frequency and resonance**

Self Quiz: Questions: 1 2 3 4 5 Attempts: 0 Score: 0%

1. A pendulum is oscillating with a natural frequency  $f = 3 \text{ Hz}$ . If the length of the pendulum increases by a factor of 4 what happens to the frequency?

a) increases by a factor of 2  
 b) decreases by a factor of 4  
 c) increases by a factor of 4  
 d) does not change  
 e) decreases by a factor of 2

**Test your knowledge**

Ryan moves to the right with a positive velocity of 5 m/s for 1 s, then to the left with a negative velocity of -5 m/s for 1 s. What is Ryan's displacement after 2 s?

a. 5 m  
 b. 10 m  
 c. 0 m  
 d. -5 m

**Essential Physics meets 100% of your state standards and supports STEM and NGSS!**

The Digital Teacher Edition includes lesson plans, slide presentations, student work, and answer keys, all at point-of-use.

**Lesson resources:**

- Lesson plan: DOC/PDF
- Slide presentation: PPTX/PDF/Notes (PDF)
- Student work: DOC/PDF
- Answers: DOC/PDF

Friction is not a specific force in the same way that gravity is a force between two masses. Instead, friction is a "catch-all" term that collectively refers to forces that may be caused by motion and that act to reduce motion. Friction transforms the energy of motion into thermal energy or the wearing away of moving surfaces. Kinetic friction describes the friction between sliding surfaces and rolling friction describes friction in wheels. Static friction describes the tendency of objects to stick to each other and not move until a minimum force is applied to "break things loose."

**Some causes of friction**

**Friction** Everything that moves in the macroscopic world feels friction. We model the effect of friction as a force that is opposite in direction from actual motion, or the motion that *might* occur if there were no friction. Sliding, moving through air or water, or rolling are some forms of motion that generate friction that we can model this way.



**Air friction** comes from air being pushed aside or flowing around surfaces such as the body of a car or the wing of an aircraft.

**Rolling friction** comes from rolling contact between two surfaces, such as a wheel and the road.

**Sliding friction** comes from sliding contact between two surfaces, such as the bottom of skis and a snow-covered hill.

**Viscous friction** comes from liquids being displaced or forced to flow around or through objects such as pipes or boats.

**Where friction comes from** On a microscopic level friction comes from matter. Slippery liquids such as oil

**Lesson summary:** The lesson resources correspond to the content on these next six pages. The lesson presents the concept of friction as a force. Static, kinetic, and rolling friction are developed through the coefficient of friction model. Viscous friction is also mentioned.

**Present key content:** The general model of friction is a force that is a coefficient times the normal force. Equations

**Lesson resources:**

- Lesson plan: DOC/PDF
- Slide presentation: PPTX/PDF/Notes (PDF)
- Student work: DOC/PDF
- Answers: DOC/PDF

**LESSON PLAN** Essential Physics CHAPTER 5

**Friction**

**Content:** There are many forms of friction. This lesson introduces the force laws for static friction, kinetic friction, and rolling friction. Students learn the meaning of and typical range of values for the coefficients of friction. In the investigation, students determine the coefficients of static and kinetic friction between two surfaces.

**Learning objectives:** The student will be able to:  
 1) calculate friction forces from equation models for static, kinetic, and rolling friction; and  
 2) solve one-dimensional force problems including friction.

**Materials/technology resources:**  
 1) Slide presentation: "Friction.ppt"  
 2) Investigation: track with feet, friction block, thread, balance, Smart Cart with hook, 250-g cart masses (2)  
 3) SPARKvue file: "OSC\_Friction.apktab"  
 4) Student work: "FrictionAssignment.pdf"

**Lesson resources:**

- Lesson plan: DOC/PDF
- Slide presentation: PPTX/PDF/Notes (PDF)
- Student work: DOC/PDF
- Answers: DOC/PDF

**Lesson resources:**

- Lesson plan: DOC/PDF
- Slide presentation: PPTX/PDF/Notes (PDF)
- Student work: DOC/PDF
- Answers: DOC/PDF

**Investigation 5C: Static**

**Essential question:** What determines friction?

Friction is everywhere and can be either helpful or wasteful depending on the situation. In this investigation you will test models of friction against actual measurements to get a sense of how accurate these friction models are.

**Coefficient of static friction and kinetic friction**

1. Open the experiment file OSC\_Friction.apktab.
2. Set up the equipment like the picture, touching the hook.

**Table: Coefficient of static friction and kinetic friction**

Trial	Max Force (N)	Average Force While Sliding (N)	Mass of Block (kg)	Static Friction Coefficient $\mu_s$	Kinetic Friction Coefficient $\mu_k$	
1	11.0	5.08	1.125	0.46	0.21	
2	6.25	2.76	0.625	0.45	0.29	
3	3.75	1.55	0.375	0.42	0.27	
Average value for $\mu_s$ :				0.44	Average value for $\mu_k$ :	0.26

**Lesson resources:**

- Lesson plan: DOC/PDF
- Slide presentation: PPTX/PDF/Notes (PDF)
- Student work: DOC/PDF
- Answers: DOC/PDF

Get a textbook, e-Book, and equipment for the price of most textbooks!

### Essential Physics 3rd Edition Student Textbook

EP-6323

**Includes**

- Student hardbound textbook
- e-Book
- 24/7 online/offline access



### Essential Physics 3rd Edition Student Textbook

EP-6323-EBK

**Includes**

- e-Book
- 24/7 online/offline access



**Order Information**

Essential Physics 3rd Edition Student e-Book only ..... EP-6323-EBK

### Basic Equipment Kit EP-3571

▶ 17 labs are designed to use this equipment set.

Includes 1 of each of the following:

- Smart Cart (Blue), ME-1241
- Friction Block, ME-9807
- PAScar Cart Mass (set of 2), ME-6757A
- Angle Indicator, ME-9495A
- Track End Stop (set of 2), ME-8971
- Super Pulley with Clamp, ME-9448B
- Grattells Tray
- 1.2m Dynamics Track, ME-9493
- Track Feet (set of 2), ME-8972



**Order Information**

Basic Equipment Kit .....EP-3571

### Standard Equipment Kit EP-3567

▶ 25 labs are designed to use this equipment set.

Includes everything in the Basic Equipment Kit above + 1 of each of the following:

- Modular Circuits Standard Kit
- Wireless Current Module, EM-3534
- Wireless Voltage Sensor, PS-3211

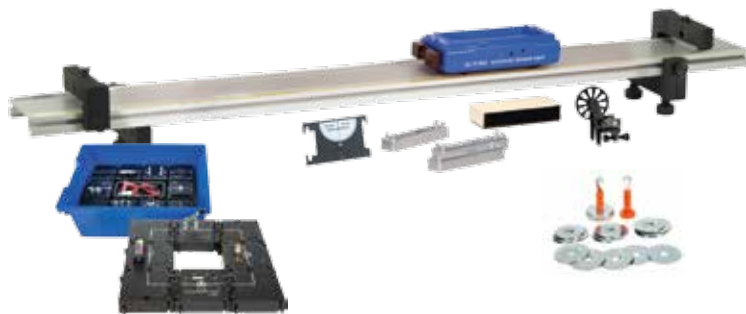

**Order Information**

Standard Equipment Kit .....EP-3567

### Comprehensive Equipment Kit EP-6490

▶ 41 labs are designed to use this equipment set.

Includes everything in the Standard Equipment Kit above + 1 of each of the following:

- Forces & Machines Engineering Kit
- Oscillations, Waves & Sound Kit
- Light Source
- Optics Components
- Tripod Stands (2) & Crossrail
- Forces Accessories



**Order Information**

Comprehensive Equipment Kit .....EP-6490

For complete information go to [pasco.com/essentialphysics](http://pasco.com/essentialphysics)

# Programming and Robotics with the ErgoBot



## Curriculum

### Programming and Robotics Teacher Resources

EP-6485

- ▶ 23 lessons and projects
- ▶ 7 interactive simulations
- ▶ Interactive IDE
- ▶ 23 slide presentations
- ▶ 23 student assignments
- ▶ Requires ErgoBot with ErgoBoard Robotics

Programming is one of the most valuable skills in the job market today and robotics is the cutting edge of technology. The ErgoBot Programming & Robotics system is a unique combination of hardware and software that makes it easier than ever before to get your students excited, engaged and successful with both.

This unique module offers 23 lessons and projects covering introductory and intermediate programming, robotics, sensors, code development, variables, loops, logic structures, autonomous operation, design, engineering, optimization and performance testing.

Hardware and software work together to make the easiest most engaging programming course ever created.



**Hardware and software work together to make the easiest most engaging programming course ever created.**

- ▶ No assembly required
- ▶ 23 projects start from novice level
- ▶ Works with Windows® and Mac® OS X.
- ▶ Wireless Bluetooth® communication
- ▶ Practical for every classroom
- ▶ Go to **pasco.com** for more info!

## Equipment

### ErgoBot with ErgoBoard Robotics

EP-6473

- ▶ Everything works right out of the box – nothing to solder or assemble.
- ▶ Designed for the classroom – use the same ErgoBot every period, all day.
- ▶ Projects 1-8 require no installed software. Students write easy code that gets the ErgoBot moving in less than 20 minutes.
- ▶ All three sensors are included and need only a few jumpers to connect.
- ▶ Build up to C-level programming language using logic and sensors.
- ▶ The teacher’s guide includes 23 projects with lessons, slides, and a wealth of instructional material.
- ▶ The Arduino-compatible ErgoBoard is available separately to upgrade your existing ErgoBot.

The ErgoBot Robotics system includes the ErgoBot, the Arduino-compatible ErgoBoard, an IR distance sensor, a 5-position IR skirt sensor for line following and more.

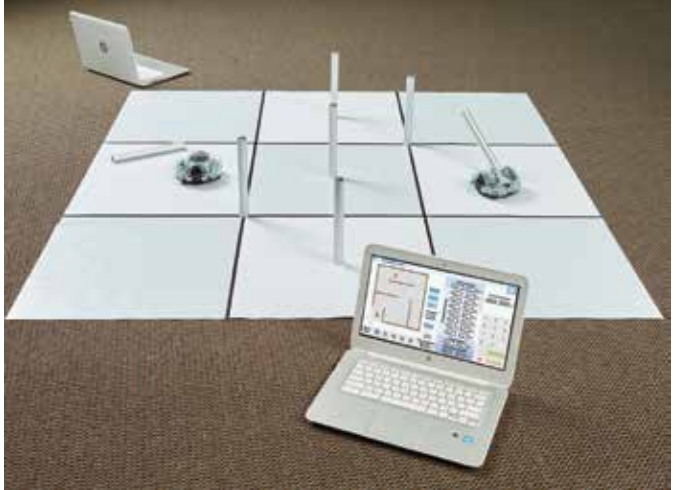

#### Order Information

ErgoBot Programming and Robotics Teacher Resources.....	EP-6485
<i>Required:</i>	
ErgoBot with ErgoBoard Robotics .....	EP-6473
<i>Also sold separately:</i>	
ErgoBot.....	EP-6471
ErgoBoard Robotics .....	EP-6472

### ErgoBot

EP-6471



Requires the Programming & Robotics Teacher Resources to function.

#### Order Information

ErgoBot .....	EP-6471
---------------	---------

### ErgoBoard with Sensors

EP-6472



Add the Arduino-compatible ErgoBoard and sensors to your ErgoBot to study robotics and programming (requires an ErgoBot for use).

#### Order Information

ErgoBoard with Sensors.....	EP-6472
-----------------------------	---------

# STEM Modules Curriculum and Equipment

## Light, Color, and Optics Teacher Resources

EP-6481

Introduce your students to the science and technology of light including reflection, refraction, color, intensity, lenses, mirrors, real and virtual images, human vision, digital imaging, and the quantum theory of light. For more information, visit [pasco.com](http://pasco.com)

- ▶ 12 lessons
- ▶ 5 interactive simulations
- ▶ 8 interactive equations
- ▶ 12 slide presentations
- ▶ 12 lesson plans
- ▶ 12 student assignments
- ▶ Requires Light and Optics kit

## Light, Color, and Optics Kit

EP-3558

### Includes

- 1.4 m extruded rail
- 50 mm optics mounts (3)
- Rechargeable light source
- AC adapter/charger
- Refraction tank
- Triangular prism
- Phosphorescent plastic
- 50 mm convex lens - 10 cm f.l.
- 50 mm convex lens - 20 cm f.l.
- 50 mm convex lens - 50 cm f.l.
- 50 mm concave lens - 20 cm f.l.
- 50 mm convex mirror - 20 cm f.l.
- 50 mm concave mirror - 50 cm f.l.
- 50 mm screen
- 50 mm diffraction grating
- Eyeglasses



### Order Information

Light, Color, and Optics  
Teacher Resources.....EP-6481

### Required:

Light, Color, and Optics Kit .....EP-3558

## Oscillations, Waves & Sound Teacher Resources

EP-6480

Teach the science and technology of waves and sound. Lessons cover harmonic motion, waves, sound, period, frequency, wavelength, resonance, Doppler effect, interference, frequency spectrum, multi-frequency sound, digital sound, human perception, and music. For more information, visit [pasco.com](http://pasco.com)

- ▶ 13 lessons
- ▶ 5 interactive simulations
- ▶ 8 interactive equations
- ▶ 13 slide presentations
- ▶ 13 lesson plans
- ▶ 13 student assignments
- ▶ Requires Waves and Sound kit

## Oscillations, Waves and Sound Kit

EP-3578

### Includes

- Steel transverse wave "snaky" spring (1.8 m)
- Extra-large steel longitudinal wave "slinky" spring
- 25 cm extension spring
- Pendulum/spring hanger
- Resonance lever
- 1" diameter aluminum pendulum ball
- Resonance tube
- Tuning fork 256 Hz
- Tuning fork 320 Hz
- Tuning fork 284 Hz
- Tuning fork 512 Hz



### Order Information

Oscillations, Waves and Sound  
Teacher Resources.....EP-6480

### Required:

Oscillations, Waves and Sound Kit .....EP-3578

## Forces and Machines Teacher Resources

EP-6483

- ▶ A single teacher guide is all you need to outfit your class or lab.
- ▶ Complete with guided inquiry lab activities, suggested answers, and much more.
- ▶ Requires Forces and Machines Engineering kit

Questions are embedded throughout the activities, sequencing and key term challenges, opportunities to predict outcomes prior to data collection and post-lab multiple choice questions all help to make the connection between lectures and labs as seamless as possible. And they are all correlated to state and national standards. For more information, visit [pasco.com](http://pasco.com)



## Forces and Machines Engineering Kit

EP-3577

Our Forces and Machines Kit engages students in a wide range of physics, physical science, and engineering concepts. Two triple-pulley blocks make it easy to build machines with mechanical advantage up to 6:1. Build all three classes of levers with our pair of 20-cm levers, or combine gears, levers, and pulleys together to show how rotating machines work.

### Includes

- 27" extruded rails (2)
- 10 N metal spring scales (2)
- Tripod stands (2) & crossrail
- Universal spring hanger
- Right-angle connector with pulley (2)
- Fixed triple pulley block
- Hanging triple pulley block
- 25 cm Hooke's law spring
- Friction block
- Quick-attach gear hubs (4)
- Gear spacers (8)
- 20 cm levers (2)
- 60 tooth spur gears (2)
- 40 tooth spur gears (2)
- 20 tooth spur gears (3)
- 20 cm dia. large pulleys (2)



### Order Information

Forces and Machines Teacher Resources .....EP-6483

*Required:*

Forces and Machines Engineering Kit .....EP-3577

# How to choose the Dynamics System that's best for you.

## Select the type of track you want.

*Do you want metal or plastic tracks?*



### Metal Track Advantages

- ▶ Available in 1.2 m or 2.2 m lengths
- ▶ Straight and rigid
- ▶ Can do induced magnetic drag because it's conductive
- ▶ Feet can be placed at any position
- ▶ High-contrast scale



### Plastic Track Advantages

- ▶ Can add tracks to make as long as you want
- ▶ Lightweight
- ▶ Can add curved track to do hills
- ▶ Built-in feet
- ▶ Storage: 1-meter track disassembles into two 50-cm parts
- ▶ Less expensive

## Select the type of carts you want.

*Do you want metal or plastic or Smart Carts?*



### Metal Cart Advantages

- ▶ Red and blue for distinguishing in collisions
- ▶ More inertia
- ▶ Sturdy body
- ▶ User-replaceable wheels



### Plastic Cart Advantages

- ▶ Red and blue for distinguishing in collisions
- ▶ Least expensive
- ▶ Two string tie positions
- ▶ Plunger has a long throw.



### Smart Cart Advantages

- ▶ Red and blue for distinguishing in collisions
- ▶ Completely instrumented with all the sensors you need for dynamics
- ▶ Two string tie positions
- ▶ Bluetooth 4.0 wireless: No interface required

# Which system is best for you?

## Basic System *Just Carts and Track*

Example shown:  
ME-5705

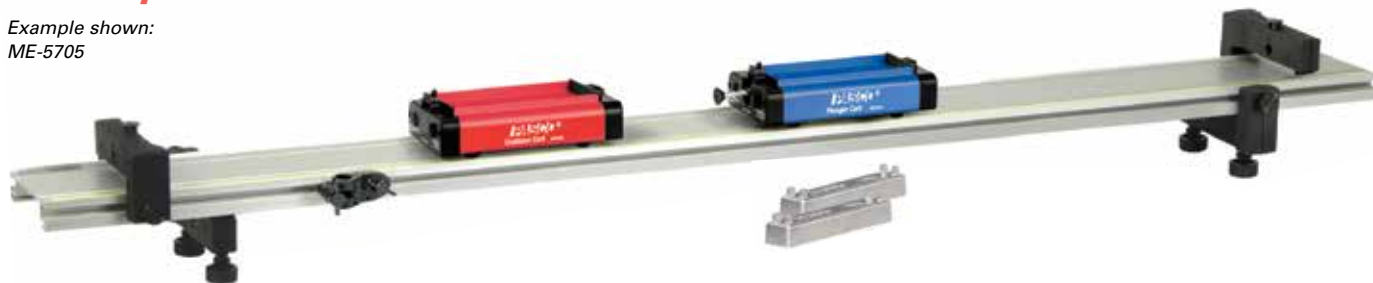

OR

## Standard System *Basic System + Accessory Pack*

Example shown:  
ME-5715



### Basic System includes

- ▶ Track
- ▶ 2 Carts
- ▶ 2 Feet
- ▶ 2 Endstops
- ▶ Rod Clamp
- ▶ 2 Mass Bars (4 with metal carts)

	Plastic Track 1 m	Metal Track 1.2 m	Metal Track 2.2 m
Plastic Carts	ME-5701	ME-5702	ME-5703
Metal Carts	ME-5704	ME-5705	ME-5706
Smart Carts	ME-5707	ME-5708	ME-5709

### Standard System includes

- ▶ Track
- ▶ 2 Carts
- ▶ 2 Feet
- ▶ 2 Endstops
- ▶ Rod Clamp
- ▶ 2 Mass Bars (4 with metal carts)
- ▶ Spring Set
- ▶ Clamp-on Super Pulley
- ▶ Friction Block
- ▶ Angle Indicator

	Plastic Track 1 m	Metal Track 1.2 m	Metal Track 2.2 m
Plastic Carts	ME-5711	ME-5712	ME-5713
Metal Carts	ME-5714	ME-5715	ME-5716
Smart Carts	ME-5717	ME-5718	ME-5719

# How to measure motion and forces on your dynamics system:

If you have a Smart Cart Dynamics System, you don't need any other sensors or interfaces.

## 1. Smart Cart

The Smart Cart has built-in sensors which measure its position, velocity, acceleration, force, and angular velocity. So there is no need to add any other external sensors. It's ready to measure, right out of the box. No interface is required because it connects wirelessly to any computing device.

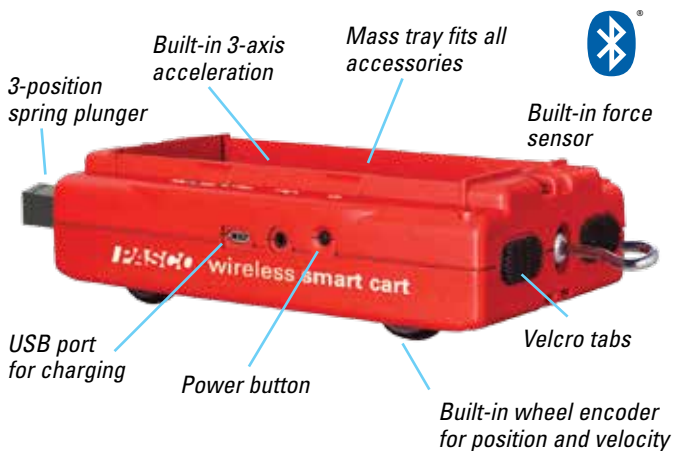

Smart Cart (Blue) ME-1241 Smart Cart (Red) ME-1240 (See page 98)

## 2. PASCO Capstone Software

The site license allows students to use it at home.



(See pages 18-20)

### Order Information

Smart Cart (Red).....	ME-1240
Smart Cart (Blue) .....	ME-1241
PASCO Capstone Software	
Single User License.....	UI-5401
Site License .....	UI-5400

**OR** If you have any other system, you need:

## 1. Wireless Force Acceleration Sensor (one or two)

We recommend the Wireless Force Sensors because they can ride in the carts without the added friction of a cord. Although a wired force sensor can be used mounted to the end of the track to show impulse, if you want to show the forces between two carts, the wireless force sensors are required.



Wireless Force Acceleration Sensor  
PS-3202 (See page 29)

## 2. Motion Sensors (2) OR Photogates (2)

Two Motion Sensors can track the velocity (speed and direction) of both carts throughout a collision for Conservation of Momentum experiments. Photogates have to be placed at just the right position to capture the before and after speeds.



## 3. An interface for the Motion Sensors or Photogates (550 or 850 Interface)

The 550 is sufficient for most labs, but the 850 will meet every need. Particularly for college labs.



## 4. PASCO Capstone Software

The site license allows students to use it at home.



(See pages 18-20)

### Order Information

Wireless Force Acceleration Sensor (order 1 or 2).....	PS-3202
Motion Sensor (order 2) .....	PS-2103A
Photogate Head (order 2).....	ME-9498A
Photogate Brackets (2).....	ME-9806
Smart Timer Picket Fences (2).....	ME-8933
550 Universal Interface (See p. 14).....	UI-5001
OR	
850 Universal Interface (See p. 12).....	UI-5000
PASCO Capstone Software	
Single User License.....	UI-5401
Site License .....	UI-5400

**OR** Without an Interface, you need:

1. *Wireless Force Acceleration Sensor (one or two)*



Wireless Force Acceleration Sensor  
PS-3202 (See page 29)

2. *Smart Timer with 2 Photogates*

The Smart Timer is battery powered and very easy to just set out on the lab bench and get going. However, on days when you want to measure force, you will still need a separate computing device for the wireless force sensors.



Smart Timer  
ME-8930  
(See page 114)



Photogate  
Heads  
ME-9498A  
Photogate  
Brackets  
ME-9806  
(See page 97)



Picket  
Fences  
ME-8933



3. *PASCO Capstone Software*

The site license allows students to use it at home.  
(See pages 18-20)



**Order Information**

Smart Timer.....	ME-8930
<i>Includes two fences, 9 VAC adapter and manual.</i>	
Wireless Force Acceleration Sensor (order 1 or 2).....	PS-3202
Photogate Head (order 2).....	ME-9498A
Photogate Brackets (2).....	ME-9806
PASCO Capstone Software	
Single User License.....	UI-5401
Site License .....	UI-5400

**OR** Traditional Approach, you need:

1. *Wireless Force Acceleration Sensor (one or two)*



Wireless Force Acceleration Sensor  
PS-3202 (See page 29)

2. *Tape Timer*

The Tape Timer gets you back to basics. Students measure the dots to get speed and plot speed vs. time to get acceleration. On days when you want to measure force, you will still need a separate computing device for the wireless force sensors.

Tape Timer Sensor  
ME-9283  
(See page 116)



3. *PASCO Capstone Software*

The site license allows students to use it at home.  
(See pages 18-20)



**Order Information**

Tape Timer.....	ME-9283
<i>Includes one roll of paper, 10 carbon paper discs, battery and manual.</i>	
Wireless Force Acceleration Sensor (order 1 or 2).....	PS-3202
PASCO Capstone Software	
Single User License.....	UI-5401
Site License .....	UI-5400

# Dynamics Systems Measurement

## Smart Gate

PS-2180

The Smart Gate connects directly to any PASPORT interface, and has an auxiliary port to daisy chain to an additional Photogate. Can be used with cart picket fence, clamp on super pulley, and flexible Photogate Tape.

### Smart Pulley

Use the Smart Gate and Photogate bracket with the Clamp-on Super Pulley to create a "smart pulley"

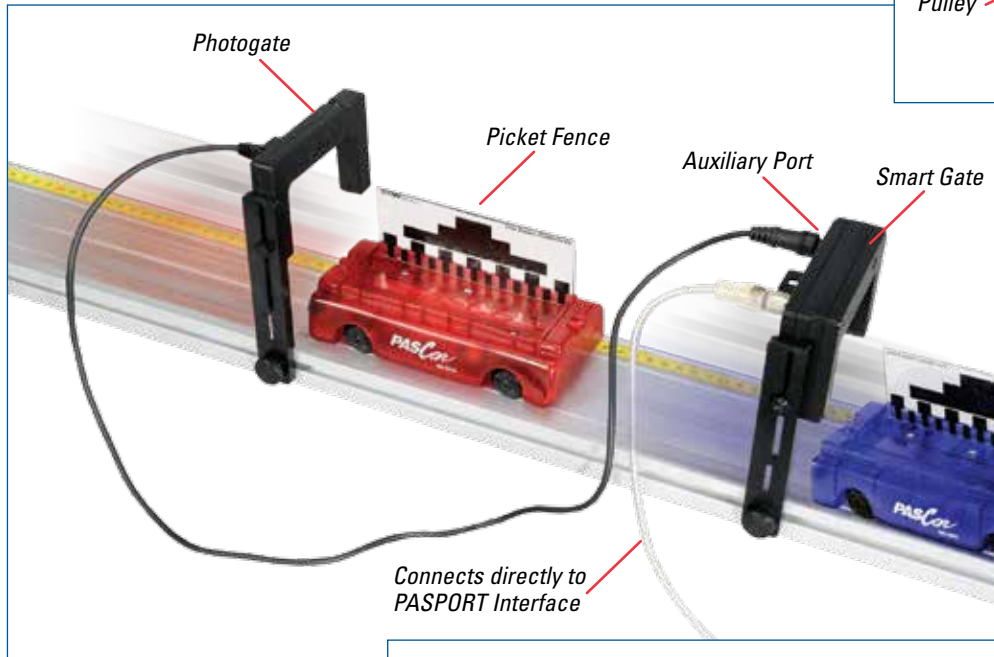
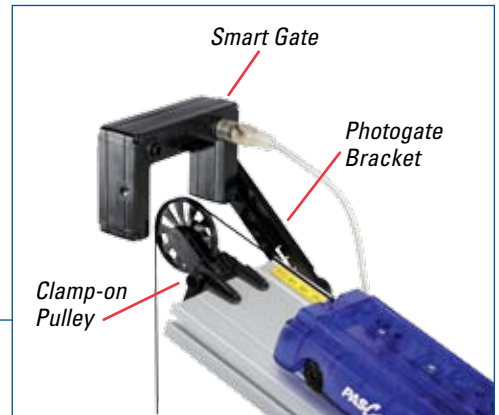

### Double Infrared Beams

Using the double beam of the Smart Gate, the velocity of the cart can be determined accurately using the front edge of a single flag.

### Auxiliary Port

A second photogate is connected to the Smart Gate Auxiliary Port so only one PASPORT port is required for two photogates.

### Photogate Tape Slot

The Smart Gate has a special slot through which the Photogate Tape can be threaded. This creates an excellent way of measuring the speed of the cart the full distance of the track as the cart accelerates down the inclined track.

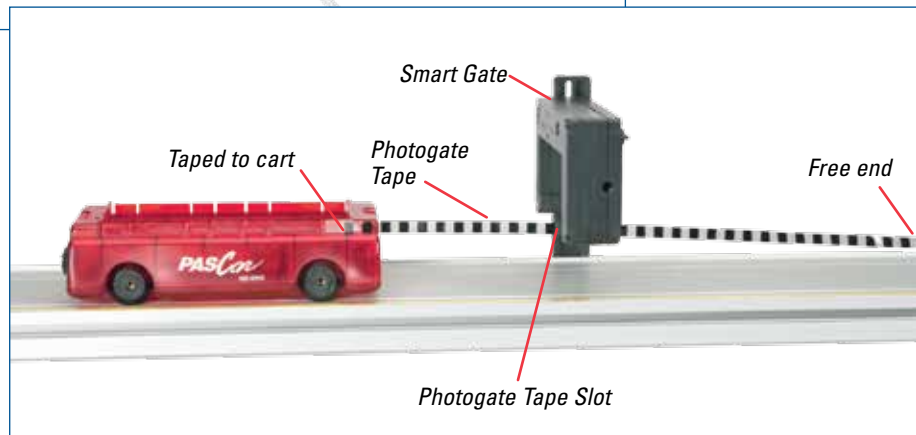

### Includes

- Smart Gate
- PASPORT Cable



### Order Information

Smart Gate .....	PS-2180	
<i>Recommended:</i>		
Photogate Head .....	ME-9498A	p. 37
High Resolution Photogate Tape .....	ME-6666	p. 38
Photogate Brackets (2) .....	ME-9806	p. 97
Cart Picket Fences (2) .....	ME-9804	p. 38
Super Pulley with Clamp .....	ME-9448B	p. 111

## Photogates and Fences

ME-9471A

When used with the computer for data recording, display, and analysis, the photogate/pulley timing system can provide a wide range of time, speed, and velocity measurements. The photogates mount to the dynamics track using the provided brackets. The picket fences provided mount directly to the dynamics carts.

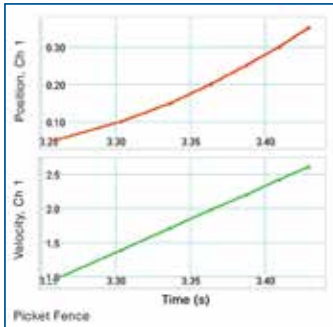

Position and velocity graphs are obtained using a Picket Fence and Photogate.

### Includes

- Photogate Heads (2)
- Photogate Brackets (2)
- Picket Fences (2)
- Super Pulley with attachment screw (attaches Super Pulley to Photogate)
- Pulley Mounting Rod



### Order Information

Photogates and Fences .....	ME-9471A	
<i>Individual Components:</i>		
Photogate Head .....	ME-9498A	p. 37
Photogate Brackets (2) .....	ME-9806	
Cart Picket Fences (2) .....	ME-9804	
Super Pulley .....	ME-9450A	p. 38
Pulley Mounting Rod .....	SA-9242	p. 38
<i>Required for use with PASPORT Interfaces:</i>		
Digital Adapter .....	PS-2159	p. 39

## Cart Picket Fences (set of 2)

ME-9804

### Order Information

Cart Picket Fences (set of 2) .....	ME-9804
-------------------------------------	---------



## Smart Timer Picket Fences (set of 2)

ME-8933

See Smart Timer on pages 126.

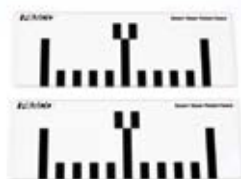

### Order Information

Smart Timer Picket Fences (set of 2) .....	ME-8933
--	---------

## Photogate Brackets

ME-9806 (2)

- ▶ Attaches Photogates to PASCO Dynamics Tracks
- ▶ Easily Adjust Photogate Height

The Photogate Bracket allows the Photogate Head to be attached directly to PASCO dynamics tracks. This eliminates the need for separate photogate stands and allows the photogate height to be easily adjusted relative to the track. Includes two Photogate Brackets.



(Photogates not included.)

### Order Information

Photogate Brackets (2) .....	ME-9806
------------------------------	---------

## Photogate Tape

ME-6666

Flexible Mylar® picket fence tape can be cut to any length. Tape slides into a Smart Gate to more accurately measure the motion of a cart.

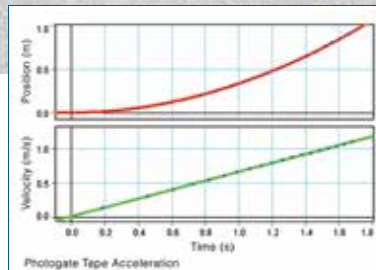
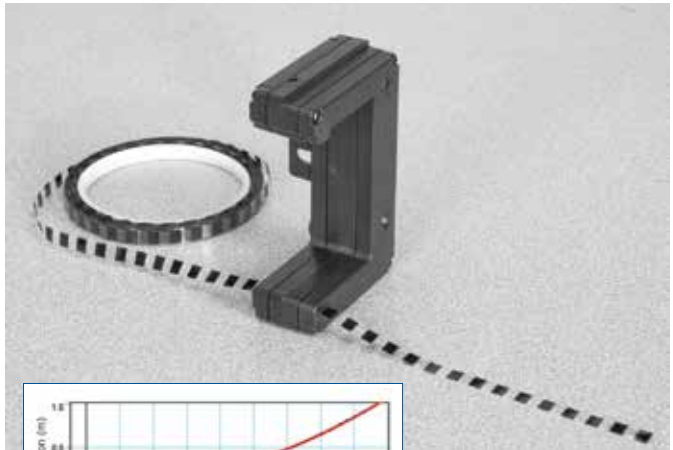

Photogate tape can be used as a picket fence "string" to continuously measure the motion of the cart.

Slide the photogate tape through the slot to measure position, velocity, and acceleration. The band spacing on the tape is 1 cm from edge to edge.

### Order Information

High Resolution Photogate Tape .....	ME-6666
<i>Required:</i>	
Smart Gate .....	PS-2180

p. 36

## Dynamics Carts

## Wireless Smart Cart

ME-1240 (Red) ME-1241 (Blue)



It is the ultimate tool for your physics lab with built-in sensors that measure force, position, velocity, and acceleration. The Smart Cart can make these measurements on or off a dynamics track and transmit the data wirelessly over Bluetooth®.

- ▶ Built-in force sensor ( $\pm 100$  N)
- ▶ Built-in 3D acceleration sensor ( $\pm 16$  g)
- ▶ Optical encoder for measuring motion
- ▶ Data is transmitted wirelessly
- ▶ No interface required
- ▶ Rechargeable lithium polymer battery

*Imagine the possibilities...*

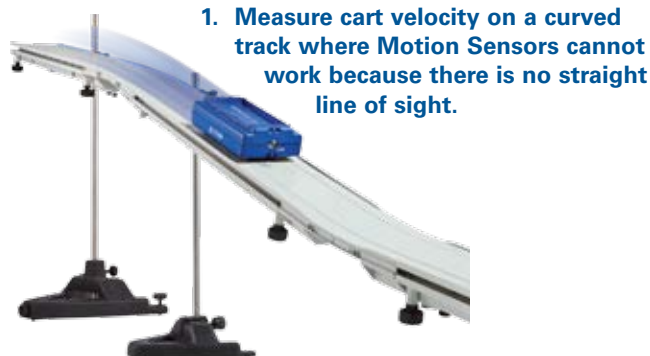

1. **Measure cart velocity on a curved track where Motion Sensors cannot work because there is no straight line of sight.**

### 3. Measuring oscillations of a cart and spring

Measure position, velocity, and acceleration of the cart, and force of the spring.



### 4. Cart on Floor or Table

Measure velocity as cart travels across the floor or table without a track.

### 5. Collisions with two Smart Carts:

Each cart measures its own velocity and force. Will your students correctly predict the forces recorded by each cart for the following parameters?

- ▶ Use equal masses and unequal masses.
- ▶ Use the same spring bumpers on the Smart Cart force sensors and then change the spring on one Smart Cart to a weaker spring.



The magnetic bumper for the force sensor is included with the Smart Cart.

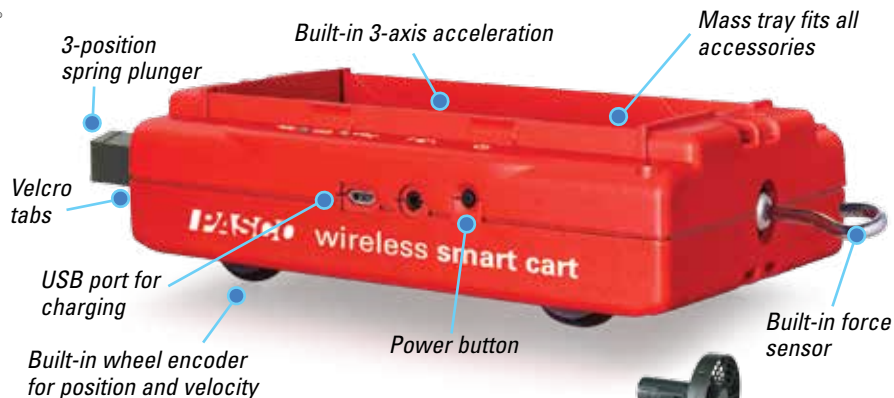

See the new Smart Fan Accessory on page 103.



### 2. Directly measure the tension in the string connected to the Smart Cart.

Hang a mass over a pulley, hold the cart in place, and then let go. When the cart is stationary, the tension is equal to the hanging weight. When the cart accelerates, the tension is less than the hanging weight.



### Smart Cart Includes

- Hook
- Rubber bumper
- Magnetic bumper
- USB cable for charging

## Smart Cart Charging Garage

ME-1243

Charge up to five Smart Carts at once. Provides storage for the carts and accessory bumpers. Includes power adapter.



Smart Carts not included.

### Order Information

Smart Cart Charging Garage .....ME-1243

### Order Information

Smart Cart (Red).....ME-1240

Smart Cart (Blue) .....ME-1241

*Recommended:*

Smart Cart Charging Garage .....ME-1243

*Shown in use with:*

PAStrack.....ME-6960

Curved PAStrack.....ME-6841

Magnetic Damping Bumper.....ME-6828

Round Base with Rod.....ME-8270

Smart Cart 1.2 m Dynamics System.....ME-5708

PASCO Capstone.....pp. 18-19

## PASCO Dynamics Carts

### PAScar

ME-6933 (Red) ME-6934 (Blue)

Each 250 gram polycarbonate plastic cart includes both a spring plunger, magnets and Velcro tabs for collision studies. The PAScars come in red and blue, and are compatible with all PASCO Dynamics Tracks and accessories.

#### Polycarbonate Body

Total mass: 250 g

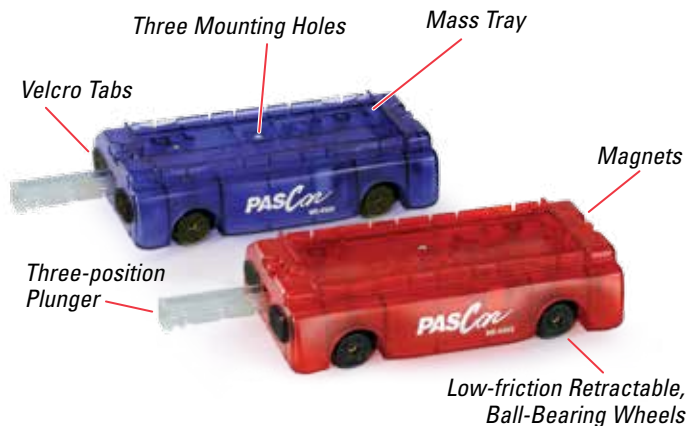

#### Order Information

PAScar (Red) .....	ME-6933	
PAScar (Blue) .....	ME-6934	
<i>Replacement Supplies:</i>		
Replacement Axles (4 pack) .....	ME-6957	p. 111
Cart Mass .....	ME-6757A	p. 111

### PAStack

ME-6960

#### Includes

- Two piece track
- Connector clips (2)
- Leveling feet (6)



#### Order Information

PAStack .....	ME-6960
---------------	---------

*Don't forget to add Cart Masses...*

### PAScar Cart Mass (set of 2)

ME-6757A

This 250 gram mass fits in any Dynamics Cart, the Motorized Cart (ME-9781), or the Discover Friction Accessory (ME-8574).



#### Order Information

PAScar Cart Mass (set of 2) .....	ME-6757A
-----------------------------------	----------

## Classic Aluminum Carts

### Plunger Cart

ME-9430 (Blue)

### Collision Cart

ME-9454 (Red)

These are the standard carts in thousands of physics labs around the world. With an aluminum body, high-impact ABS plastic end caps, and a 500 g mass, they make dynamics experiments quick to set up and very quantitative. The Classic Carts are compatible with all PASCO Dynamics Tracks and accessories.



#### Order Information

Plunger Cart (Blue) .....	ME-9430	
Collision Cart (Red) .....	ME-9454	
<i>Replacement Supplies:</i>		
Replacement Axles (4 pack) .....	ME-6957	p. 111
Cart Mass .....	ME-6757A	p. 111

## Aluminum Starter Tracks

1.2 and 2.2 meter Aluminum Tracks



**Have 1.2 m length tracks and want to change to 2.2 m?**

These aluminum tracks are available in 1.2 m and 2.2 m lengths.

#### Order Information

1.2 m Aluminum Starter Track .....	ME-9493
2.2 m Aluminum Starter Track .....	ME-9779

## PAstrack

### Straight PAstrack

ME-6960

- ▶ 1 m length dynamics track
- ▶ Two-piece molded construction
- ▶ Accepts dynamics track accessories

Two-piece track construction for easy storage. Snap-on connector clip holds sections straight and rigid. Use the second clip (included) to connect multiple tracks! The track ends are designed to accept the Motion Sensor and Clamp-on Pulley, and the side T-slots accept Dynamic Track accessories, such as photogate brackets and end stops. Track includes six built-in leveling feet.

#### Includes

- Two piece track
- Connector clips (2)
- Leveling feet (6)

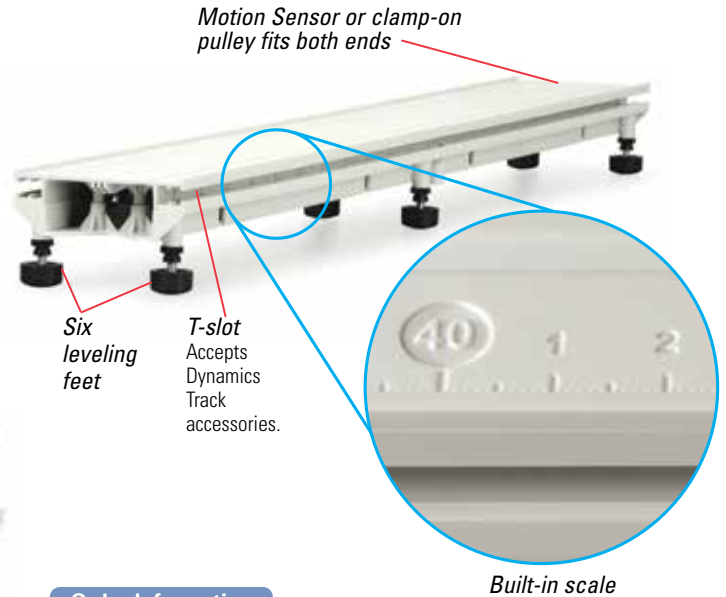

#### Order Information

Straight PAstrack .....ME-6960

## Add Curves to Your Dynamics Track

### Curved PAstrack

ME-6841

- ▶ Attaches to Straight PAstrack with same connector clip
- ▶ Put two curved pieces together
- ▶ One concave up and one concave down

Create hills, valleys and inclines. Molded PAstrack system has straight and curved sections that just snap together. Connect multiple sets to make a track as long as you want.



#### Includes

1. Concave-up Curved Piece
2. Concave-down Curved Piece
3. PAstrack Connector Clips (2)



Leveling feet



Built-in scale



Track just snaps together

#### Order Information

Curved PAstrack .....ME-6841

## Conservation of Energy Experiments

### Smart Cart Curved Track System

ME-5700A

- ▶ Explore all aspects of the Law of Conservation of Energy.
- ▶ Wireless Smart Cart has all the sensors you need.
- ▶ Use this system for all other dynamics experiments also.

This unique system has curved track that allows your students to build hills and valleys for Conservation of Energy experiments. Data is collected using the sensors onboard the Smart Cart. Unlike when Motion Sensors are used to track the cart, the Smart Cart does not have to be in the direct line of sight of the sensor so it can go over hills. And, the Smart Cart is wireless so no extra friction is introduced.

*Will the cart be going any faster at the bottom if a mass is added?  
With the Curved PASTrack and a low friction cart, students can investigate conservation of energy and answer that question.*

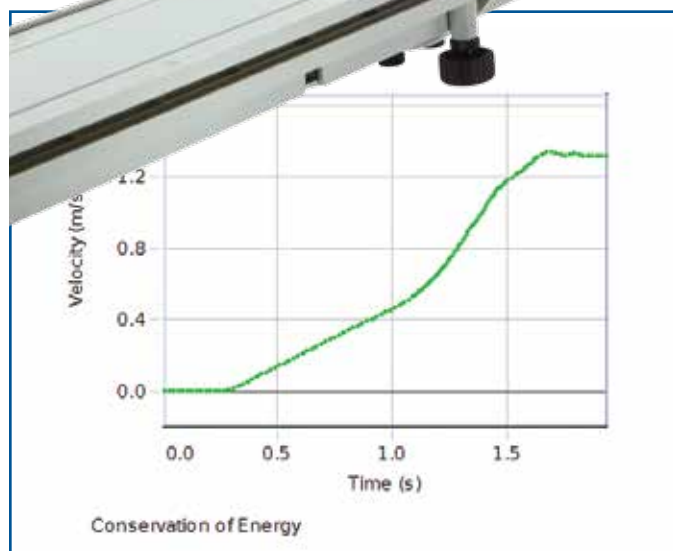

The curved and straight track pieces can be combined to form a step, so the cart starts out on a nearly level upper step, travels down the step, and ends on a level straight section. This makes measuring the change in height very easy.

During the experiments, the mass of the cart is varied to see what effect, if any, it has on the results.

Another configuration forms a potential well so the cart oscillates back-and-forth.

This versatile system can also be used for regular dynamics experiments such as impulse and Newton's Second Law.

**Experiments can be downloaded at [www.pasco.com](http://www.pasco.com).**



#### Includes

2 PASTrack (1 m)	ME-6960
2 Curved PASTrack	ME-6841
4 Pivot Clamp	ME-9836
1 Endstops (set of 2)	ME-8971
2 60 cm Threaded Rod	ME-8977
2 Round Base with Rod	ME-8270
2 Small A-Base	ME-8976
1 2 Masses	ME-6757A
1 Smart Cart Red	ME-1240

#### Order Information

Smart Cart Curved Track System.....ME-5700A

*Required:*

PASCO Capstone Software (see pages 18-20)

Bluetooth 4.0 compatible computer

# Powered Carts

## Motorized Cart

ME-9781

- ▶ Battery powered
- ▶ Adjustable speeds
- ▶ External power jack
- ▶ Climbs a 30° slope
- ▶ Durable construction

The tank-like molded casing and a rugged internal gear mechanism are built for the harshest student environment. Runs on four "C" batteries and has variable speed adjustment knob. External power input accepts phone plug cable (included) to power the car with a DC power supply or 850 Universal Interface signal generator.

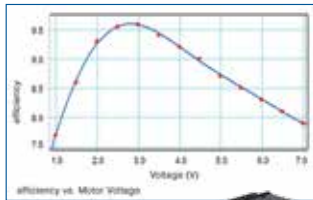

This graph shows effect of increasing motor voltage on the efficiency.

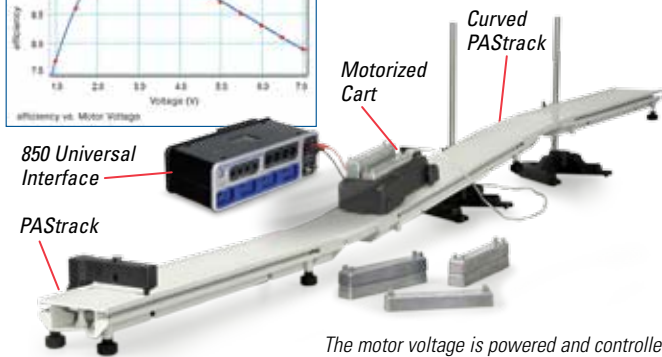

The motor voltage is powered and controlled using the 850 Universal Interface.

### Specifications

- Adjustable Speed:** ~ 8-25 cm/s
- Battery Power:** Four "C" (not included)
- External Power Input Jack**
- Battery Life (Alkaline):** Six hours

### Includes

- Motorized cart
- Cable for connecting to external power supply

### Order Information

Motorized Cart.....	ME-9781	
PASTrack.....	ME-6960	p. 100
Curved PASTrack.....	ME-6841	p. 100
250 g Stackable Masses (2 pack).....	ME-6757A	p. 111
Base and Support Rods.....	Various	p. 177

## Super Fan Cart

ME-6977

- ▶ Constant force
- ▶ Rechargeable
- ▶ Programmable

$$\vec{F}_{Net} = m\vec{a}$$

Teach every aspect of Newton's Second Law with PASCO's Super Fan Cart.

Adjust thrust angle to teach about vector forces  
Fan turns through 180°

### Rechargeable Battery

Lithium/polymer battery runs fan continuously on medium thrust for about 1.5 hours. Recharges in about 1 hour.

Vary the Mass without changing the Force  
Accessory Mass Tray for Compact Cart Masses (ME-6755).



### Adjustable Fan Speed

Apply different forces using three standard settings or the continuously variable setting. Regulated power supply gives constant thrust even as the battery discharges.

String Attachment  
Connect two fan carts together to add or subtract forces.

### The Net Force Is Zero

Removable sail can be used two ways: When positioned as shown, the sail cancels the forward air flow and there is no thrust. If the sail is reversed, its curved shape reflects the air backwards, causing the cart to move.



### Pulse Duration

Program fan to be pulsed on for specific time to demonstrate acceleration only occurs when a force is applied. Includes time delay and auto-repeat option.

### Specifications

- Fan Cart Mass:** Approximately 0.3 kg
- Sail Mass:** Approximately 0.1 kg
- Regulated Power Supply:** Lithium/polymer battery (7.2 volts, 1.25 amp-hour)
- Run-time:** Runs approximately 1.5 hr on medium thrust
- Recharge Time:** One hour typical
- Thrust Settings:** Approximately 0.04 N on Low, 0.15 N on Medium, and 0.22 N on High
- Thrust, Variable:** Approximately 0.01 N to 0.23 N

### Order Information

Super Fan Cart.....	ME-6977	
<i>Includes: Fan cart, sail and charger</i>		
<b>Recommended:</b>		
PASTrack.....	ME-6960	p. 100
Compact Cart Mass.....	ME-6755	p. 111
Motion Sensor.....	PS-2103A	p. 24
AirLink.....	PS-3200	p. 10

## Smart Fan Accessory



ME-1242

- ▶ Provides a Constant Force
- ▶ Hands-off Operation
- ▶ Sense and Control
- ▶ Manual Mode for Non-Smart Carts

### What makes this fan so smart?

If you use this fan on a regular cart, you can turn it on and select one of three speeds by pushing the button on the side. But plugging it into a Smart Cart gives this Smart Fan Accessory added capabilities:

- **Hands-off Operation:** You can turn the Smart Fan on and off wirelessly from your computing device.
- **Adjust the Thrust:** Move the slider in the software and watch the fan respond.
- **Reverse the Spin of the Fan:** Input a negative thrust to make the fan blow in the opposite direction.
- **Set Start and Stop Conditions:** Choose to start the fan when a measurement (such as Position) reaches a certain value. Make the fan stop after a certain time so the cart coasts during part of the experiment.
- **Sense and Control:** Program the Smart Fan thrust to respond to a calculation based on sensor measurements, for example:  
 $Thrust = -100 * [Position]$



This will cause the fan to blow harder as the cart moves down the track, causing the cart to reverse, and eventually the fan will reverse when the Position becomes negative, accelerating the cart in the positive direction.

### Specifications

- Pushbutton for on/off: 3 speed settings
- Fits all PASCO dynamics carts
- Smart Cart required for extended Smart features
- Maximum Thrust: 0.2 N
- Uses 4 AA batteries (alkaline or rechargeable)
- Lithium Battery Performance: On medium speed, fan slows after 5.2 hrs and stops after 5.6 hrs.
- Alkaline Battery Performance: On medium speed, fan slows after 1 hr and stops after 8.9 hrs.
- PASCO Capstone software required for full feature set.
- SPARKvue software provides ON/OFF button and thrust slider.



**Make your fan rotatable:**  
3D print your own rotating base for the Smart Fan Accessory at [pasco.com/diy](http://pasco.com/diy)

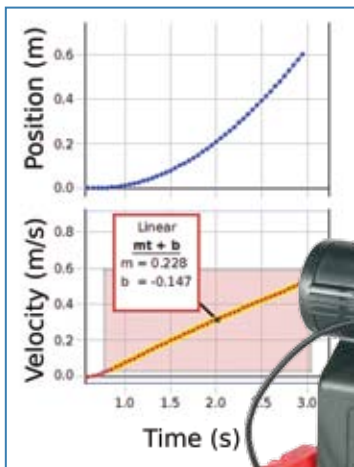
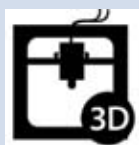

The Smart Fan Accessory becomes smart when plugged into a Smart Cart.



This is the control panel for the Smart Fan in PASCO Capstone software.

### Includes

- Smart Fan Accessory
- Smart Cart Cable (19 cm)
- AA Alkaline Batteries (4)



### Order Information

Smart Fan Accessory ..... ME-1242  
**Requires:**  
 Smart Cart or Dynamics Cart ..... pp.98-99  
 PASCO Capstone Software ..... p.19  
**Suggested:**  
 Battery Charger with 8 AA Rechargeable Batteries ..... SE-3570

## Cart Accessories

Show independence of  $x$ - and  $y$ -motion

## Ballistic Cart Accessory

ME-9486

- ▶ Works every time
- ▶ Non-contact release
- ▶ Adjustable barrel

PASCO's Ballistic Cart Accessory helps beginning physics students grasp the independence of vertical and horizontal motion.

## How It Works

Mounted on a dynamics cart or motorized cart moving at constant velocity, the Ballistic Cart Accessory launches a ball vertically, continues down the track, and then catches the ball as it falls—every time. Offers an exciting introductory demonstration to projectile motion.

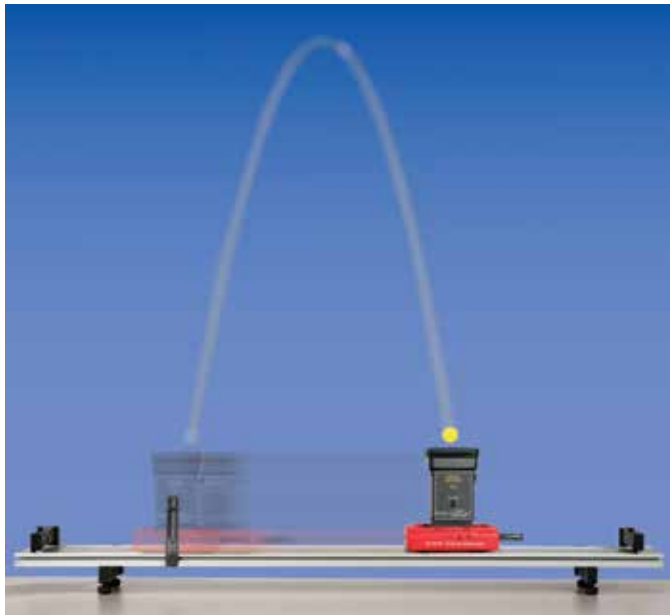

Ballistic Cart Accessory attaches to a Smart Cart and projects a ball as it travels along a track.

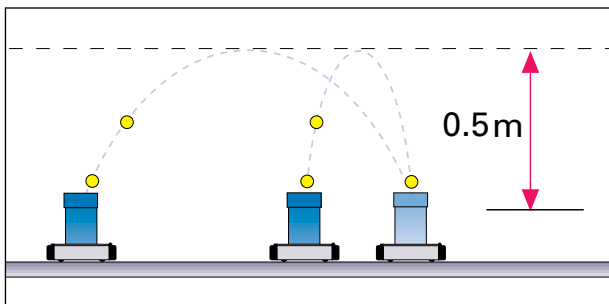

At slow or fast speeds, the results are the same.



Compatible with PASCO Classic Carts, PAScars, GOcars, and Smart Carts.

## Features

- ▶ **Photogate Ball Release:** PASCO's optical release does not affect cart motion or ball flight path, no matter what the speed of the cart.
- ▶ **Alignable Barrel:** The barrel has X and Y adjustments so perfect vertical projections can be produced every time, even on non-level surfaces.
- ▶ **Constant Velocity:** Mounts on the low-friction PASCO Dynamics Cart so horizontal velocity remains constant.
- ▶ **Strong Compression Spring:** Fires a colored nylon ball 0.5 meters or higher—impressive for demonstration purposes.

## Includes

- Ballistic Launcher
- Plastic Balls (2)
- Trigger Bracket
- 9 V Battery

## Order Information

Ballistic Cart Accessory .....ME-9486

## Required:

Dynamics System ..... p. 92-97

## Recommended:

Smart Cart (Red)..... ME-1240 p. 94

# Teach the difference between velocity and acceleration

## Visual Accelerometer

PS-2128

- ▶ Clearly demonstrates the difference between velocity and acceleration
- ▶ Shows both direction and magnitude of acceleration
- ▶ Acts as a sensor when connected to a computer (See page 36)

### How It Works

The Visual Accelerometer shows the magnitude and direction of acceleration in one dimension. Five green LEDs light in proportion to the acceleration to the right and five red LEDs light in proportion to the acceleration to the left. Because the Visual Accelerometer is mounted on the accelerating object, students see the acceleration without having to look away at a computer.

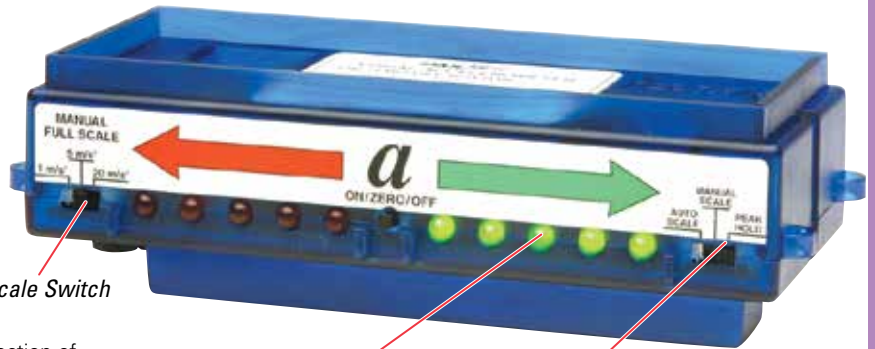

Scale Switch

Super Bright LEDs

Mode of Operation Switch



Push a cart up the incline and let it go back down. Students will expect the direction of the acceleration to change, depending on whether the cart is going up or down the incline. They are surprised that the red lights stay lit in the same direction.



The Visual Accelerometer can be used with the Smart Fan Accessory (ME-1242).

### Features

- ▶ **Super Bright LEDs:** Strong visual clues to both the magnitude and direction of the acceleration.
- ▶ **Portable:** Clearly shows magnitude and direction of acceleration with no cord attached.
- ▶ **Auto-Scale:** The auto-scale feature makes any acceleration between 0.2 and 20 m/s<sup>2</sup> a full-scale reading.
- ▶ **Peak-Hold Mode:** Freezes the lighted LEDs at the maximum acceleration so it can be viewed after the object stops.

### Specifications

**Three Manual Scales:** 1 m/s<sup>2</sup>, 5 m/s<sup>2</sup>, 20 m/s<sup>2</sup> full scale  
**Requires three AA batteries** for stand-alone operation (included)  
**Auto-off** after three hours

### Includes

- Visual Accelerometer
- Plastic M5 screws for attachment to a Dynamics Cart (2)
- Sensor Cable

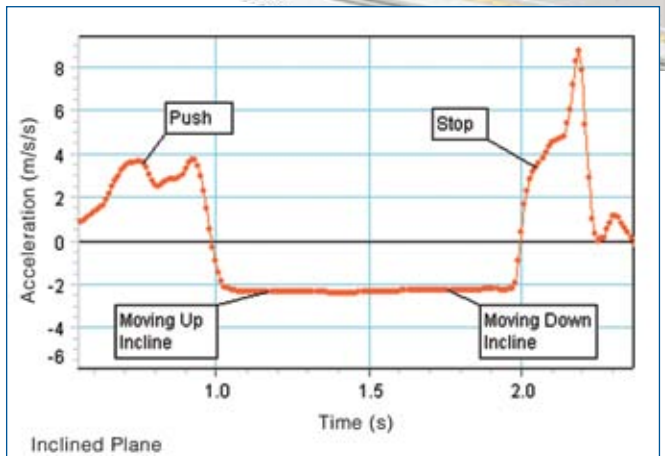

When connected to a computer, the Visual Accelerometer measures the acceleration as the cart is pushed by hand. The direction and magnitude of the acceleration is constant as the cart goes up and then goes down the incline.

### Order Information

PASPORT Visual Accelerometer..... PS-2128  
 Smart Fan Accessory..... ME-1242

## Cart Accessories

# Hooke's Law, Spring Potential Energy, and Work-Kinetic Energy Theorem all in one cart launcher.

## Spring Cart Launcher

ME-6843\*

- ▶ Affordable cart launcher
- ▶ Hooke's Law
- ▶ Spring potential energy

The Spring Cart Launcher provides an economical way to launch carts in a repeatable fashion. It can be used for Hooke's Law, collisions, and for Conservation of Energy. It fits into the bed of a Dynamics Cart or PAScar. To launch the cart, the plunger is pulled through the hole in the new endstop, compressing the spring, and then released. To add repeatability, a second endstop can be used with the supplied pin to hold the plunger at a specified compression position. Three different strength springs are provided with the Spring Cart Launcher. Use with or without probeware.

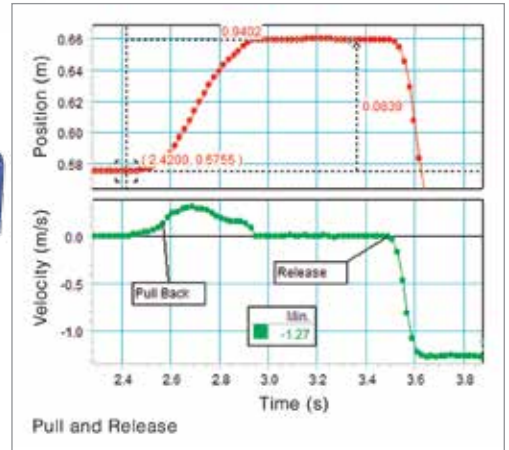

The spring potential energy is converted to kinetic energy. The Spring Cart Launcher rides in the cart, so nearly all the energy from the spring is transferred to the cart. The position of the cart (top) and the velocity of the cart (bottom) are measured using the Motion Sensor.

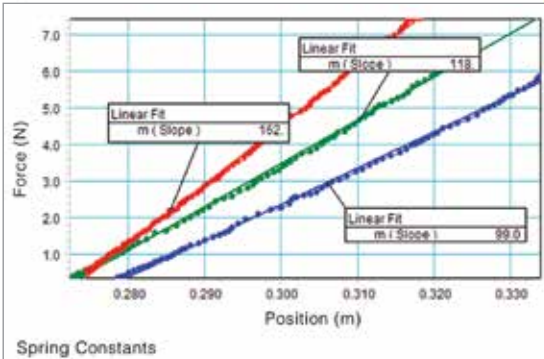

To perform the Hooke's Law experiment, the Spring Cart Launcher plunger is pulled with a Force Sensor (PS-2104), compressing the spring, while the displacement of the cart is measured with a Motion Sensor (PS-2103A). The slopes of the graphs of Force versus Position give the spring constants for the three different springs.

### Includes

- Spring Cart Launcher
- Trigger Pin
- Three Different Strength Springs



### Order Information

Spring Cart Launcher ..... ME-6843

Required:

Dynamics Track System ..... See pages 92-93

\*NOTE: Not compatible with the Smart Cart

Recommended:

End Stops (2) ..... ME-8971 p. 112

Replacement Springs ..... ME-6847  
(Three different strength springs, two each)

Compact Cart Mass ..... ME-6755 p. 112

## Friction Block

ME-9807



- ▶ Two types of material
- ▶ Vary surface area by using it flat or up on its side
- ▶ Hook for attaching a string to pull it
- ▶ Slot for a picket fence or flag for photogate timing

The wooden Friction Block has felt on two sides, so the frictional coefficients for felt or wood can be measured. It also fits into the dynamics cart tray so the cart can run on its wheels, or it can be turned upside down to run on the Friction Block, without changing the mass.

### Features

- ▶ **Dimensions:** 13 cm x 5 cm x 1.7 cm
- ▶ **Approximate Mass:** 110 g

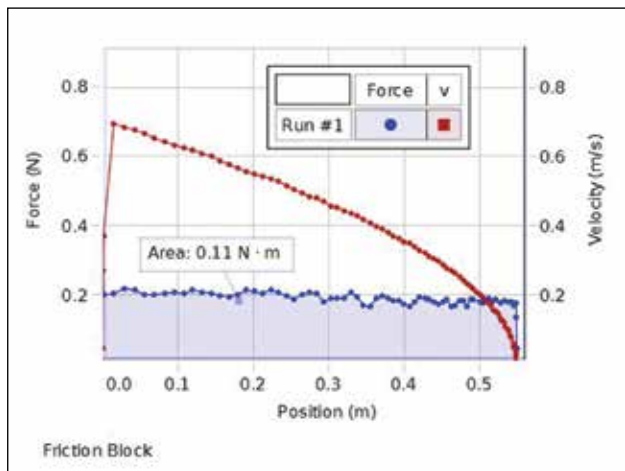

## Discover Friction Accessory

ME-8574

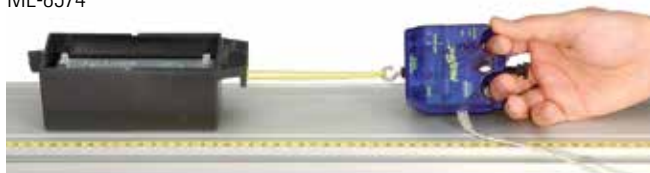

PASCO's Discover Friction Accessory is unlike any other friction set. The trays are designed to work effectively with PASCO carts and sensors. Using the four trays, students can discover such concepts as coefficient of friction, static friction, kinetic friction and the sliding friction equations. The two trays with identical plastic surfaces can be hooked together to explore the relationship between surface area and sliding frictional forces.

### Features

- ▶ **Easy Storage:** Friction trays are stackable
- ▶ **Versatile:** Students discover key friction concepts
- ▶ **Compatible:** Can be used with PASCO carts, masses, and Force Sensors

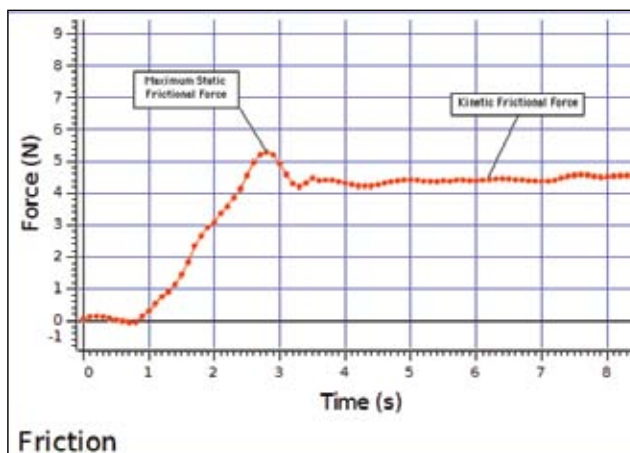

The peak of the graph represents the maximum static frictional force. Once the friction tray begins to move, the kinetic frictional force is evident on the graph.

### Includes

- Friction Tray - Felt
- Friction Tray - Cork
- Friction Tray - Plastic (2)



### Order Information

Discover Friction Accessory.....	ME-8574	
<i>Recommended:</i>		
Cart Mass.....	ME-6757A	p. 111
PAScar (red).....	ME-6933	p. 99
PAScar (blue).....	ME-6934	p. 99
Force Sensor.....	See pages 28-30	
Dynamics System.....	See pages 92-97	

### Order Information

Friction Block.....	ME-9807
<i>Shown in use with:</i>	
Dynamics Track System.....	See pages 92-97
End Stops (2).....	ME-8971 p. 112

# Dynamics Systems Accessories

## Force Bracket

ME-6622

The Force Bracket with bumpers mounts the PASCO Force Sensor directly to a dynamics track. It includes 5 collision attachments for the Force Sensor and conveniently stores each attachment on the bracket itself.

Using any of these attachments, the bracket serves as an excellent support or target for collision studies using the Force Sensor.



Wireless Force Acceleration Sensor (PS-3202) in cart collisions with fixed spring bumper on Force Bracket

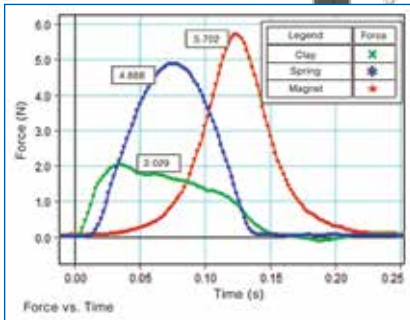

Force vs. time data for a clay, spring, and magnet

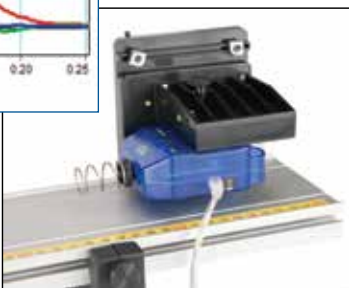

### Includes

- Spring Bumpers (2) (different spring constants)
- Magnetic Bumper (1)
- Rubber Bumper (1)
- Clay Cup for Inelastic Collisions (1) (clay included)
- #0 Phillips Head Screwdriver (to attach to Force Sensor)

### Order Information

Force Bracket..... ME-6622

## Bumper Accessory Set

ME-9884



This set of bumpers can be used with any PASCO Force Sensor to perform both elastic and inelastic collisions. The standard hook for each Force Sensor can be easily removed and replaced with any of these bumpers. Use a spring and a cup for elastic collisions. Combine two cups with clay to explore inelastic collisions.

### Includes

- Stiff Spring
- Empty Cup (2)
- Light Spring
- Modeling Clay



### Order Information

Bumper Accessory Kit..... ME-9884

## Magnetic Bumper Set

ME-9885A

This set of magnetic bumpers can be used with any PASCO Force Sensor to perform elastic collisions without any contact. The bumpers screw directly into the beam of the sensor. They can also be used with the Force Bracket.



### Includes

- Magnetic Bumper (2)



### Order Information

Magnetic Bumper Set..... ME-9885A

## Cart Adapter Accessory

ME-6743

The Cart Adapter Accessory allows the Motion Sensor and many other sensors to be mounted to a Dynamics Cart or a PAScar.



Mounting a Motion Sensor on a cart is ideal for the study of relative motion. The adjustment knob on the bracket allows the Motion Sensor to face any direction.

### Includes

- Two M5 thumb screws to attach to cart
- 1/4"-20 screw at center



### Order Information

Cart Adapter Accessory..... ME-6743

# Show that drag is proportional to speed and investigate critical damping.

## Magnetic Damping Accessory

ME-6828

The spring-and-car oscillation experiment shown here uses a Motion Sensor to measure the position and velocity of the cart. The Magnetic Damping Accessory induces eddy currents in the aluminum track, causing friction that is proportional to the velocity of the cart. Students can vary all of the parameters, including the amount of damping, track angle, cart mass, and spring constant.

**Motion Sensor**  
measures position and velocity of cart.

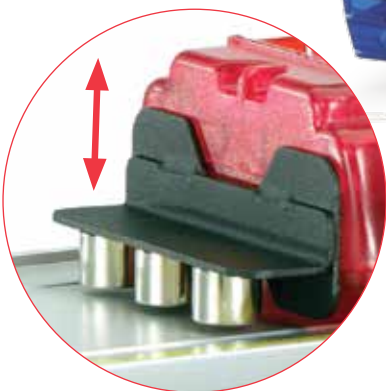

**Magnetic Damping**  
The steel bracket of the Magnetic Damping Accessory slides up and down to adjust the amount of damping.

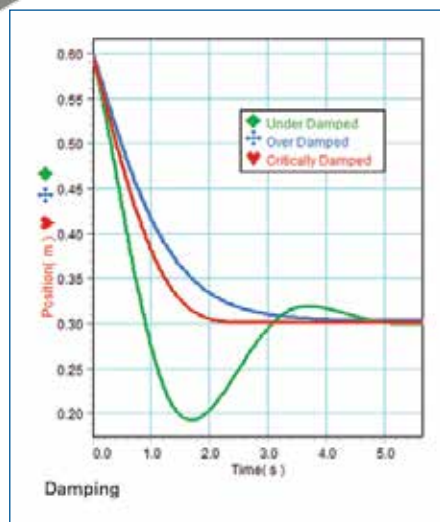

### Magnetic Damping using the new wireless Smart Cart

Measure the magnetic drag force directly with on-board force sensor in the Smart Cart. The Smart Cart also has an encoder that keeps track of its velocity. This plot of Force vs. Velocity shows the induced magnetic drag is proportional to the velocity.

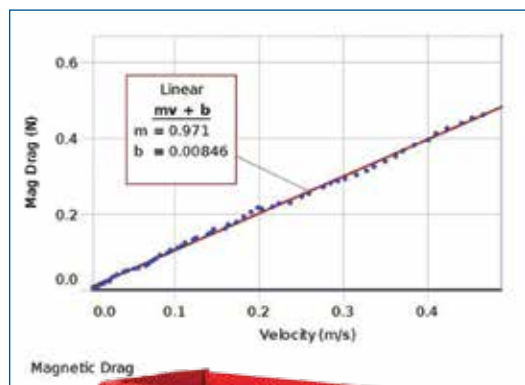

### Over-damped, Under-damped, Critically-damped

The cart is displaced from equilibrium and then released from rest. The green line shows a system that is under-damped, with the magnets far from the track. The cart is over-damped (blue line) when the magnets are very close to the track, and it takes over four seconds for the cart to reach its equilibrium position. When the cart is critically damped (red line) it reaches its equilibrium position in the minimum amount of time, which for this system is just over two seconds.

#### Includes

- Bracket
- Magnets
- Keeper



#### Order Information

Magnetic Damping Accessory.....	ME-6828	
<i>Equipment shown:</i>		
Basic PAScar/Metal Track System.....	ME-5702	p. 93
Dynamics Track Spring Set.....	ME-8999	p. 111
Motion Sensor.....	PS-2103A	p. 24
Wireless Smart Cart (Red) .....	ME-1240	p. 98
PASCO Capstone Software .....		pp. 18-20

## Mechanical Oscillator for Driven Harmonic Experiments

### Mechanical Oscillator/Driver

ME-8750

The Mechanical Oscillator/Driver delivers repeatable, low-frequency, high-force sinusoidal motion for harmonic motion experiments. Shown with the Smart Cart Standard Dynamics System (ME-5718), and it also works with other Dynamics Systems having a metal track.

#### Specifications

- ▶ **Sinusoidal Drive:** 12 VDC motor (frequency: 0.3-3 Hz, current: 0-0.3 A).
- ▶ **Adjustable Amplitude:** Up to 12 cm.
- ▶ **Mounts to Dynamics Track or Rod**
- ▶ **Photogate Mounting Holes**

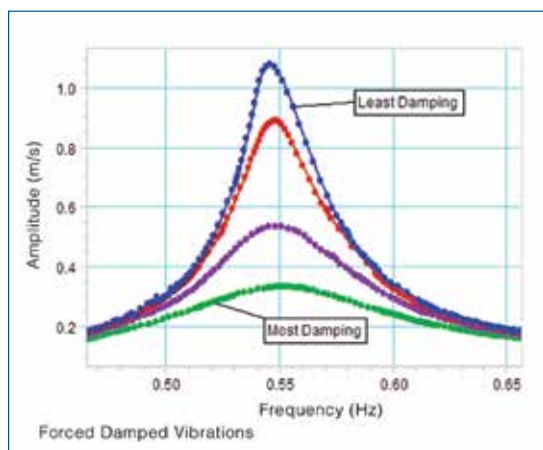

The velocity amplitude is plotted as a function of driving frequency. The four resonance curves show the effect of varying the strength of the magnetic damping.

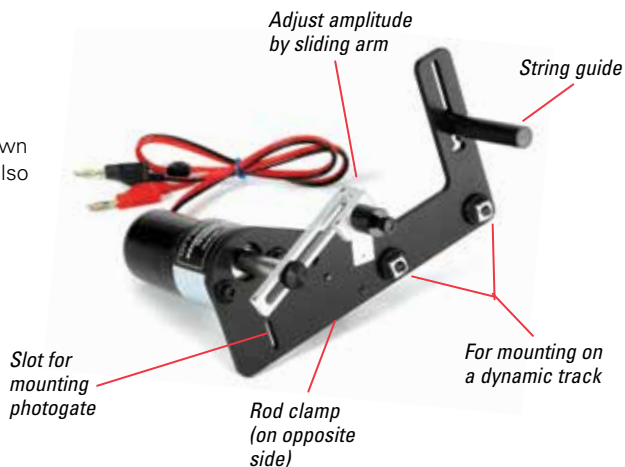
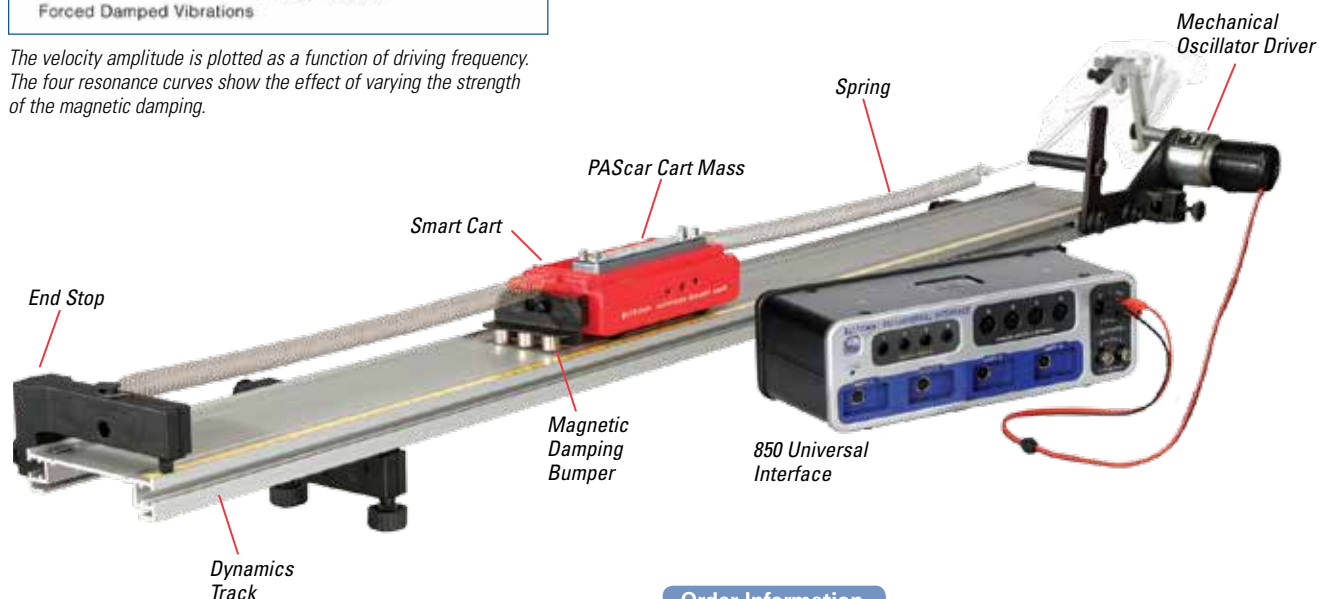

In this driven harmonic oscillation experiment, the amplitude and frequency data is provided by the Smart Cart.

The Mechanical/Oscillator Driver is driven by the output of the 850 Universal Interface. The 850 signal generator can be set to automatically ramp up the DC voltage to change the driving frequency over several minutes.

The damping is provided by the Magnetic Damping Bumper (ME-6828) which induces a current in the aluminum track. This gives a drag which is proportional to the velocity of the cart, thus making the differential equations solvable. The drag can be increased by moving the magnets closer to the track.

An interesting addition to this experiment is to ramp the driving frequency at a faster rate. This doesn't give the system time to react and the motion overshoots, causing the resonance curve to have a hysteresis.

#### Order Information

Mechanical Oscillator/Driver ..... ME-8750

Shown in use with:

Smart Cart Metal Track Standard System..... ME-5718

Magnetic Damping Bumper..... ME-6828

850 Universal Interface..... UI-5000

p. 93

p. 109

p. 12

## Compact Cart Mass

ME-6755

This 250 g mass allows students to change the mass of the Classic Cart or PAScar. It also fits on the Fan Cart (ME-9485).

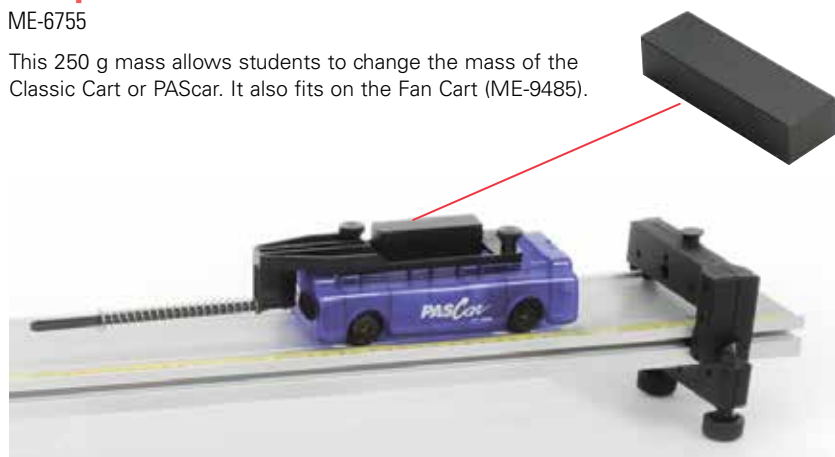

### Order Information

Compact Cart Mass.....ME-6755

## PAScar Cart Mass (set of 2)

ME-6757A



This 250 gram mass fits in any Dynamics Cart, the Motorized Cart (ME-9781), or the Discover Friction Accessory (ME-8574).

### Order Information

PAScar Cart Mass  
(set of 2).....ME-6757A

## Dynamics Track Spring Set

ME-8999



Includes 12 springs (1.6 cm diameter) with approximate spring constants of:

- 3.4 N/m (3 short and 3 long springs)
- 6.8 N/m (3 short and 3 long springs)

### Order Information

Dynamics Track  
Spring Set (12).....ME-8999

## Spring Set

ME-9803B



Includes eight identical springs: 8 cm long, 3.4 N/M spring constant.

### Order Information

Spring Set (8).....ME-9803B

## Cart Replacement Axles\* (4 pack)

ME-6957



*\*Not suitable for Smart Carts*

Although the ball bearings are designed for many years of use, the bearings can become damaged from dirt and other contaminants. The wheels and axles of the PAScar can be easily replaced by removing the lower section of the car and placing the new wheels in the chassis. A perfect tune-up for a PAScar or GOcar! The wheels of the Classic Carts can also be replaced with the same set of wheels. Contact PASCO's technical support for further assistance.

### Order Information

Cart Replacement Axles  
(4 pack).....ME-6957

## Braided Physics String

SE-8050

► 30-lb. test

This braided Dacron® string is tough, resists stretching, and won't unravel.

Withstands up to 133 Newtons of force (equivalent to 13.6 kg). Each roll provides 320 meters of string.



### Order Information

Braided Physics  
String.....SE-8050

## Super Pulley with Clamp

ME-9448B



*Shown with  
PAStrack*

Pulley clamps on the end of any Dynamics Track. Its height is fully adjustable to match height of string attached to a dynamics cart.

### Order Information

Super Pulley  
with Clamp .....ME-9448B

## Rubber Cord (30 meters)

ME-8986

For Elastic Bumper (ME-8998). Also fits Air Track Bumpers



### Order Information

Rubber Cord  
(Spool of 30 m).....ME-8986

## Use your Rotary Motion Sensor to track cart motion.

### Dynamics Track Mount

CI-6692

### Track String Adapter (RMS/IDS Kit)

ME-6569



The Dynamics Track Mount (CI-6692) is used to mount the Rotary Motion Sensor to the Dynamics Track, allowing it to act as a high resolution, bi-directional Smart Pulley.

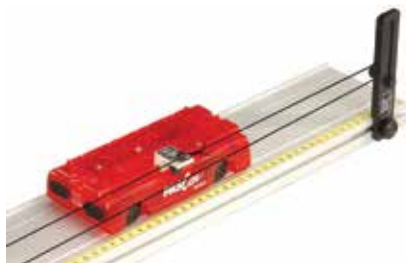

When used in conjunction with the Dynamics Track Mount (CI-6692), this unit allows a Rotary Motion Sensor to continuously monitor the Dynamics Cart position. A loop of string wraps around the Rotary Motion Sensor pulley and the ball-bearing pulley, and then it attaches to the cart via a special clip (included).

#### CI-6692 Includes

- Bracket



#### PS-2120A Includes

- Bracket with Pulley
- Cart String Clip
- Thread



#### Order Information

Dynamics Track Mount... CI-6692

Track String Adapter

(RMS/IDS Kit)..... ME-6569

*Rotary Motion Sensor for use with:*

ScienceWorkshop ..... CI-6538 p. 25

PASPORT ..... PS-2120A p. 25

### Track Rod Clamp

ME-9836



Shown with PASTrack

Track Rod Clamp fastens to the T-slot of a Dynamics Track and accepts 1/2" rod.

#### Order Information

Track Rod Clamp ..... ME-9836

### Adjustable Feet (2)

ME-8972



#### Order Information

Adjustable Feet (2).....ME-8972

### End Stops (2)

ME-8971



#### Order Information

End Stops (2).....ME-8971

### Angle Indicator

ME-9495A

The Angle Indicator fastens to the T-slot of a dynamics track. Hanging plumb-bob indicates angle to 1/2°.



#### Order Information

Angle Indicator.....ME-9495A

*Recommended:*

Projectile Launcher Plumb Bobs

(24 pack) .....ME-9868A

### Dynamics Systems Spares Kit

ME-9823

The Spares Kit contains many of the small parts that can get lost after classroom use. All parts are organized in a convenient case for easy storage.

#### Includes

- Cart Bumper Magnets (2)
- Velcro Hoop and Loop Bumpers (4)
- Dynamics Track Feet Screws (4)
- 1/4"-20 x 9/16" Tee Thumb Screws (4)
- 1/4"-20 x 9/16" Round Thumb Screws (6)
- 1/4"-20 x 3/8" Round Thumb Screws (6)
- 1/4"-20 x 7/32" Square Nuts (20)
- 1/4"-20 Nylon Thumb Nuts (6)
- 6-32 x 3/8" Nylon Thumb Screw (6)
- M5 x 0.8 x 20 mm Nylon Thumb Screw (4)
- 1/4"-20 x 3/8" Set Screws (4)
- Bumper Squares (8)
- Round Rubber Bumpers (4)



#### Order Information

Dynamics Systems

Spares Kit.....ME-9823

### Elastic Bumper

ME-8998

The Elastic Bumper protects the Motion Sensor from the carts, but doesn't interfere with the ultrasonic pulse.

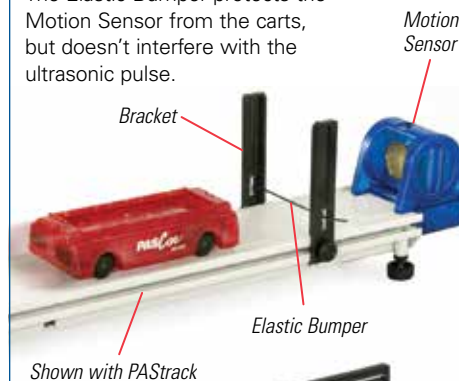

Shown with PASTrack

#### Includes

- Two pairs of brackets
- 10 meters of elastic material

#### Order Information

Elastic Bumper..... ME-8998

## Digital Photogate Timer System

ME-9403A

- ▶ High accuracy and resolution
- ▶ Four timing modes: gate, pulse, pendulum and manual stopwatch
- ▶ Built-in memory

PASCO digital photogates are used in thousands of physics labs throughout the world. They are rugged and simple to operate.

### Features

- ▶ **Built-in Photogate:** Timer serves as the base
- ▶ 0.1 ms Resolution and 0.05% Accuracy
- ▶ **Memory Function:** Allows two measurements in rapid succession, such as pre- and post-collision velocities
- ▶ **Easy Setup:** Turn it on and begin taking measurements
- ▶ **Portability or Plug-in:** Use four "C" cells (not included) or 9 V AC adapter (included)

### The Photogate Timers work with the following:

- ▶ Accessory Photogate
- ▶ Time-of-Flight Accessory
- ▶ Freefall Timer
- ▶ Laser Switch

### Specifications

**Modes:** Gate, pulse, pendulum, manual stopwatch  
**Resolution:** 0.1 ms (max time 19.9999 s)  
**Accuracy:** 0.05% of full range of the measured time  $\pm 1$  digit  
**Display:** 5-1/2 digit, 10 mm high LCD  
**Memory:** Preserves displayed time while new time is measured  
**Photogate:** 6.5 cm wide; fully adjustable swivel mount; LED trigger indicator; fall time <10 ns; spacial resolution <1 mm  
**Inputs:** Accessory Photogates, or TTL-compatible signals; one photogate jack and a 9-V AC adapter jack (or four "C" size batteries) on back panel



0.1 ms Resolution

Memory Record two times in rapid succession. The photogate will remember the first and the total of the two times.

Four Timing Modes



**Precision Photogates**  
 PASCO photogates are highly accurate timing devices. Each photogate has a high output, narrow angle infrared emitter and a narrow angle detector. The photogate signals:  
 – have a spatial resolution error of less than 1 mm  
 – have a rise time of less than 10  $\mu$ s  
 – are unaffected by normal ambient light

Accessory Photogate Can be purchased separately.

Digital Photogate Timer System Includes both the Photogate Timer and the Accessory Photogate.

ME-9215B Photogate Timer with Memory

Shown with the Freefall Timer Adapter ME-9207B.



### Order Information

Digital Photogate Timer System .....	ME-9403A
Photogate Timer with Memory .....	ME-9215B
Accessory Photogate .....	ME-9204B

## Timers

## The Most Versatile Stand-Alone Timer Available

## Smart Timer

ME-8930

- ▶ Portable timer for photogates and smart pulleys
- ▶ Measures time, speed and acceleration
- ▶ Counter for G-M Tubes
- ▶ Crystal-controlled 0.01% accuracy

**Measure Time:**

- ▶ One Gate: Returns time from leading edge to leading edge
- ▶ Fence: Returns 10 time values
- ▶ Two Gates: Returns time between two gates
- ▶ Pendulum: Measures pendulum period
- ▶ Stopwatch: Returns time between pressing Start/Stop button

**Measure Speed:**

- ▶ One Gate: Single object speed using picket fence
- ▶ Collision: Initial and final speeds for one or two carts
- ▶ Pulley: Angular speed

**Measure Acceleration:**

- ▶ One Gate: Direct measurement of acceleration using picket fence
- ▶ Linear Pulley: Acceleration of string
- ▶ Angular Pulley
- ▶ Two Gates: Object's average acceleration between two photogates

**Measure Counts:**

- ▶ Three timing intervals
- ▶ Manual mode counts until Stop is pressed
- ▶ Up to 5,000 counts/second
- ▶ Up to 9,999,999 total counts

**2-line, 16-character Alphanumeric LCD**

Top Line: Measurement Description; Bottom Line: Numerical Values

**It's as easy as 1-2-3.****1. Measurement**

Press this button to select the quantity to be measured: "Time," "Speed," "Accel," "Count" or "Test" will appear on the display.

**2. Mode**

Press this button to select the type of experimental setup. Each mode is shown in words on the display.

**3. Start/Stop**

Press Start. The Smart Timer "beeps," and waits for an event to occur. After the event, the Smart Timer displays a result.

**The ME-8930 Smart Timer works with all PASCO timing devices**

- ▶ Accessory Photogate
- ▶ Photogate/Pulley System
- ▶ Time-of-Flight Accessory
- ▶ Freefall Adapter
- ▶ Laser Switch
- ▶ G-M Tube

**Features**

- ▶ **Works with Two Photogates**
- ▶ **More than just a Timer:** Measures speed and acceleration as well as time.
- ▶ **Quick Setup:** Turn on the switch, plug in the photogates, and it's ready to use.
- ▶ **Portability or Plug-in:** The battery-operated (four "AA"s) Smart Timer can be used outside the classroom away from power outlets. It can also be operated on the 9 VAC adapter (included).
- ▶ **Calculation Lock-out Switch:** A switch inside the battery compartment disables the speed and acceleration modes. Timing modes are unaffected, and students are required to do their own calculations.

**Specifications****Resolution:** 100  $\mu$ s**Accuracy:** 0.01% of full range of the measured time**Display:** 2-line, 16-character, alphanumeric LCD**Inputs:** Two 1/4" stereo phone jacks on side panel—TTL compatible**Power Requirements:** Four "AA" batteries (not included) or AC adapter (9 VDC, 500 mA) included**Typical Experiments**

1. Acceleration Due to Gravity\*
  2. Newton's Second Law\*
  3. Conservation of Momentum in Collisions\*
  4. Rotational Inertia of a Disk & Ring\*
  5. Acceleration Down an Incline
  6. Simple Harmonic Oscillator
  7. Oscillations on an Incline
  8. Springs in Series and Parallel
  9. Projectile Motion Using Photogates
  10. Time-of-Flight and Initial Velocity
  11. Determining the Acceleration Due to Gravity
  12. Counting Radiation with the G-M Tube
- \*Experiments require accessories listed on pages 37-41.



To see the experiments, type the product number into the search box at [www.pasco.com](http://www.pasco.com) and download the manual.

**Two Photogate Ports****Durable Positive-click Buttons**

## The microprocessor-based PASCO Smart Timer is the most versatile way to make time, speed, acceleration, and count measurements.



**Speed of projectile— In Time:** Two Gates mode, determine the speed of a ball fired by a Projectile Launcher through two photogates.



**Speed of object through one gate— In Time:** One Gate mode, timing begins when the photogate beam is first blocked and continues until the beam is blocked again. Use the fence supplied with the Smart Timer.

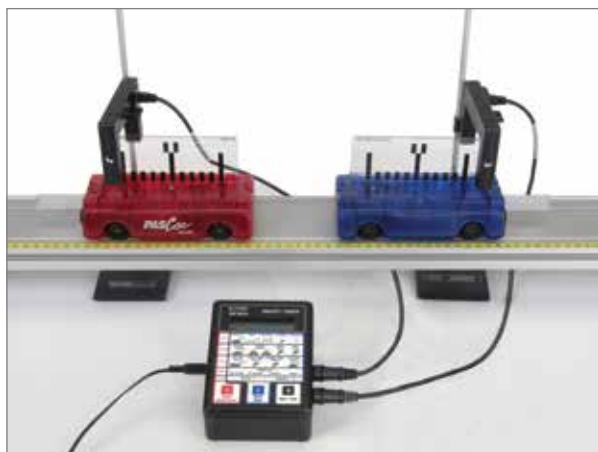

**Speed before and after collision— In Speed:** Collision mode, use two carts and two photogates with a single Smart Timer to measure initial and final speeds of both carts.



**Rotary motion— In Acceleration:** Linear Pulley mode, the Smart Timer measures the acceleration of the string over the Smart Pulley.

### Smart Timer (ME-8930) includes

- Smart Timer
- 9 VAC Adapter
- Picket Fences (2)
- Lab Manual

### Order Information

Smart Timer.....	ME-8930	
<i>Recommended:</i>		
Accessory Photogate.....	ME-9204B	p. 37
Smart Timer Fences (2).....	ME-8933	
Freefall Adapter .....	ME-9207B	p. 39
Photogate/Pulley System .....	ME-6838A	p. 37
Time-of-Flight Accessory .....	ME-6810A	p. 37
G-M Tube/Power Supply .....	SN-7927A	p. 39
Phone Jack		
Extender Cord.....	PI-8117	p. 39

### Smart Timer Photogate System

ME-8932

Comes with a full set of accessories for timing experiments. Attach the photogate to the Super Pulley to produce a "Smart Pulley."

### Smart Timer Photogate System (ME-8932) includes

1. Smart Timer
  2. Accessory Photogate (2)
  3. Super Pulley
  4. Picket Fences (2)
- 9 VAC Adapter and Lab Manual (not shown)



### Order Information

Smart Timer Photogate System.....ME-8932

## Timers

### Tape Timer

ME-9283

- ▶ Crystal-controlled
- ▶ Two frequencies (10 Hz and 40 Hz)
- ▶ Easy-to-read dots

#### The Method

Provides students with a visual demonstration of speed and acceleration. A moving object pulls a paper tape through the timer. The timer prints dots on the tape at equal time intervals. The result is a series of dots on the paper tape, representing the position of the object as a function of time.

From the dots on the tape, the distance traveled can be measured, and the average speed for each time interval can be calculated. Plotting position versus time enables students to determine the average speed. Plotting the average speed for each time interval versus time enables acceleration to be determined.

The paper tape can be attached to air track carts, dynamics carts, falling masses or other objects.

#### Features

- ▶ **Two crystal-controlled, calibrated frequencies:** (10 Hz and 40 Hz), accurate to 0.1%. The 40-Hz frequency is ideal for freefall experiments. The slower 10-Hz frequency is best for most dynamics track experiments.
- ▶ **Includes an internal 9-V battery, or use an optional external 9-V AC adapter/power supply:** A single battery can last for up to a year's worth of normal experiments.
- ▶ **Low mass, small-pin printing head:** Driven by short millisecond pulses, produces sharp, round dots without smearing.
- ▶ **Plain paper:** Print on 12.5 mm (1/2 inch) wide, plain paper supplied in 150-meter (500 feet) rolls.
- ▶ **Carbon paper discs:** Used for printing. The adjustable disc holder allows the printing point to be adjusted, giving a long life to the discs.
- ▶ **Rod clamp:** Allows the Tape Timer to be mounted on a standard lab stand rod so that the paper path is either parallel or perpendicular to the rod. Rod sizes between 13 mm (1/2 inch) and 9 mm (3/8 inch) are accommodated.



*Calculate the acceleration due to gravity by dropping a mass attached to the tape.*



*Use a Tape Timer, Dynamics Cart and Track to calculate acceleration down an inclined plane.*



#### Includes

- Roll of paper (1)
- Carbon paper discs
- Battery
- Manual (not shown)

#### Order Information

Tape Timer.....ME-9283  
**Recommended:**  
 9-V AC Adapter 120 V/500 mA...540-007  
 Tape Timer Supplies.....ME-9284  
*Includes five rolls of paper (each 150 m) and 10 carbon paper discs.*

### PASCO Stopwatch

ME-1234

- ▶ No alarm or clock
- ▶ Memory for stored event times
- ▶ Uses one AA battery
- ▶ Durable buttons

Are you tired of annoying stop-watch alarms going off all day? Are your students stuck in the clock mode and can't get their stop-watch back into the timing mode? Does your stopwatch stop working after changing that little watch battery? The PASCO Stopwatch solves all these problems!

This stopwatch was designed specifically for science timing. The modes of operation are intuitive and complete instructions are included. The buttons are built to last and it uses a single long-lasting AA battery, which is less expensive than a watch battery (and easier to install).



The PASCO Stopwatch fits comfortably in your hand.



The EVENT/RECALL button allows you to view the last time, in case students forget to write down their data. The EVENT/RECALL button is also used to store and recall up to nine event times. For example, record a series of events, such as times at which sandbags were dropped along the gym floor.

#### Specifications

- LED Display:** Visible indoors and outdoors
- Two Display Modes:** MM:SS.SS (01:25.34) or Decimal Sec (85.34 s)
- Precision:** 0.01 sec up to 59:59.99 (MM:SS.SS) or 3599.99 s  
Then 1 sec to 99:59:59 (HH:MM:SS) or 359999 s

**Max Number of Event Times:** Nine

**Auto-off:** After one hour idle

Can Be Used with a Lanyard (not included)

**Includes:** AA battery and instruction sheet

#### Order Information

PASCO Stopwatch.....ME-1234

## Hovercraft

ME-9838

- ▶ Students experience Newton's Laws
- ▶ Durable nylon skirt
- ▶ Rubber bumper
- ▶ Optional cordless air supply

Our Hovercraft follows the classic design, with a rugged nylon skirt attached around a 1.2 m wood platform. Students can easily ride on the Hovercraft to experience first-hand the kinematics of frictionless motion.

### How It Works

The nylon skirt is stretched around the wood platform and tightened using a steel wire. The center of the skirt is attached to the bottom of the wood platform. A custom rubber bumper is placed around the circumference of the wood platform. The bumper helps secure the skirt and also provides a soft cushion around the edge of the Hovercraft. A high-volume air source is used to force air through the platform and into the skirt. After sitting on the platform, the air source is turned on and the skirt inflates. Small holes in the skirt allow the air to escape, while providing the higher pressure needed to lift the rider. A built-in level helps students center their weight on the Hovercraft.

An optional Cordless Air Source (SE-8806) is also available (below). In addition, most leaf blowers provide enough air flow to support the Hovercraft.

The PASCO Hovercraft is capable of supporting up to 300 lbs and comes completely assembled.



Air source not included

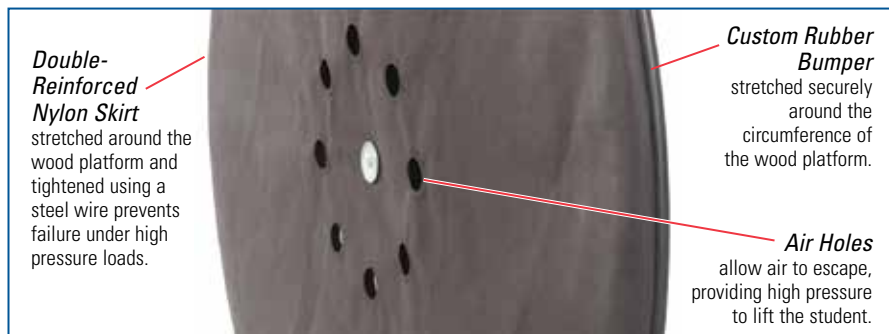

### Includes

- Wood platform (1.2 m diameter, 1.9 cm thick)
- Nylon skirt with mounting hardware
- Rubber bumper
- Liquid level
- Connection hose for air source



### Order Information

Hovercraft ..... ME-9838  
 Required:  
 Cordless Air Source ..... SE-8806

## Hover Puck

SE-7335B

- ▶ Hovers on a cushion of air
- ▶ Ideal for inertia activities

The Hover Puck glides on a self-generated cushion of air across any smooth surface, including low-pile carpet. The rubber bumper provides protection for the puck and other objects during collisions. Each puck includes four "AA" batteries.



### Specifications

**Diameter:** 18.5 cm  
**Height:** 6.0 cm

### Includes

- Hover Puck (Appearance may vary)
- Four "AA" Batteries

### Order Information

Hover Puck ..... SE-7335B  
**Recommended:**  
 Motion Sensor ..... PS-2103A p. 24  
 Motion Sensor II ..... CI-6742A p. 24

## Cordless Air Source

SE-8806



### Includes

- Rechargeable Battery
- Charging Adapter

**Note:** 220 V version **not** available.

### Order Information

Cordless  
 Air Source ..... SE-8806

## Air Track

## The PASCO Air Track

## PASCO Air Track

SF-9214

## Variable Output Air Supply

SF-9216

- ▶ Nearly frictionless linear motion
- ▶ Two meters long
- ▶ Complete accessories included

It's simple physics—a moving object will continue forever at a constant velocity unless it's acted on by an external force. To the physicist, Newton's First Law is second nature. Yet it's still fascinating to watch an air track glider moving endlessly back and forth on an air track.

It's even more fascinating for students, who are often seeing this simplest form of motion for the first time.

An air track glider provides the raw material for highly accurate investigations into the laws of motion. Add a timing system and investigate uniform motion, average and instantaneous velocities, uniform acceleration, elastic and inelastic collisions, impulse and change in momentum, conservation of momentum, conservation of energy and more. The data is precise and unambiguous. Frictional forces are negligible.

## Compared to other air tracks, the PASCO Air Track is:

- ▶ **Longer:** The 2-meter length provides more room for experimenting, yet it still fits on a standard lab table.
- ▶ **Straighter:** Straight to within 0.04 mm over its entire 2-meter length.
- ▶ **Quieter:** PASCO's Air Supply is exceptionally quiet. The air flow can be adjusted precisely for each experiment. Too little air causes friction; too much air causes energy loss due to glider "flutter."
- ▶ **Complete:** The PASCO Air Track comes with a complete set of accessories:
  - ▶ Two 170-gram gliders with soft bumpers. Glider collisions with hard bumpers can cause glider vibration, resulting in significant energy loss. Soft rubber band bumpers eliminate vibration and allow students to control the force and duration of each collision by varying the band tension.
  - ▶ Air Track Accessory Kit (all items shown on page 119)
  - ▶ Mounting hardware (two single-leg screws, two double-leg screws, one 4 mm wrench, one 5 mm wrench)
  - ▶ One single leg
  - ▶ One double leg with adjustable feet
  - ▶ Two fixed-end stops

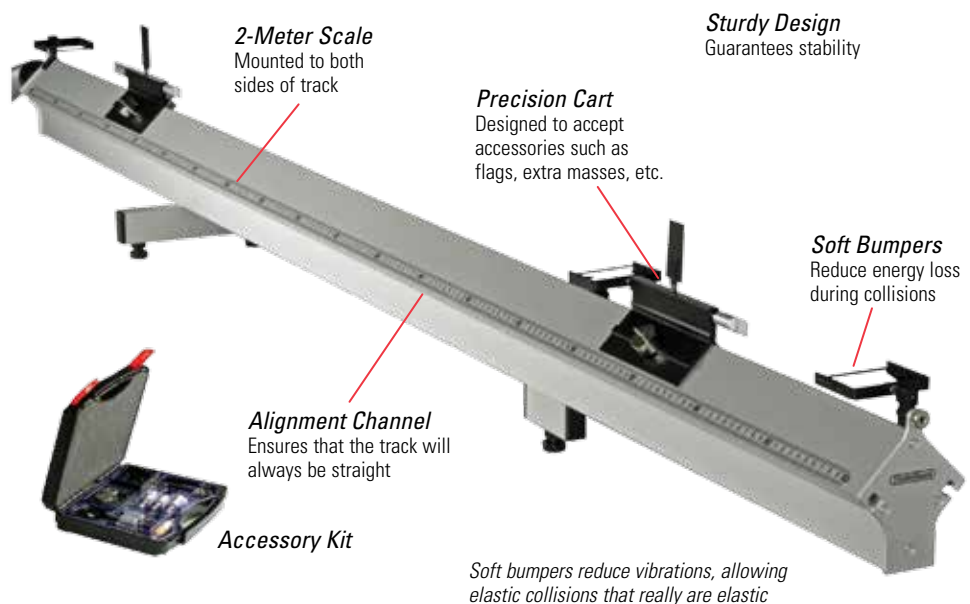

## Specifications

**Length:** 2 m (working distance 1.9 m)

**Base:** Three-point with bilateral leveling screws

**Millimeter Scales:** 2 meters long on each side

## Includes

- Gliders (2): 13 cm long; 170 g; with rubber band bumpers
- Glider Flags (2): 25 mm
- Glider Masses (4): 50 g
- Glider Bumper (3)
- Inelastic Collision Kit (1): Needle with wax-filled receptacle
- Constant Acceleration Kit: Ball-bearing pulley, glider hook, mass hanger (2 g) and five acceleration masses: two 1 g; one 2 g; one 5 g; one 10 g
- Storage Case

## Order Information

2.0 m Air Track..... SF-9214

*Required:*  
Variable Output Air Supply..... SF-9216

*Suggested:*  
Replacement Parts..... see page 119

## Air Track Accessory Kit

SF-9295



A set of accessories comes with every PASCO Air Track. All that's needed is a timing system. The pieces of the set may be ordered separately.

### Order Information

Accessory Kit– Air Track.....SF-9295  
*Recommended:*  
 Glider Kit–Air Track.....SF-9224  
 Air Supply Hose (2 m)–Air Track.....SF-9298  
 T-Adapter and Hose–Air Track.....SF-9217

## Variable Output Air Supply

SF-9216



The PASCO Air Supply is exceptionally quiet. Its variable output lets students match the air flow to the experiment.

A 2-meter hose is included. By adding the T-Adapter and Hose (SF-9217), the Air Supply can operate two PASCO Air Tracks at the same time.

**Note:** This Air Supply produces 36 cfm at 0.122 psi for use with the Precision Air Track SF-9214. If used with another track, the total area of the air flow holes must be  $\geq 2.6 \text{ cm}^2$ , or the supply may overheat.

### Order Information

Variable Output Air Supply.....SF-9216

## Rubber Cord (30 meters)

ME-8986

For Elastic Bumper (ME-8998)  
 Also fits Air Track Bumpers



### Order Information

Rubber Cord (30 m spool) .....ME-8986

## Air Track Accessories and Replacement Parts

The Air Track includes accessories for standard air track experiments, from simple acceleration to elastic and inelastic collisions. To add more advanced experiments, a variety of additional accessories are available.



### Included in the SF-9295 Kit

(Each item may be ordered separately.  
 The number in parentheses indicates how many of each item is included in the Accessory Kit.)

1. **Mass/Hanger Set– Air Track (1)**  
SF-6300
2. **Bumper with Holder– Air Track (3)**  
SF-6301
3. **Bumper Set– Air Track (3)**  
SF-6302
4. **Inelastic Collision Needle– Air Track (1)**  
SF-6303
5. **Wax Receptacle (1)**  
SF-6304
6. **Glider Hook (1)**  
SF-6305
7. **Glider Mass (4)**  
SF-6307
8. **Ball Bearing Pulley– Air Track (1)**  
SF-6308
9. **25 mm Flag (2)**  
SF-6311

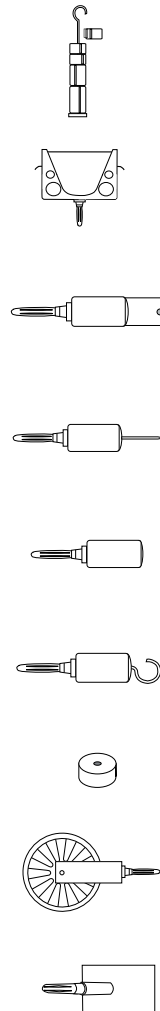

### Not included in the SF-9295 Kit

(Must be ordered separately.)

10. **Glider– Air Track**  
SF-6306
11. **Fixed End Stop– Air Track**  
SF-6313
12. **Adjustable End Stop– Air Track**  
SF-6309
13. **U-shaped Glider Flag**  
SF-6312
14. **Glider Kit– Air Track**  
(see photo at bottom)  
SF-9224  
(Includes one glider, two 50 g masses, bumper with holder, and bumper blade.)
- (The following two items are not pictured above and not included in the kit.)
15. **Air Supply Hose (2 m)– Air Track**  
SF-9298
16. **T-Adapter and Hose– Air Track**  
SF-9217  
(Allows two air tracks to be operated from one air supply.)

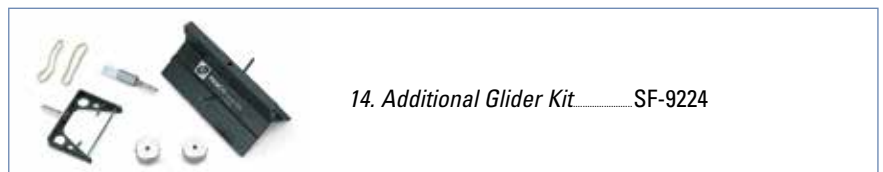
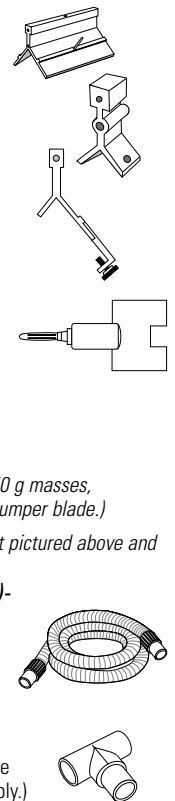

14. **Additional Glider Kit**.....SF-9224

# Roller Coaster

## Roller Coaster Complete System

ME-9812

- ▶ Quantitative studies of Energy Conservation
- ▶ Easy to change track configurations
- ▶ 3-car roller coaster

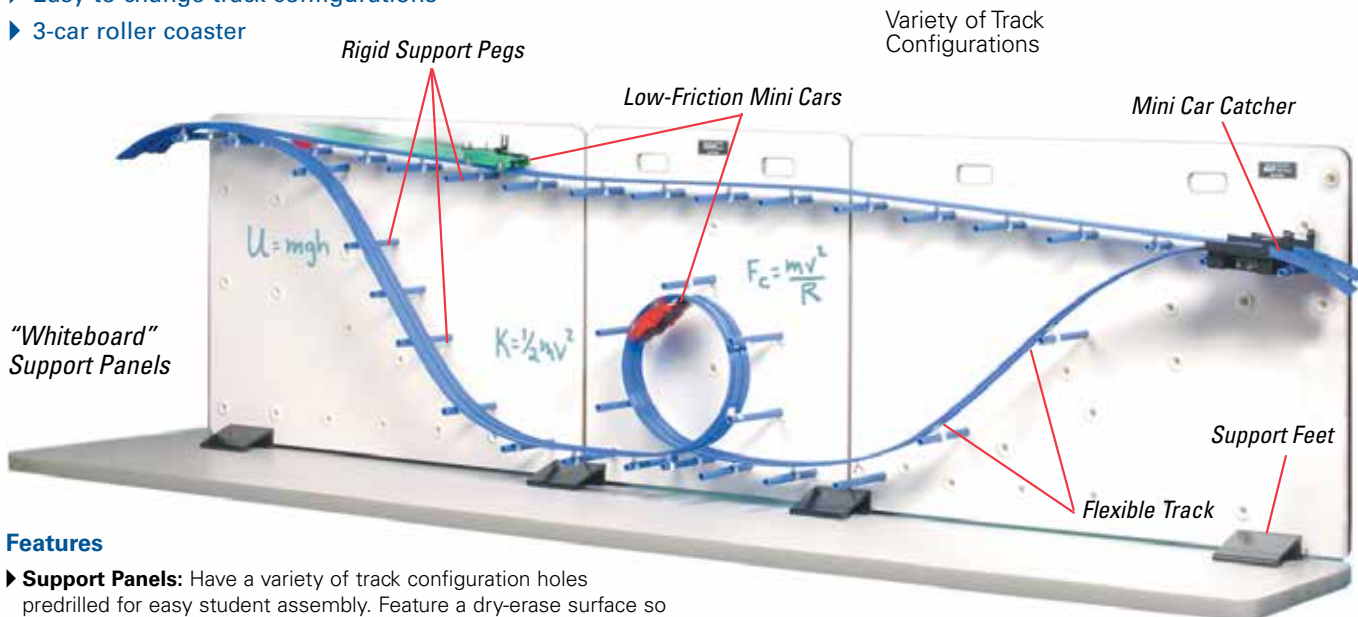

### Features

- ▶ **Support Panels:** Have a variety of track configuration holes predrilled for easy student assembly. Feature a dry-erase surface so calculations can be performed at the point of interest on the track.
- ▶ **Mini Cars:** Feature low-friction ball bearings and ABS construction to withstand repeated impacts. One red, one yellow, and one green Mini Car included. Each car includes a slot for a supplied photogate flag, cup/mass holder, and cup. The body of the car extends just far enough below the wheels to protect them, if the car leaves the track.
  - ▶ The Roller Coaster's Mini Cars are low friction, yet rugged; mass can be added to the cars on top or in the ballast position.
  - ▶ Bumpers mount on Mini Cars to allow rubber band or clay collisions. Also used to couple Mini Cars into a train.
- ▶ **Ballast Mass:** Can be added to mass tray of Mini Car or hidden under Mini Car to increase the energy without changing the car's outward appearance.
- ▶ **Flexible Track:** Guides carts on their path, yet is flexible enough to form loops and hills, or can be rolled out flat on a table. Easily attaches to the support pegs using the twist-on track clips. Long pegs allow two tracks side-by-side for comparison.
- ▶ **Probeware Compatible:** Threaded support pegs and Mini Car photogate flags allow photogates to be used at many positions around the track to measure velocity and acceleration.

### Roller Coaster Applications:

- ▶ **Conservation of Energy:** Release the Mini Car and measure its velocity and height at several points along the track. Use these values to calculate total energy of the Mini Car. Frictional losses are less than 5%.
- ▶ **Constant Acceleration:** Several straight inclined sections can be used to measure and demonstrate constantly accelerated motion.
- ▶ **Projectile Motion/Conservation of Energy:** Use the initial height of the Mini Car to determine its speed as it flies off the end of the track. Using this speed and height above the ground when it leaves the track, predict where the Mini Car will land.
- ▶ **Multi-car Train:** Mini Cars can be coupled to form a train and the velocity of each car can be measured with a photogate and a Smart Timer. The velocities are not the same.
- ▶ **Brachistochrone:** A Mini Car traveling between two points along a brachistochrone path takes less time compared to the straight line path.

### Includes

- Support panel (3 sections)
- Support feet (4)
- Flexible track (9.1 meters)
- Mini Cars (3)
- Support pegs for track (43)
- Photogate support pegs (4)
- Track clips (50)
- Mini Car catcher (2)
- Mini Car starter bracket (2)
- Mini Car collision accessory (3)
- Mini Car photogate flags (3)
- Water cup (3)
- Mini Car ballast mass (3)
- Photogate brackets (4)
- Track couplers (2)

### Order Information

Complete Roller Coaster..... ME-9812

#### Recommended:

Photogate Head .....	ME-9498A	p. 37
Photogate Bracket (2) .....	ME-9806	p. 97
Roller Coaster Spares Kit .....	ME-9815	
Mini Car Set .....	ME-9813	
Roller Coaster Track (9.1 meters) .....	ME-9814	
Smart Timer .....	ME-8930	p. 114
or Computer Interface .....		p. 10-11



## Design your own roller coaster with PASCO's Structures System

PASCO's Structures System allows students to design and build their own roller coaster for detailed studies of conservation of energy and centripetal force. The flexible track is perfect for building hills, valleys and even a loop! Car with low friction, ball-bearing wheels minimizes energy losses. Measure the speed of the car using photogates or a Motion Sensor.

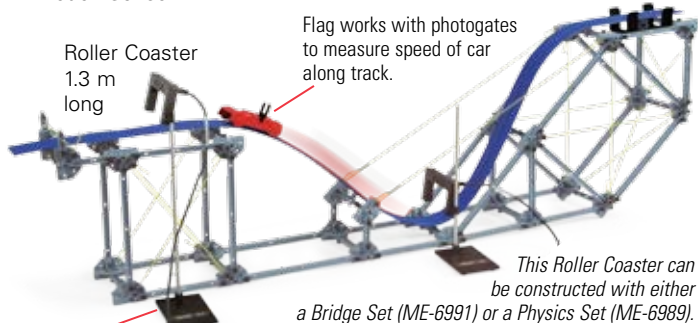

Position Accessory Photogate anywhere along the track to measure speed.

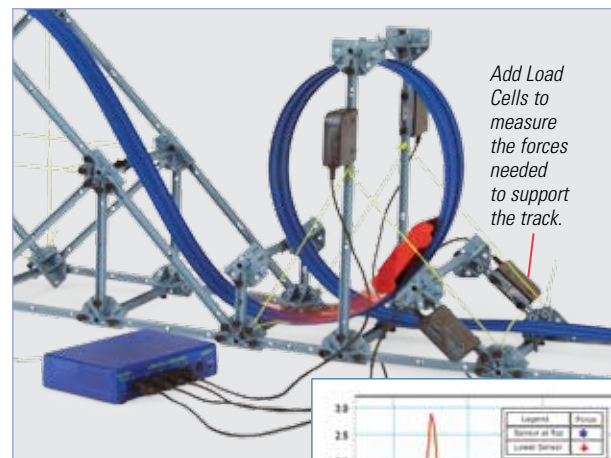

### Add a loop to your roller coaster

Investigate the effect of changing the size and shape.

Graph shows support forces exerted on the track as the car goes up and over the loop.

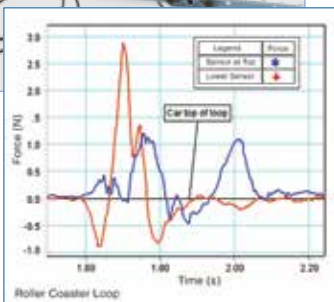

## Amusement Park Physics Kit

ME-9426A

- ▶ Extend your lab into the "real world"
- ▶ Complete kit for 15 students
- ▶ Developed in conjunction with AAPT\*

They might lose their notes. They might even lose their nerve. But in one day at an amusement park, students will also gain a real "gut-level" appreciation for Newton's Laws. Using this kit, students don't observe a dynamics cart. They are the dynamics cart. This is the only kit that is:

- ▶ Approved by the safety officers of major amusement parks across the USA.
- ▶ Student-tested in amusement parks by hundreds of schools.
- ▶ Teacher-tested in hundreds of Amusement Park Physics Workshops.
- ▶ Made with a metal coil spring for the Vertical Accelerometer (far more accurate than the commonly used rubber band).
- ▶ Supporting physics education (for each set sold, \$2.50 is donated to the AAPT).

\* American Association of Physics Teachers

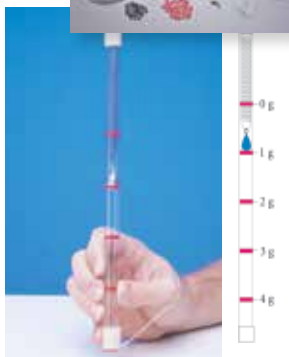

Photo courtesy of Paramount's Great America.

### Includes

- Brass Hanging Weights (19)
- Springs\*\*  $k = 3 \text{ N/m}$  (16)
- Plastic Tubing (2.5 m)
- Plastic Tubes, 30 cm long (16)
- Plastic Tube End Caps (32)
- Bumper Stickers (16)
- Horizontal Accelerometer
- Cards (16)
- Push Pins (5)
- No. 3 Paper Clips (17)
- Cotton String
- Metal Balls (60)
- Straws (16)
- Wire Ties
- Vinyl Tape
- Rubber Bands #117 (32)
- Rubber Bands #19 (6)
- Plastic Storage Bags (16)
- Instruction Manual

\*\*Additional accelerometer springs may be purchased separately. See order information below.



The Vertical Accelerometer: The stretch of the spring measures the vertical acceleration in "g's."

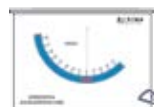

The Horizontal Accelerometer: The angle to which the BBs rise measures the horizontal acceleration. This accelerometer doubles as a sextant to measure distances by triangulation.

### Order Information

- Amusement Park Physics Kit (15 pack) ..... ME-9426A
- Recommended:
- Additional Accelerometer Springs (15 pack)..... ME-8734
- Scissors, pliers, masking tape, clear plastic tape

### Order Information

- Bridge Set ..... ME-6991 p. 142
- Large Structures Set ..... ME-7003 p. 144
- Shown in use with:
- Load Cell & Amplifier Set ..... PS-2199 p. 32
- Accessory Photogate ..... ME-9204B p. 37

# Gravity & Freefall

## Discover Freefall System

ME-9889

- ▶ Determine  $g$
- ▶ Investigate air resistance dependence on mass, volume, cross-sectional area

PASCO's Discover Freefall System can be used to drop almost any small object by attaching a small steel washer with a small adhesive pad (both are included in the system). Using an electric switch, timing is started automatically, just as the object is dropped. And the Time-of-Flight Pad stops timing when the object strikes it.

Students can investigate the effect of air resistance on acceleration. In addition, students can drop objects of the same size but different mass to study how object mass affects terminal velocity during freefall. The drop box has a magnetic mount for attaching to metal frames in ceilings.



This system can also accept the Target Accessory, ME-6854, to perform the shoot-the-target demonstration. See page 124.



- Includes**
- Drop box
  - Control cable
  - Control box
  - AC adapter
  - Time-of-Flight receptor pad
  - Timer Switch
  - Release washers (10)
  - Release labels for attaching washers to object (50)
  - Small nylon ball
  - Large plastic ball
  - Golf ball
  - Hollow golf ball
  - 1" steel ball
  - 5/8" steel ball

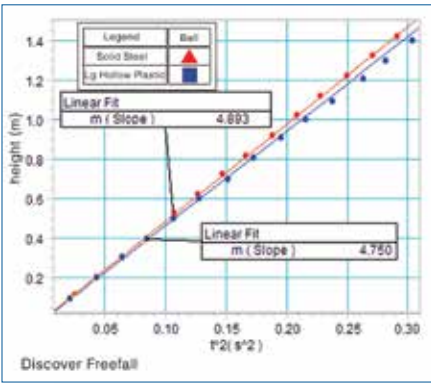

When the switch is pressed, the ball is dropped and the time of fall is measured for various balls. The graph shows height vs time-squared data for the 1 inch steel ball and the large hollow plastic ball. The slope of the line (equal to  $1/2 g$ ) gives an acceleration for the steel ball of  $9.79 \text{ m/s}^2$ . Note that the acceleration of the large hollow ball is considerably smaller, and that its data is not linear.

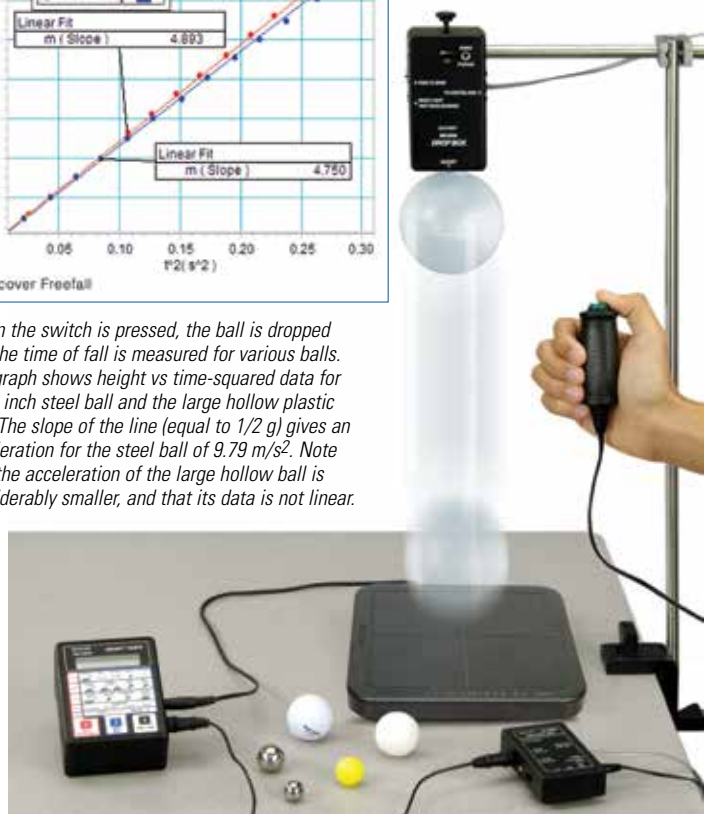

Shown in use with rods and clamps sold on pages 176-179. The Drop Box also has built-in magnets to fasten directly to the ceiling.

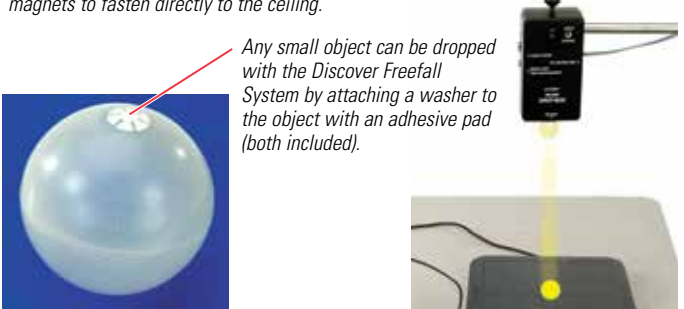

Any small object can be dropped with the Discover Freefall System by attaching a washer to the object with an adhesive pad (both included).

The Discover Freefall System also works with the 850, PASPORT or any ScienceWorkshop Interface. Shown here using a Digital Adapter.

**Order Information**

Discover Freefall System.....	ME-9889	
<b>Required:</b>		
Smart Timer.....	ME-8930	p. 114
850 Interface.....		pp. 12-13
or PASPORT Interface.....		p. 10-11
with Digital Adapter.....	PS-2159	p. 39
<b>Recommended:</b>		
Freefall Balls Accessory.....	ME-9890	p. 183
Rods and Clamps .....		p. 176-179

## Coin and Feather Tube

SE-9788

The “Coin and Feather” experiment is one of the best ways to dispel the “lighter objects fall more slowly” myth.

When the air inside the 75 cm tube is at atmospheric pressure, the feather (in this case a very visible piece of Styrofoam) falls significantly more slowly than the coin. The syringe vacuum pump (included) will bring the air inside the tube down to about 7% of atmospheric pressure, making the feather and the coin appear to drop at the same rate.

The Coin and Feather Tube includes a 3.8 cm diameter clear plastic tube with end caps, coin and “feather” (Styrofoam), and syringe vacuum pump.



### Order Information

Coin and Feather Tube ..... SE-9788

## Freefall Timer Adapter

ME-9207B

### How It Works

A steel ball is clamped into a spring-loaded release mechanism. At the instant the ball is released, the electronic timer automatically starts. The timer stops when the ball hits the receptor pad. With the accurate, high resolution timing and automatic start and stop, results are precise and repeatable.



### Includes

- Ball release mechanism with stereo phone plug and receptor pad
- Four steel balls (1.9 cm, 1.6 cm diameter)

Maximum distance of fall is 2 m.

Freefall Timer Adapter shown in use with the Smart Timer. The Smart Timer records the elapsed time from when the ball is dropped until the ball hits the receptor pad.

### Order Information

Freefall Timer Adapter ..... ME-9207B

#### Required:

Large Table Clamp .....	ME-9472	p. 179
Multi Clamp .....	ME-9507	p. 178
Rod (90 cm long) .....	ME-8738	p. 176
Photogate Timer .....	ME-9215B	p. 113
or Smart Timer .....	ME-8930	p. 114
or 850 Interface .....		pp. 12-13
or PASPORT Interface .....		pp. 10
with Digital Adapter .....	PS-2159	p. 39

## Constant Velocity Tubes (4)

SE-9072

This set is unusual because it includes a tube with both a bubble, a plastic ball and a metal ball, giving the students the added twist of having an object with a negative velocity and thus a negative slope on the graph. Students can predict where the ball and the bubble will meet.



Constant Velocity Tubes effectively introduce the relationship between graphs and motion. Students can use a meterstick and a stopwatch to plot the position of the bubble as a function of time as it moves up the tube. Each tube has an obstruction that serves as the initial position for the bubble. The slope and vertical intercept from the graph yield the equation of motion.



This set includes three tubes with varying viscosities and initial starting points plus one tube with both a bubble and two balls. The red one and the colorless one have the same viscosity.

Includes both a bubble and a metal ball!

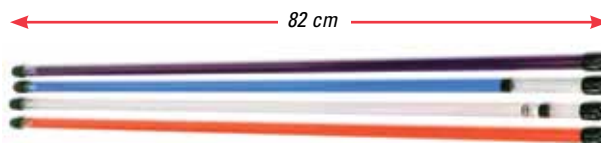

### Order Information

Constant Velocity Tubes (4) ..... SE-9072

#### Required:

Meter Stick (6 pack) ..... SE-8827  
PASCO Stopwatch ..... ME-1234

## Constant Speed Buggy

SE-8028A

Turn on the Constant Speed Buggy and watch it go. When it reaches a wall, it flips over and changes directions. This low-cost solution features flashing lights and a sporty appearance. Requires two “C” batteries that are not included. Actual product may vary from picture.



**WARNING**  
**CHOKING HAZARD**  
Small parts. Not for children under 3 years.

### Order Information

Constant Speed Buggy ..... SE-8028A

# Launchers

## Projectile Launcher

ME-6800

- ▶ Accurate
- ▶ Durable



Add optional Smart Gate to measure launch velocity.

Three Repeatable Launch Ranges Visible through viewing ports.

2.5 cm Nylon Balls



Loading Rod

Plumb Bob Indicates angle to 1/2°.

Stable Launcher Base Offers horizontal and variable angle launching positions.

## Unique Sights

### Shoot-the-Target

The "gun" is aimed directly at the target. Although the target "drops" the moment the projectile is fired, the ball still hits the target since the ball falls with the same acceleration.



Two bore sights simplify aiming the launcher.

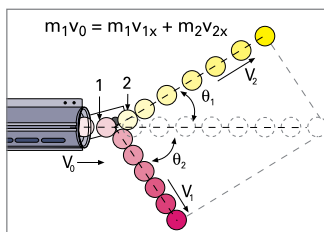
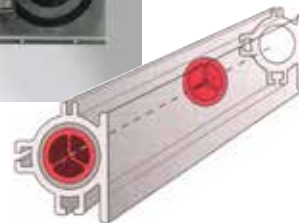

## 2-D Collisions

The 2-D Collision Accessory (included with all PASCO launchers) allows the study of **Conservation of Momentum** in two dimensions. Use the points of impact with the floor of each of the two balls to determine relative velocities and angles.

## Specifications

- Ranges:** 1.2, 3, 5 m
- Launch Angles:** 0 to +90°
- Launcher Length:** 21 cm

## Features

- ▶ **Fixed Firing Height at Any Launch Angle:** Firing height of ball is same for any launch angle.
- ▶ **Unique Piston Design:** Minimizes projectile spin to ensure repeatability of impact position.

## Includes

- Launcher with Base
- Projectile Balls
- Loading Rod
- Safety Glasses
- 2-D Collision Accessory
- Manual

## Order Information

Projectile Launcher .....	ME-6800	
<i>Shown in use with:</i>		
Shoot-The-Target System .....	ME-6853	p. 127
Photogate Mounting Bracket .....	ME-6821A	p. 129
Smart Gate .....	PS-2180	p. 36
<i>Recommended:</i>		
Time-of-Flight Accessory .....	ME-6810A	p. 129
Large C-Clamp (6 pack) .....	SE-7285	p. 179
Plumb Bobs (10 pack) .....	SE-8728	p. 129

## Launcher Spares Kit

ME-6802

### Includes

- Loading Rod (10)
- 2-D Collision Accessory (2)
- Plastic Balls (10 pack)
- Sights (5 pack)
- Angle Indicator
- Plumb Bobs (24 pack)
- Thumbscrew to attach launcher to base (10)



### Order Information

Launcher Spares Kit..... ME-6802

## Mini Launcher

ME-6825B

- ▶ Ideal for tabletop projectile experiments
- ▶ Fires at downward angles
- ▶ Low cost

*New bracket features include:*

- ▶ Magnetic ball storage
- ▶ New plunger storage
- ▶ Shooting positions now labeled

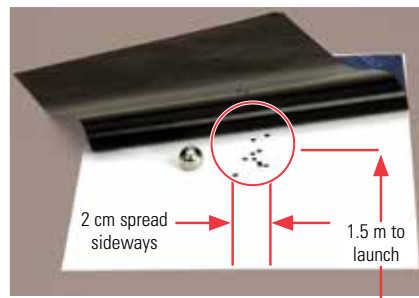
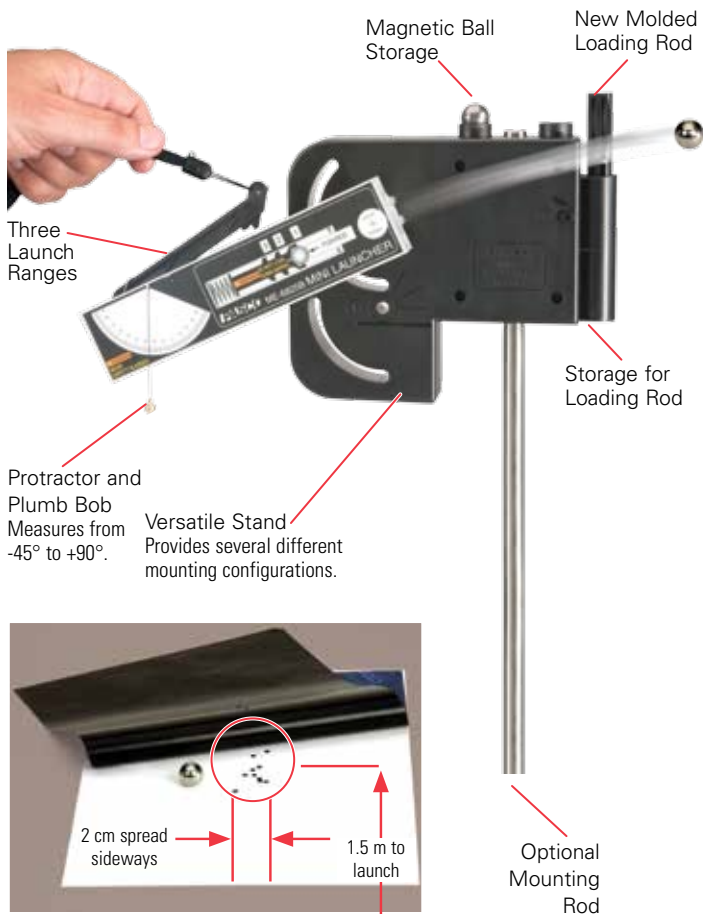

**Typical pattern for Mini Launcher –**  
Ball was launched 10 times off 1m high table at 30° angle. All 10 shots landed within 5 cm diameter circle.

## 2-D Collision



*Unique stand design allows ball to be launched from tabletop height. The ball lands on the table at the same height from which it was launched.*

*Magnetic Piston holds ball in place for launching at downward angles.*

### Specifications

- Range:** 0.5, 1, 2 m
- Launch Angle:** 0 to +90° and 0 to -45°
- Launcher Length:** 18 cm

### Includes

- Launcher Base
- Loading Rod
- 2-D Collision Accessory
- Projectile Balls
- Safety Glasses
- Manual

### Order Information

Mini Launcher .....	ME-6825B	
<i>Recommended:</i>		
Photogate Mounting Bracket .....	ME-6821A	p. 129
Smart Gate .....	PS-2180	p. 36
Time-of-Flight Accessory .....	ME-6810A	p. 129
Clamps .....		p. 179
Steel Rod .....	ME-8736	p. 176
Plumb Bobs (10) .....	SE-8728	p. 129
Carbon Paper (100 Sheets) .....	SE-8693	p. 126
Metric Measuring Tape .....	SE-8712A	p. 182

## Mini Launcher Spares Kit

ME-6824

### Includes

- Loading Rod (10)
- 2-D Collision Accessory (2)
- Steel Balls (10 pack)
- Angle Indicator
- Plumb Bobs (24 pack)
- Thumbscrew to attach launcher to base (10)



### Order Information

Mini Launcher Spares Kit.....ME-6824

## Launchers

### Projectile Launcher Smart Gate System

ME-6798

- ▶ Vary height.
- ▶ Vary angle.
- ▶ Vary launch speed.
- ▶ Measure accurately with Smart Gate.

With this combination, your students can study projectile motion and measure the initial speed with one economical Smart Gate since it has two photogate beams built in. The Mini Launcher and Smart Gate make the setup simple: Just clamp the launcher to the table and slide the Smart Gate on. All the components needed are included, even the rod and clamp.

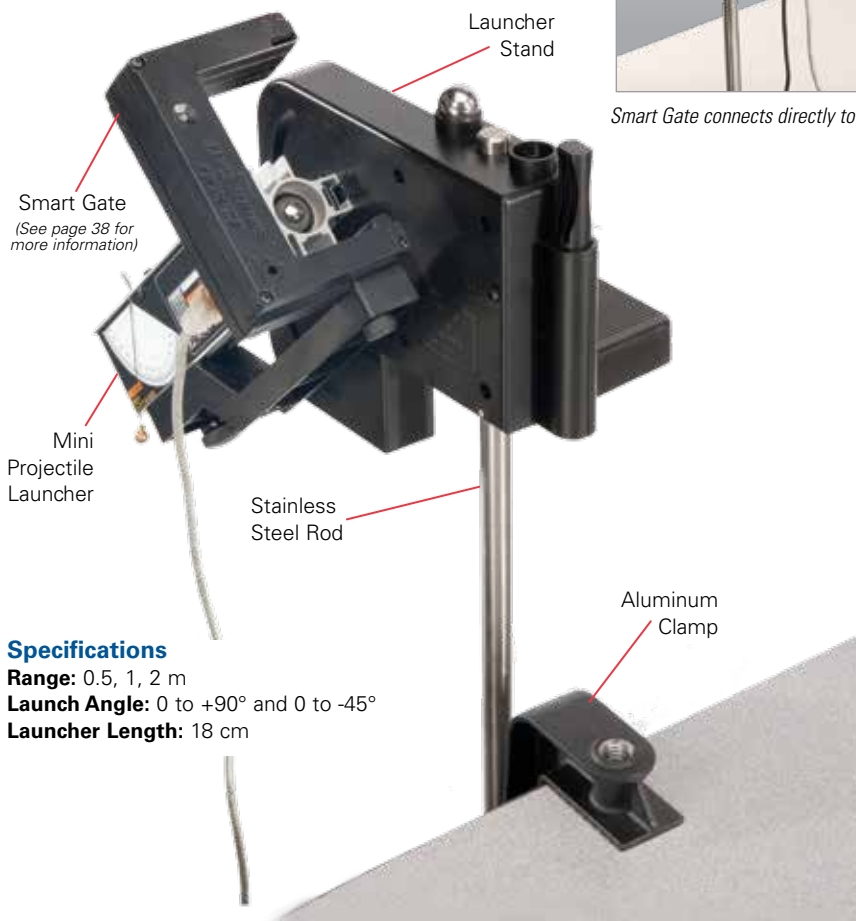

#### Specifications

**Range:** 0.5, 1, 2 m

**Launch Angle:** 0 to +90° and 0 to -45°

**Launcher Length:** 18 cm

#### Add optional Time-of-Flight



*Daisy-chain Time-of-Flight to Smart Gate*

Smart Gate connects directly to a PASPORT interface.

#### Includes

- Smart Gate with mounting bracket
- Launcher with Mounting Stand
- Steel balls (2) with loading rod
- 2-D collision Accessory
- Aluminum Table Clamp
- 45 cm Stainless Steel Rod



#### Order Information

Projectile Launcher  
Smart Gate System.....ME-6798

*Shown in use with:*  
Time-of-Flight  
Accessory .....ME-6810A p. 129

*Required:*  
PASPORT Interface

### Carbon Paper (100 sheets)

SE-8693

For marking the position of the ball.

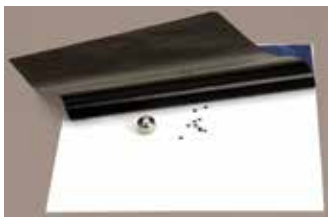

#### Order Information

Carbon Paper (100 sheets).....SE-8693

### Time-of-Flight Accessory

ME-6810A

- ▶ For use with all PASCO launchers

#### Includes

- Time-of-Flight Accessory
- Instruction Manual
- Experiment Guide

#### Order Information

Time-of-Flight Accessory .....ME-6810A



## Shoot-the-Target

ME-6853

- ▶ Demonstrate independence of  $x$ - and  $y$ -motion
- ▶ For use with all launchers

The PASCO Shoot-the-Target Accessory, in combination with a projectile launcher, demonstrates that acceleration is constant for all objects in free-fall, regardless of initial velocity. A target is initially suspended near the ceiling, and a projectile launcher is aimed directly at it. As soon as the projectile is shot from the launcher, the target is released. The projectile hits the target as it falls, proving that both objects accelerate downward at the same rate.

Before it falls, the target is attached to the drop box by a permanent magnet so it can hang indefinitely, even when the drop box is not powered. A photogate detects the projectile as it leaves the launcher and triggers the drop box. The drop box releases the target by driving a current through a coil that cancels the field of the permanent magnet.

*The "gun" is aimed directly at the target. Although the target "drops" the moment the projectile is fired, the ball still hits the target since the ball falls with the same acceleration.*

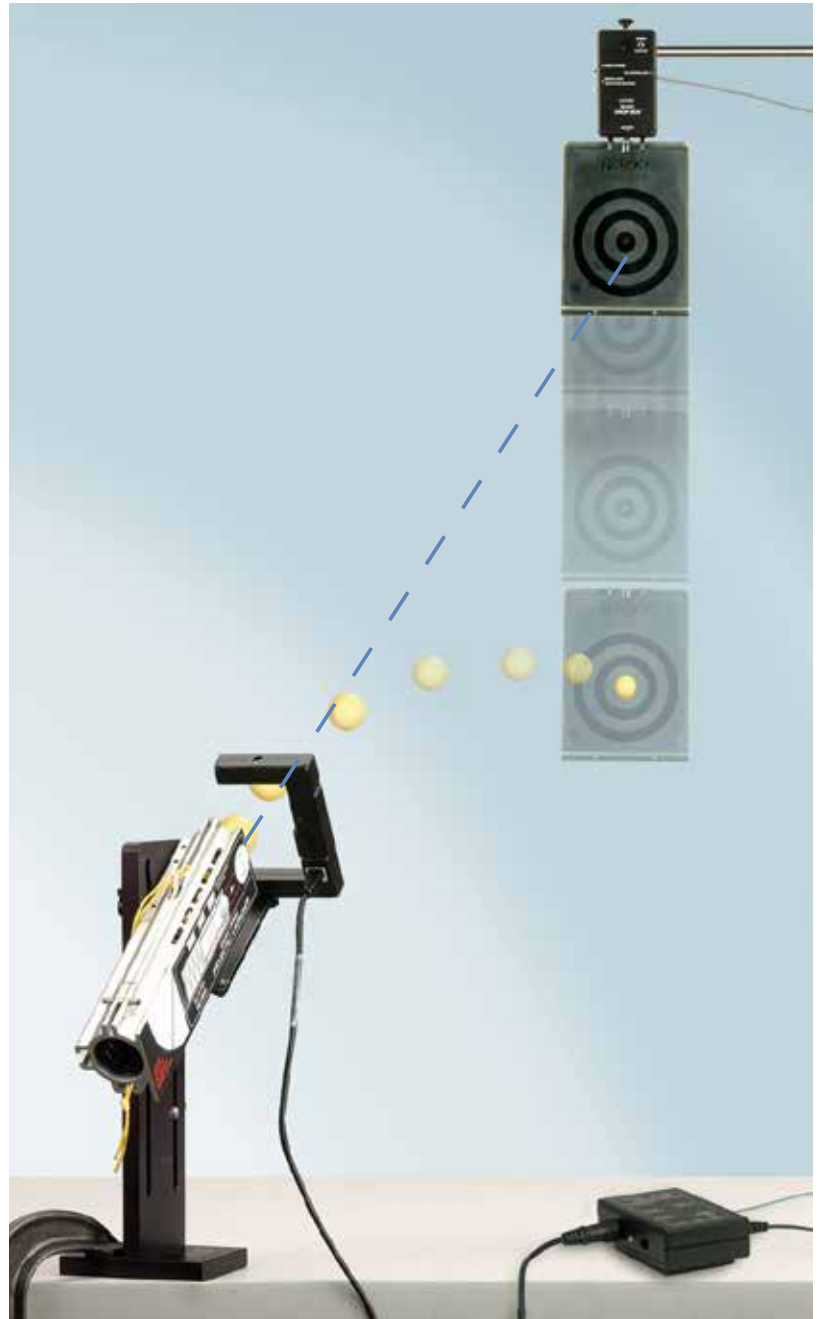

### Includes

- Drop Box & Control Box
- Control Cable
- High Impact Plastic Target (75 cm x 20 cm) ME-6852
- Photogate Head & Bracket
- AC Adapter (9 VDC, 500 mA)



### Order Information

Shoot-the-Target System.....ME-6853

*Recommended:*

Short-Range Launcher.....ME-6800

Mini Launcher .....ME-6825A

p. 124

p. 125

# Launcher Accessories

## Drop Shoot Accessory

ME-9859

- ▶ Simultaneously drops one ball and launches a second ball horizontally
- ▶ Prove the independence of  $x$ - and  $y$ -motion
- ▶ Mounts on PASCO projectile launchers (short- and long-range)

The Drop Shoot Accessory is an easy-to-use tool that helps students better understand the independence between the horizontal and vertical motion of a projectile. Connect the accessory to either the short or long range projectile launchers, hang one ball from the magnet and fire away. The fired ball strikes the hanging ball, causing one ball to shoot horizontally at the same instant the other ball falls straight down. Both balls hit the ground at the same time, regardless of the fired projectile's muzzle velocity, provided the Projectile Launcher is level. This device also provides an interesting demonstration of Conservation of Momentum in collisions.

When the (included) hollow steel ball is used, the two balls are both fired horizontally at two different speeds. A Photogate and Time-of-Flight Accessory can also be used to directly measure time of flight.



*Either the solid steel ball or hollow steel ball is hung by a magnet.*

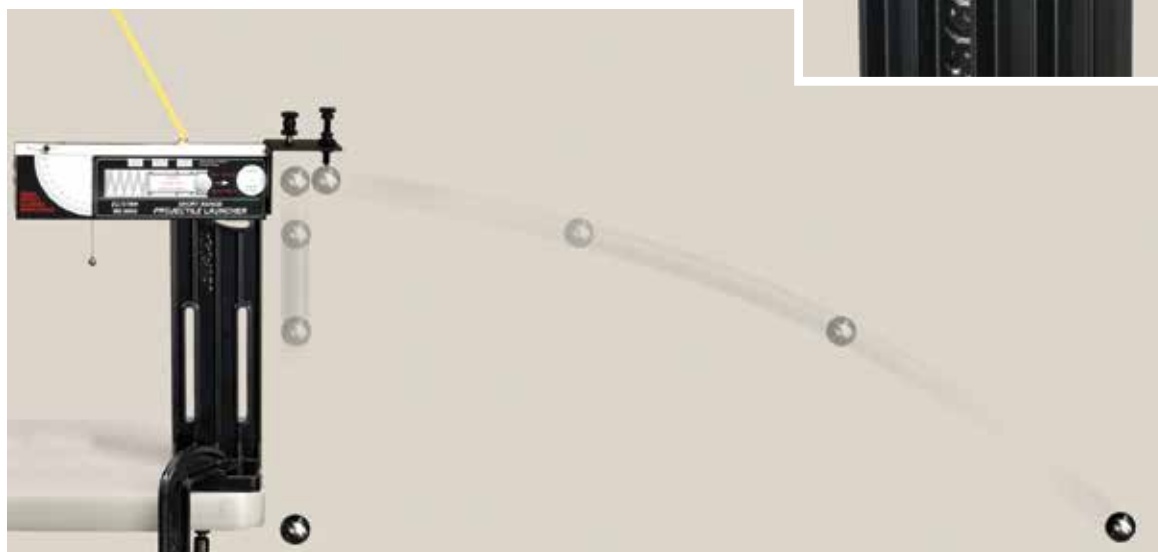

*When the solid ball hits the hanging solid ball, the hanging ball shoots out horizontally, while the ball shot out of the launcher drops straight down.*



### Includes

- Drop Shoot Bracket
- 2.5 cm Steel Balls (2)
- 2.5 cm Hollow Steel Ball
- Mounting Hardware
- Loading Rod

### Order Information

Drop Shoot Accessory.....ME-9859

*Required:*

Projectile Launcher.....ME-6800

p. 124

## Time-of-Flight Accessory

ME-6810A

▶ For use with all PASCO launchers

When the projectile is launched, the photogate mounted on the launcher starts timing.



When the projectile hits the receptor pad on the Time-of-Flight Accessory, an electric signal is sent to stop timing.

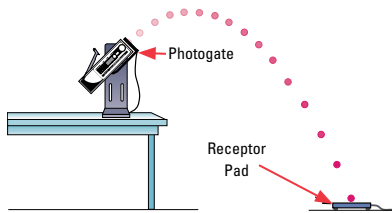

### Includes

- Time-of-Flight Accessory
- Instruction Manual
- Experiment Guide

### Order Information

Time-of-Flight Accessory ..... ME-6810A

## Photogate Mounting Bracket

ME-6821A



Mount one or two photogates on any Projectile Launcher. Compatible with Photogate Heads below.



### Order Information

Photogate Mounting Bracket ..... ME-6821A  
 Photogate Head ..... ME-9498A p. 37  
 Accessory Photogate ..... ME-9204B p. 37

## Small Steel Balls (10 pack)

ME-9872

These 1.6 cm diameter steel balls are used with the Mini Launcher (ME-6825).



**WARNING**  
**CHOKING HAZARD**  
 Contains small balls. Not for children under 3 years.

### Order Information

Small Steel Balls (10 pack) ..... ME-9872

## Steel Balls (4 pack)

ME-9864

Purchase this 4 pack of 2.5 cm diameter balls for use with PASCO Short or Long-Range Projectile Launchers (ME-6800 or ME-6801).



**WARNING**  
**CHOKING HAZARD**  
 Contains small balls. Not for children under 3 years.

### Order Information

Steel Balls (4 pack) ..... ME-9864

## Plastic Balls

ME-6822

Extra brightly colored balls are available for the Projectile Launcher. Diameter is 2.5 cm (1 in.).



**WARNING**  
**CHOKING HAZARD**  
 Contains small balls. Not for children under 3 years.

### Order Information

Plastic Balls (10 pack) ..... ME-6822

## Spherical Mass Set

ME-8968

This set includes four balls with a diameter of 2.5 cm each, but features various masses, including a hollow steel ball, solid steel ball, plastic ball and aluminum ball.



**WARNING**  
**CHOKING HAZARD**  
 Contains small balls. Not for children under 3 years.

### Order Information

Spherical Mass Set ..... ME-8968

## Projectile Launcher Sights (5 pack)

ME-9865

Purchase this 5 pack of aiming sights as a replacement for the Short-Range or Long-Range Projectile Launchers.



### Order Information

Projectile Launcher Sights (5 pack) ..... ME-9865

## Projectile Launcher Plumb Bobs (24 pack)

ME-9868A

Use this kit to make 24 brass plumb bobs to replace lost or broken parts from any of PASCO's projectile launchers.



### Order Information

Projectile Launcher Plumb Bobs (24 pack) ..... ME-9868A

## "C" Clamps

SE-7285

These rugged clamps are perfect for attaching a variety of objects to a table. Size 10 cm (4 inch).



### Order Information

"C" Clamp (6 pack) ..... SE-7285

## Plumb Bobs (10 pack)

SE-8728

### Order Information

Plumb Bobs (10 pack) ..... SE-8728



## Carbon Paper (100 sheets)

SE-8693



For marking the position of the ball.

### Order Information

Carbon Paper (100 sheets) ..... SE-8693

## Ballistics

## Ballistic Pendulum

ME-6830

- ▶ Extremely accurate—  $\pm 2.5\%$  of predicted values
- ▶ Both elastic and inelastic experiments
- ▶ Projectile launcher experiments
- ▶ Now includes ME-6800 bracket!

This classic physics experiment combines the laws of Conservation of Momentum and Conservation of Energy to determine the muzzle velocity of the projectile. Only simple mass and distance measurements are required to make this determination.

## How It Works

A projectile is fired into a pendulum, causing it to rise.

Using the projectile mass, the pendulum mass, and the rise in pendulum height, students can calculate the gravitational potential energy of the system.

Since the potential energy is equal to the pendulum's kinetic energy at the lowest point, students can calculate the speed of the pendulum at impact.

Applying the Law of Conservation of Momentum, the projectile's speed is easily calculated.

*An additional mounting bracket is included to perform the full range of projectile launcher experiments.*



Already own a PASCO Projectile Launcher?

The base and pendulum assembly can be purchased separately.

See Ballistic Pendulum (No Launcher) in the order block for more information.



## Unique Angle Measurement Design

Easily measures pendulum angle to  $0.5^\circ$ .  
Low friction gives repeatable results.

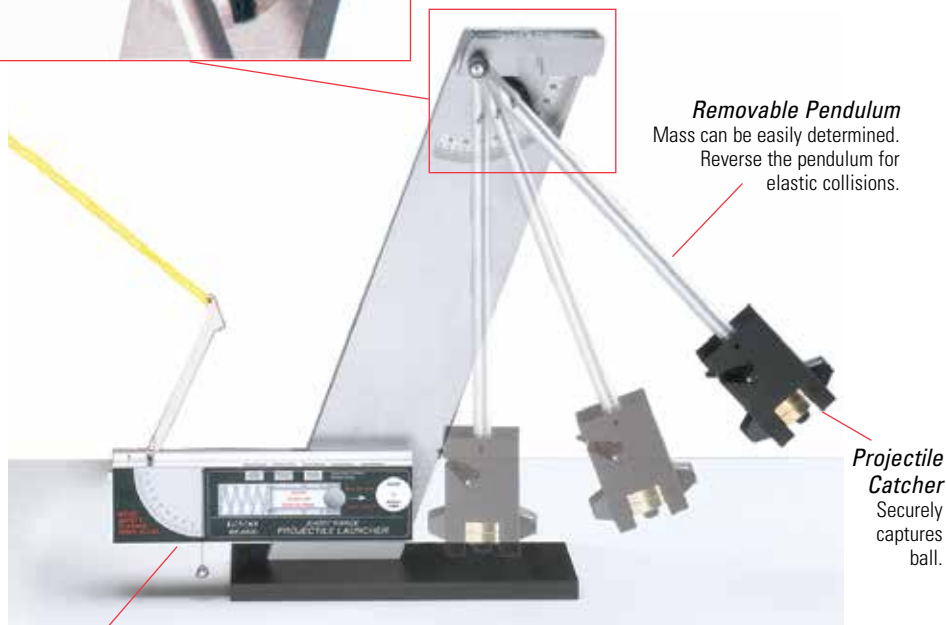

## Removable Pendulum

Mass can be easily determined.  
Reverse the pendulum for elastic collisions.

Projectile Catcher  
Securely captures ball.

## Projectile Launcher

Durable with three repeatable launch settings.



## Add Masses

Two 50 g masses (included) can be added to change the pendulum mass and rotational inertia.

PASCO's Ballistic Pendulum—  
A New Approach

The PASCO Ballistic Pendulum has the following unique features:

**Repeatable:** The three velocity settings on the Projectile Launcher produce consistent velocities.

**Accuracy:** The  $0\text{--}80^\circ$  angle measurement scale resolves to  $1/2^\circ$ , leading to experimental results within 2.5% of predicted values.

**Removable Pendulum:** Remove the pendulum to determine its mass and center of mass. It can swing freely so students can determine its rotational inertia. Mount the pendulum backwards so the ball bounces away for elastic collision experiments.

## Vary Ball and Pendulum Mass:

Two 50 g masses can be added to the pendulum, and two steel and two plastic balls are included.

**Projectile Launcher:** Mount the Projectile Launcher on the other side of the base, and students have access to all the accessories that come with the Projectile Launcher ME-6800 (see page 124).

## Includes

- Ballistic Pendulum and Base
- Projectile Launcher
- Projectile Launcher Base
- 2.5 cm Plastic Balls (2)
- 2.5 cm Steel Balls (2)
- Masses (2)
- 2-D Collision Accessory
- Safety Glasses (2 pairs)
- Operations and Experiment Manual



## Order Information

Ballistic Pendulum .....ME-6830

Ballistic Pendulum  
(No Launcher).....ME-6831

## Recommended:

Spherical Mass Set.....ME-8968 p. 129

Shoot-the-Target.....ME-6853 p. 127

Time-of-Flight.....ME-6810A p. 129

Large C Clamp  
(6 pack) .....SE-7285 p. 129

## Ballistic Pendulum Accessory

ME-9892 (for use with the ME-6800 Projectile Launcher on page 124)

- ▶ Both are accessories to the Rotary Motion Sensor
- ▶ For elastic and inelastic experiments
- ▶ Low cost

Both of these ballistic pendulum accessories use a Rotary Motion Sensor to measure the speed of the catcher assembly immediately after the collision, as well as the maximum height to which the pendulum swings. The Rotary Motion Sensor can also be used to measure the rotational inertia of the pendulum, for detailed study of the collision using conservation of angular momentum.

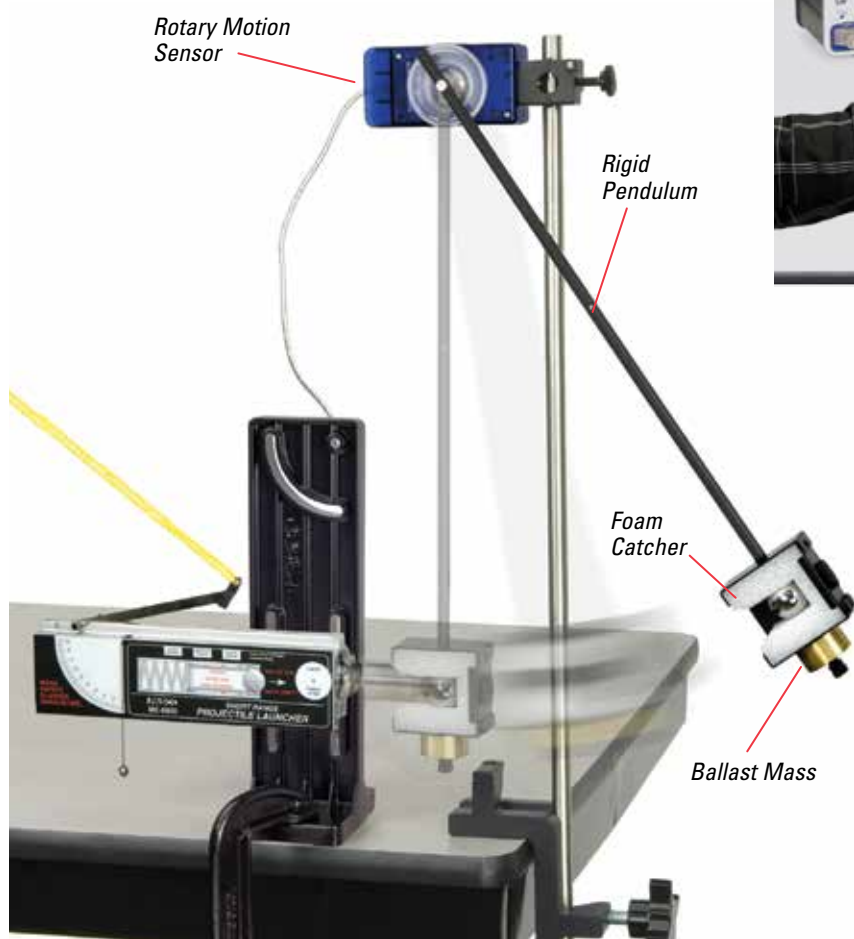

## Mini Launcher Ballistic Pendulum Accessory

ME-6829 (for use with the ME-6825B Mini Launcher on page 125)

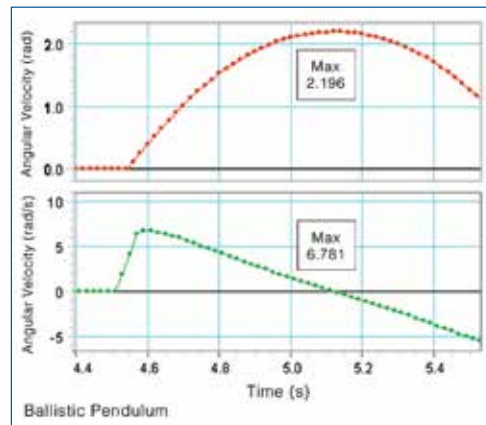

Rotary Motion Sensor (required for use) allows measurement of instantaneous velocity of catcher immediately after collision, as well as total angle of rotation of the pendulum arm.

### Both accessories include:

- Pendulum Arm with Catcher
- Ballast Mass
- Steel Ball



### Order Information

Mini Launcher Ballistic Pendulum Accessory ..... ME-6829

Required:

Mini Launcher ..... ME-6825B p. 125

Rotary Motion Sensor ..... PS-2120A or CI-6538 p. 25

### Order Information

Ballistic Pendulum Accessory..... ME-9892

Required:

Projectile Launcher ..... ME-6800 p. 124

Rotary Motion Sensor ..... PS-2120A or CI-6538 p. 25

# Statics

## Dynamics Track Support Reactions

Combine the plastic PAStack sections (page 100) with the components from the Advanced Structures Set (page 143) to measure the support reactions as the Motorized Cart climbs the hill. The Load Cell and Amplifier Set (page 140) directly measures the forces in the structure as the Motion Sensor measures the cart's position.

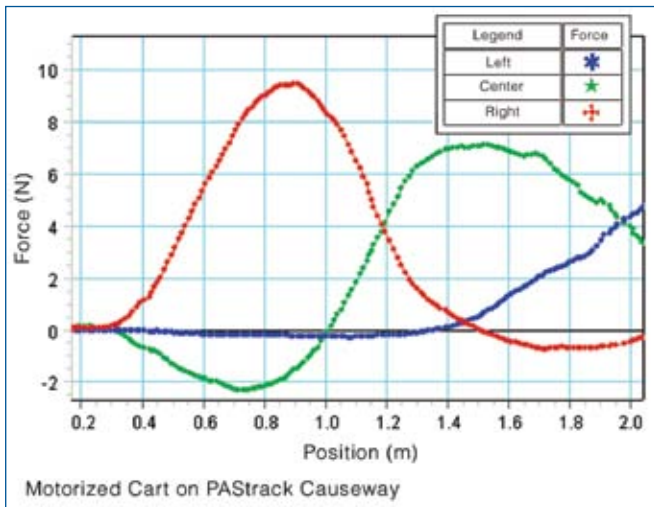
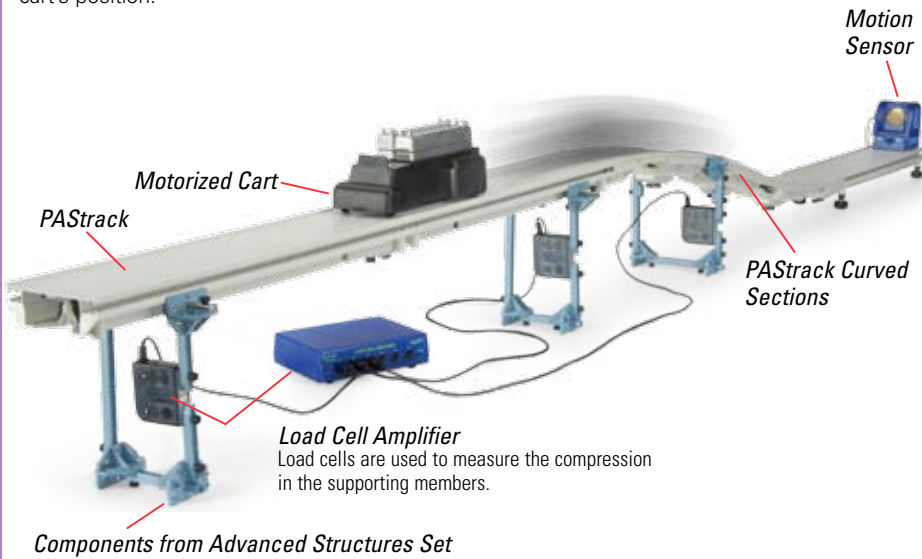

Force vs. Position of the cart for each of the support forces as the Motorized Cart climbs the hill

### Order Information

PAStack.....	ME-6960	p. 100
Motorized Cart.....	ME-9781	p. 102
250 g Mass.....	ME-6757A	p. 111
Advanced Structures Set.....	ME-6992B	p. 143
Load Cell & Amplifier.....	PS-2199	p. 140
Motion Sensor.....	PS-2103A	p. 24

## Equal Arm Balance

ME-8949

Developed for  
Workshop Physics®  
activities



The Equal Arm Balance was specially designed to simplify the study of torques. This balance has a ball-bearing pivot.

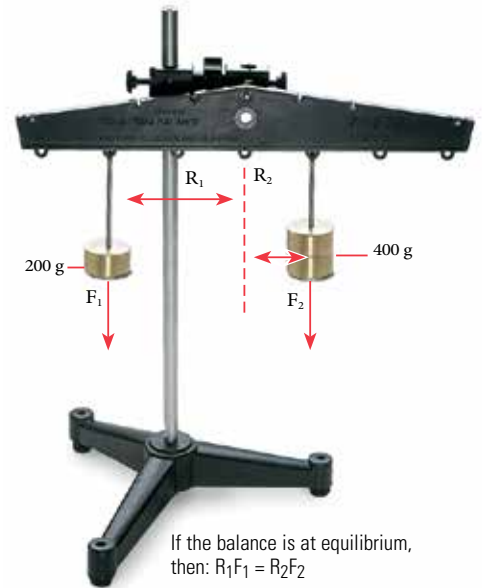

With 200 g and 400 g masses placed as shown above, the balance remains in equilibrium.

### Specifications

- Total length:** 34 cm
- Maximum weight exerted on balance arm:** 1 kg or 10 N



### Includes

- Balance Arm with Ball-Bearing Pivot

### Order Information

Equal Arm Balance.....	ME-8949	
Required:		
Drilled Mass and Hanger Set.....	ME-8979	p. 187

## Force Table

ME-9447B

- ▶ High accuracy
- ▶ Easy, compact storage
- ▶ Inexpensive!

### Adjustable height

The swivel feature of the pulleys can virtually eliminate parallax for more precise angle measurements.

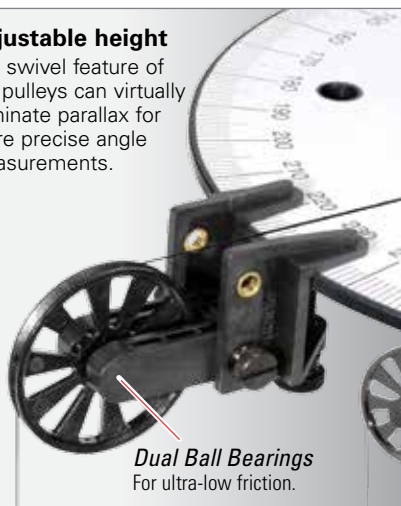

**Dual Ball Bearings**  
For ultra-low friction.

**Built-in Scale**  
Measure angles quickly and accurately.

### String tie

String Tie is captured to make set-up of hanging masses easy, but it freely floats over bulls-eye pattern to clearly show even small changes in equilibrium.



Strings connect to center of String Tie for accurate results.

**Compact, Easy Storage**



### Improved leg storage

The screw-in legs snap under the table for easy storage.

### Improved stacking

Stacked tables are keyed together to eliminate slipping. Now you can store all your Force Tables in one convenient stack!



Stacking tab keys into recess in table-top.

**Mass and Hanger**  
(sold separately)

Change the mass by 1/2 gram or an angle by 1/2 degree and see an immediate change in the equilibrium.

### Includes

- 25 cm diameter table with detachable legs
- Adjustable Super Pulleys with Clamps (3)
- Spool of thread (1)



Mass and Hanger Set is sold separately.

### Order Information

Force Table.....	ME-9447B	
<b>Required:</b>		
Mass and Hanger Set .....	ME-8979	p. 187
<b>Additional Pulleys:</b>		
Super Pulley with Clamp .....	ME-9448B	p. 180

# Statics

## Tension Protractor

ME-6855

- ▶ Measure tension and angle with one device
- ▶ Large scale for viewing demonstrations
- ▶ Zero-adjust for torsion spring scale
- ▶ Built-in rod clamp

The Tension Protractor is a spring scale and a protractor integrated into one device. Perfect for static equilibrium experiments, the rotary dial indicates the tension in the string and the angle is read where the string passes over the degree scale on the outer ring. Since the Tension Protractor is supported on a rod, it has an advantage over other spring scales which tend to weight down the string, changing the angle.

The string is wrapped once around a small pulley which is spring loaded. The torsion spring scale is carefully calibrated at the factory and can be zeroed by the user using the thumb screw on the back. The red arrow which indicates tension is color-coded to match the Newton scale.

Even if the mounting rod is not plumb, the Tension Protractor's degree scale can be adjusted to read 90 degrees vertically by rotating the outer ring until the string with a hanging mass aligns with 90 degrees.

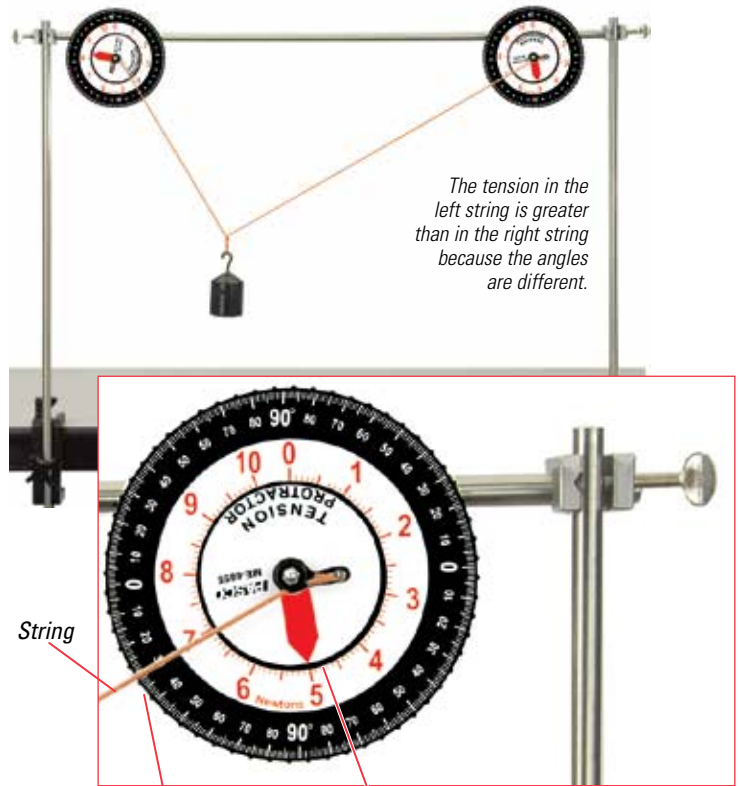

The tension in the left string is greater than in the right string because the angles are different.

Zeroing Ring for Angle Scale

Rod Clamp mounts on either a vertical or horizontal rod.

30° angle reading

Arrow indicates tension reading (5.0 N)

Zeroing Thumb Screw for Force Scale

### Specifications

- Force Range:** 0 N to 10 N
- Smallest Force Division:** 0.1 N
- Force Accuracy:** ±4% of Reading
- Angle Range:** -90° to +90°
- Smallest Angle Division:** 1°
- Diameter:** 15 cm

### Includes

- One Tension Protractor

### Order Information

Tension Protractor .....	ME-6855	
<i>Recommended:</i>		
Large Table Clamp .....	ME-9472	p. 179
90 cm Long Rod .....	ME-8738	p. 176
Multi-clamp .....	ME-9507	p. 178
Hooked Mass Set .....	SE-8759	p. 187



A 50 gram mass hangs vertically from the Tension Protractor. The tension reads 0.5 N as expected and the outer degree scale is dialed to align the 90° mark with the string. This compensates for unlevel tables or bent rods.

## Statics System

ME-9502

- ▶ Everything required for 15 experiments
- ▶ Comprehensive — from vector addition to simple machines
- ▶ Easy Setup — magnetic mounting

A versatile lab system for demonstrating the basic concepts of vector forces, torques, center of mass, simple machines, and more. The ME-9503 Statics Board (sold separately) doubles the width and is perfect for demonstrations.

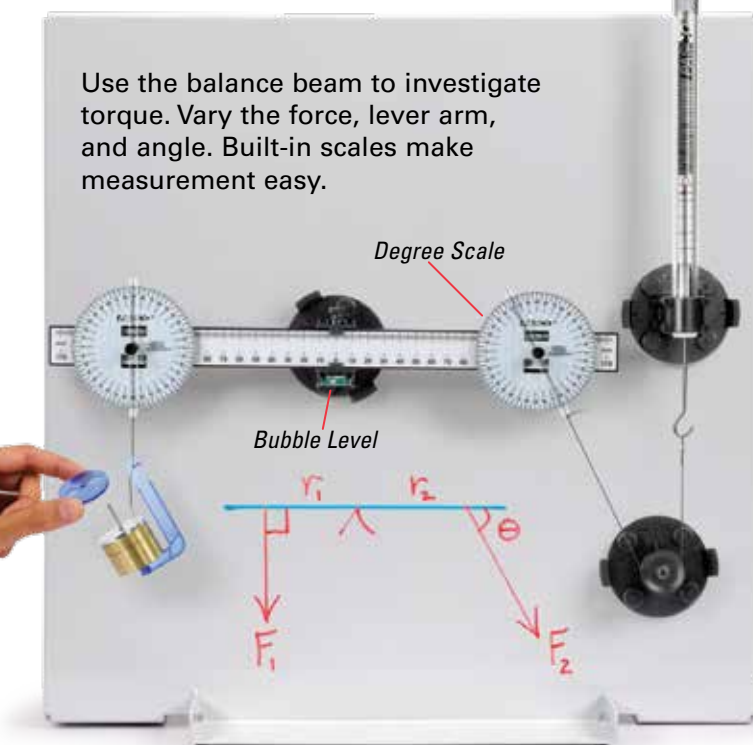
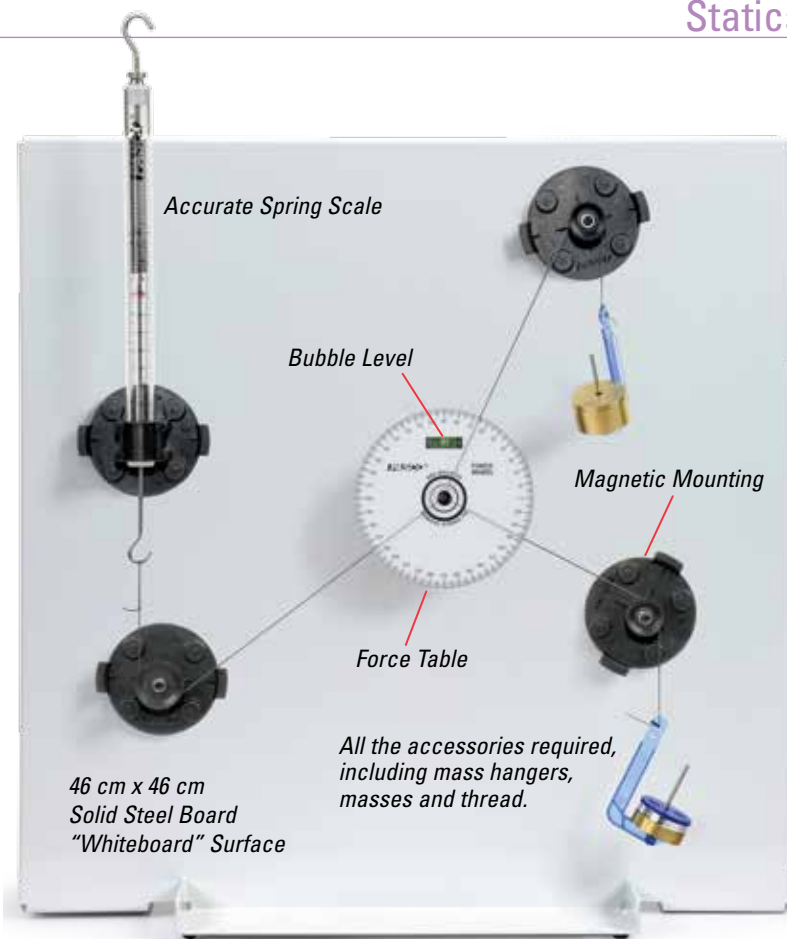

### Easy Storage

Store magnetic components on back of experiment board.

### Includes

- Experiment Board
- Components
- Mass Set
- Comprehensive Manual



### Order Information

Statics System.....	ME-9502
<i>Additional Equipment:</i>	
Statics Board.....	ME-9503
Spring Scale.....	ME-9824A
Statics Spares Package.....	ME-9504

## Forces and Machines

## Forces and Machines

## Curriculum

## Forces and Machines Teacher Resources

EP-6483

- ▶ A single teacher guide is all you need to outfit your class or lab.
- ▶ Complete with guided inquiry lab activities, suggested answers, and much more.
- ▶ Requires Forces and Machines Engineering kit

Questions are embedded throughout the activities, sequencing and key term challenges, opportunities to predict outcomes prior to data collection and post-lab multiple choice questions all help to make the connection between lectures and labs as seamless as possible. And they are all correlated to state and national standards. For more information, visit [pasco.com](http://pasco.com)

## Equipment

## Forces and Machines Engineering Kit

EP-3577

Our Forces and Machines Kit engages students in a wide range of physics, physical science, and engineering concepts. Two triple-pulley blocks make it easy to build machines with mechanical advantage up to 6:1. Build all three classes of levers with our pair of 20-cm levers, or combine gears, levers, and pulleys together to show how rotating machines work.

## Includes

- Extruded rail
- 10 N metal spring scales (2)
- Tripod stands (2) & crossrail
- Universal spring hanger
- Right-angle connector with pulley (2)
- Fixed triple pulley block
- Hanging triple pulley block
- 25 cm Hooke's law spring
- Friction block
- Quick-attach gear hubs (4)
- Gear spacers (8)
- 20 cm levers (2)
- 60 tooth spur gears (2)
- 40 tooth spur gears (2)
- 20 tooth spur gears (3)
- 20 cm dia. large pulleys (2)
- Weights



## Order Information

Forces and Machines Teacher Resources .....EP-6483  
 Forces and Machines Engineering Kit .....EP-3577

## Tripod Stand

EP-3572

## Includes

- 68.6 cm extruded aluminum vertical rail
- Wide tripod base with aluminum legs and rubber feet
- Includes 5 sliding 14-20 inserts, already installed

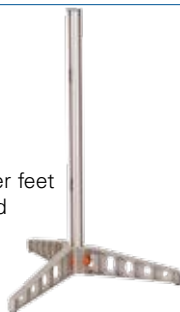

## Order Information

Tripod Stand .....EP-3572

## Weights

EP-3563

## Includes

- 2 mass hangers
- 25 fender washer masses



## Order Information

Weights.....EP-3563



## Super Pulley

ME-9450A

- ▶ 20 N max load
- ▶ Nearly frictionless
- ▶ Durable

The PASCO Super Pulley is the standard in physics labs. Its low-friction design produces excellent results. The precision spacing of the 10 spokes makes it ideal for photogate monitoring with PASCO's computer interfaces and photogate systems.



### Features

- ▶ Low Friction
- ▶ Lightweight
- ▶ Precision Dimensions

### Order Information

Super Pulley ..... ME-9450A

## Pulley Mounting Rod

SA-9242

This 14 cm long stainless steel mounting rod is 9.5 mm (3/8 in.) in diameter and fits most standard laboratory clamps, including the PASCO Universal Clamp.



### Order Information

Pulley Mounting Rod  
(rod only) ..... SA-9242

## Smart Gate Pulley System

PS-3702

The Super Pulley attaches directly to the Smart Gate, providing a simple, low-friction system to measure position, velocity and acceleration. Additionally, with the pulley removed, the photogate can be used to perform standard photogate experiments.



### Includes

- Smart Gate (1) PS-2180
- Super Pulley (1) ME-9450A
- Super Pulley Rod (1) ME-8736

### Order Information

Smart Gate Pulley System.....PS-3702

## Super Pulley with Mounting Rod

ME-9499

This Super Pulley mounted on a rigid plastic mounting rod (12.7 mm diameter, 14 cm long) fits most standard laboratory clamps.



### Order Information

Pulley with  
Mounting Rod ..... ME-9499

## Super Pulley with Clamp

ME-9448B



Upgrade your force table and inclined plane experiments. The Super Pulley with its integral clamp makes setup and alignment easy. The pulley height is fully adjustable, so you can skim the top of a force table for parallax-free readings. Yet you can keep the force parallel to the track on an inclined plane, as shown in the photo below. Fits tables up to 2.0 cm (13/16 in.) thick.



### Order Information

Super Pulley  
with Clamp .....ME-9448B

## Mounting Rods (10 pack)

ME-9483

These rigid plastic pulley handles (14 cm long, 1.27 mm diameter) screw into a Super Pulley.



### Order Information

Mounting Rods  
(10 pack) .....ME-9483

## Photogate/Pulley System

ME-6838A

The Super Pulley attaches directly to the Photogate Head, providing a simple, low-friction system to measure position, velocity and acceleration. Additionally, with the pulley removed, the photogate can be used to perform standard photogate experiments. See page 39.

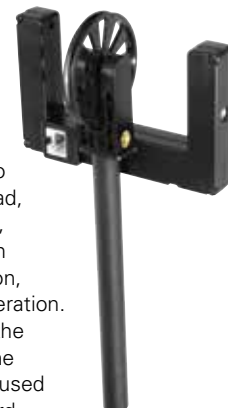

### Order Information

Photogate/Pulley  
System ..... ME-6838A

## Atwood's Machine

SA-9241



Two Super Pulleys mounted on a 6.4 cm long rod produce a classic, low-friction introduction to Newton's Second Law. The instruction sheet fully describes both the experiment and the theory.



### Includes

- Pulleys (2)
- Connecting Rod (1)

### Order Information

Atwood's  
Machine.....SA-9241

# Human Applications

## Human Arm Model

PS-2611

- ▶ Working model of the human arm
- ▶ Associate tricep/bicep muscle action with arm motion
- ▶ Measure torque resulting from lifting weights
- ▶ Actually throws a ball

The Human Arm Model simulates the muscles and motion of an actual human arm. To activate the arm motion, students pull on the cord with a Force Sensor. Changes in position are measured at the shoulder and elbow using the two built-in potentiometers plugged into one Angle Sensor (PS-2139), included with PS-2611. From this information, the torque applied when lifting an object can be determined. Also, students can evaluate the work done by the arm in throwing a ball and the resulting kinetic energy delivered to the ball.

The Arm can perform many types of motion such as extending and lifting an object, curling, or throwing a ball overhand. Different arm muscles are activated depending on which pulleys are selected. Static force measurements can also be made to see how the muscle tension changes at various arm positions.

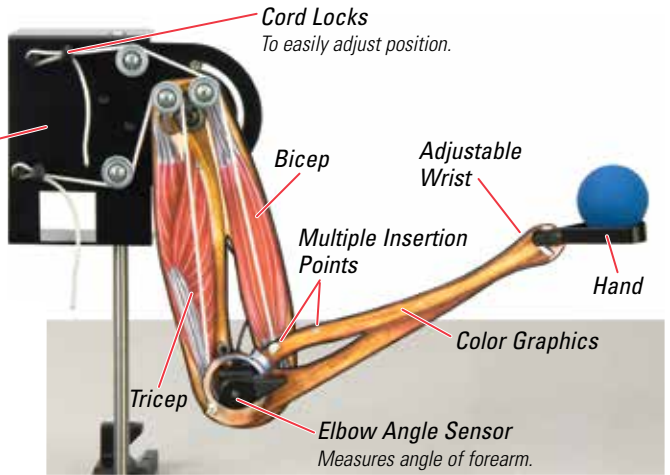

**Mounting Bracket**  
Use with rod or clamp directly to a table with a C-clamp.

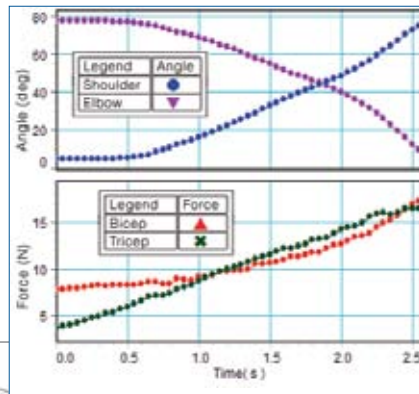

### Angles and Forces During Extension:

The upper graph shows the angles of the elbow (violet trace) and the shoulder (blue) as the arm is extended as shown in the picture at right. Shown in the lower graph, the bicep tension (red) has little change at first and then rises sharply as the arm reaches out, while the tricep tension (green) rises steadily.

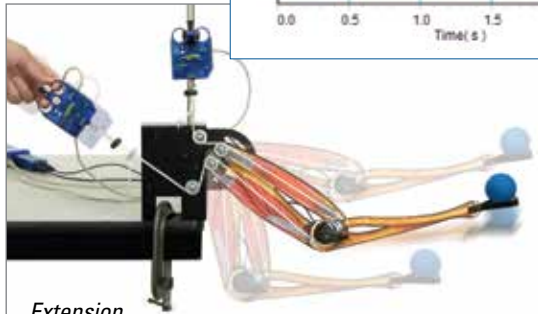

### Extension

As the tricep muscle cord is pulled with a Force Sensor, another fixed Force Sensor records the tension in the bicep muscle cord.

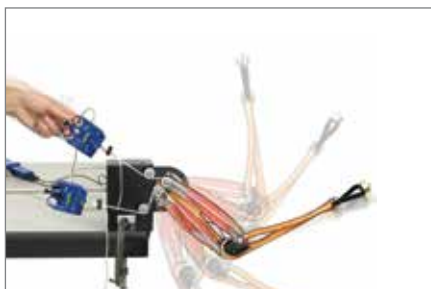

### Curl

As the bicep muscle cord is pulled a short distance, the end of the arm moves through a very large distance, showing the mechanical advantage of the arm. The load at the end of the arm can be varied.



### PS-2611 includes

- Arm
- Angle Sensor
- Removable Mass
- Cord & Cord Locks
- Mounting Bracket with Rod
- Force Sensor Mounting Rod
- Rubber Ball

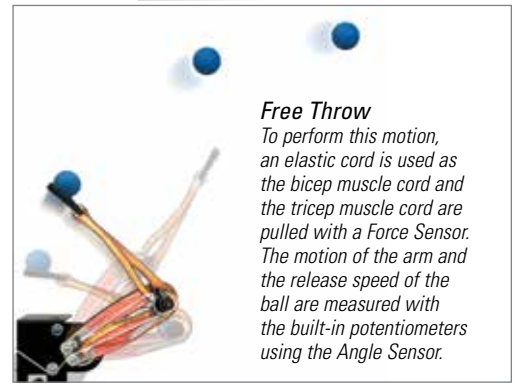

### Free Throw

To perform this motion, an elastic cord is used as the bicep muscle cord and the tricep muscle cord are pulled with a Force Sensor. The motion of the arm and the release speed of the ball are measured with the built-in potentiometers using the Angle Sensor.

### Order Information

Human Arm Model ..... PS-2611

Required:

"C" Clamp or Large Table Clamp ..... p. 179  
 Force Sensor (2)..... PS-2104 ..... p. 28  
 850 Universal Interface..... UI-5000 ..... p. 12

## Goniometer

PS-2137

- ▶ Accurately measures joint movements
- ▶ Flexible mounting options for hip, knee, and elbow

The SPARKlink® Air Interface is used here with two Angle Sensors, part of the PS-2137 Goniometer System. The data is sent via Bluetooth to a desktop computer, and displayed live with the video being recorded by a web cam.

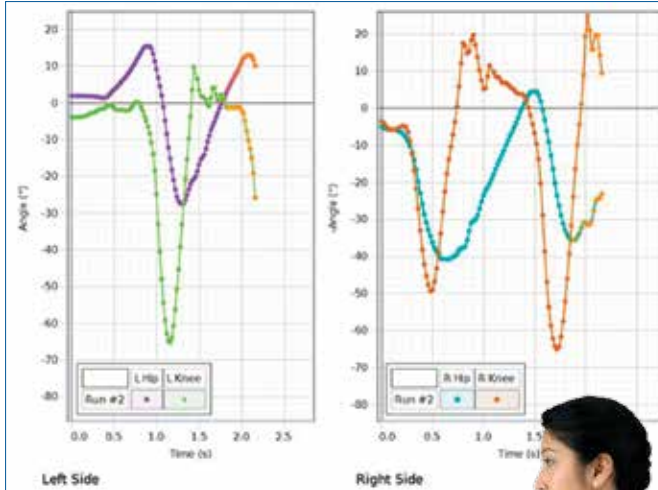

Data shows position of both left and right knee and hip joints during walking.

### Capture data remotely!

The SPARKlink Air Interface records the sensor data, and sends it to the computer via Bluetooth.



### Goniometer Probes

The probes are fastened in place using the blue Velcro® straps, and can be positioned to measure the motion of the knee, hip, or elbow.



### Specifications

**Range:** 0 to 340°

**Accuracy:** ±1° (calibrated), ±3° (uncalibrated)

**Resolution:** 0.1°

### Includes

- Goniometer Probe
- Angle Sensor
- Velcro Straps



### Order Information

Goniometer Sensor.....	PS-2137	
<i>Recommended:</i>		
SPARKlink Air .....	PS-2011	p. 10
Additional Velcro Straps.....	PS-2547	
Additional Goniometer Probe.....	PS-2138	p. 67

## Forces on the Human Body

- ▶ Measure forces on human body
- ▶ 1-axis and 2-axis force platforms
- ▶ Precise and fast

Explore the forces exerted on the human body in everyday situations, sports, and large-scale physics experiments. The Force Platforms are designed to measure large forces, such as the weight of a person.

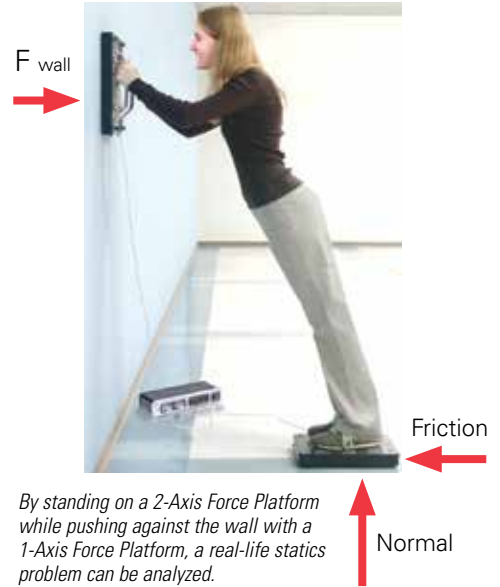

By standing on a 2-Axis Force Platform while pushing against the wall with a 1-Axis Force Platform, a real-life statics problem can be analyzed.



Confirm Newton's Third Law by pushing on a Force Platform using two sets of handles (available separately). Handles bolt onto the Force Platform (1 axis or 2-axis). Can be mounted on either side or both sides.

Developed in cooperation with Nancy Beverly, Assistant Professor of Physics at Mercy College, Dobbs Ferry, New York.

### Order Information

2-Axis Force Platform .....	PS-2142	p. 31
Force Platform .....	PS-2141	p. 31
<i>Recommended:</i>		
Handle Set.....	PS-2548	p. 31

# Structures Systems

*Build any structure and instrument it.*

## Load Cell & Amplifier Set

PS-2199

- ▶ Measure the compression and tension in the I-beam members
- ▶ Insert load cells into structures by substituting beams
- ▶ Amplifier accepts up to 6 load cells
- ▶ Use more than 6 load cells by connecting multiple amplifiers to one computer

A load cell can be inserted into the design by replacing one beam with a load cell connected to two shorter beams. There is no need to completely disassemble the structure to add instrumentation.

PS-2199 includes four 100 N Load Cells and additional load cells can be purchased separately. For more information, see page 33.

Shown in use with Bridge Set ME-6991. Sold on page 142.

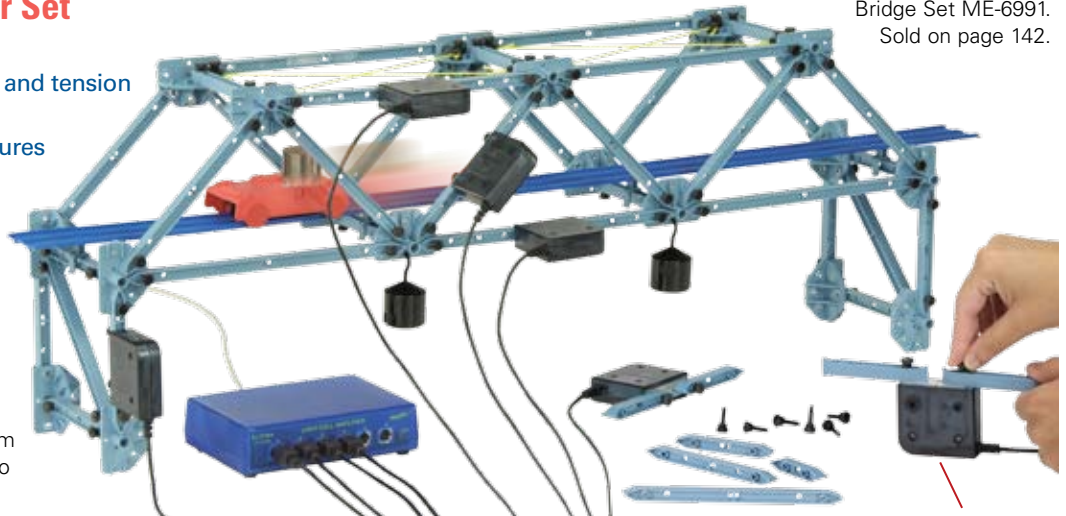

I-beams key into the load cell and are fastened with thumb screws.

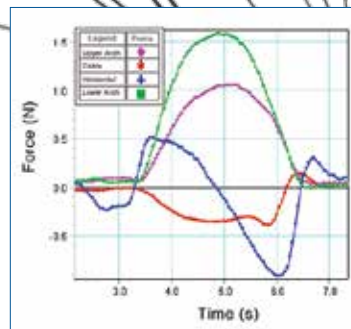

As the car crosses the bridge, the forces measured by each load cell are graphed in real-time in PASCO Capstone™. Notice the diagonal member (green trace) switches from compression to tension as the car passes by.

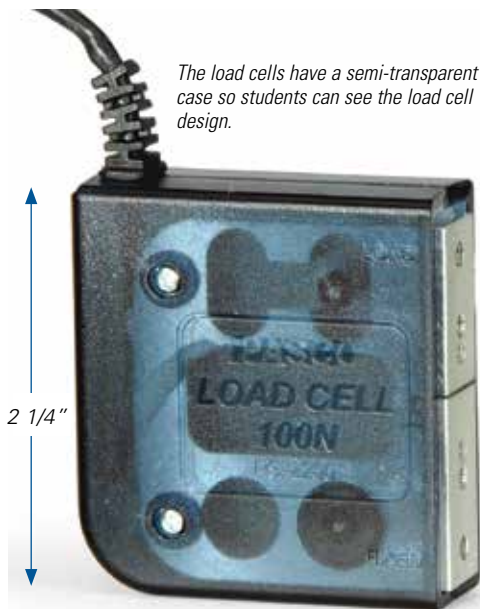

The load cells have a semi-transparent case so students can see the load cell design.

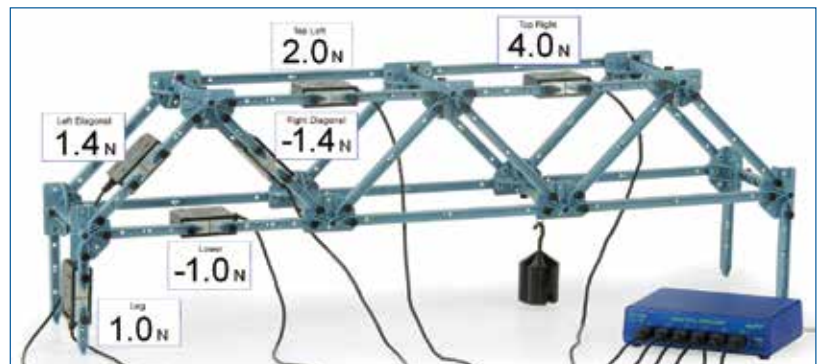

Forces measured by Load Cells are displayed on a computer using PASCO Capstone software. A positive value represents compression.

Also see Dual Load Cell Amplifier on page 32 in the sensor section.

### Includes

- Load Cell Amplifier
- 100 N Load Cell (4)



### Order Information

Load Cell & Amplifier Set (includes 4 load cells) .....	PS-2199	p. 32
<i>Required:</i>		
PASPORT Interface to USB Computer .....		p. 10-11
<i>Recommended:</i>		
Additional 100 N Load Cell .....	PS-2200	p. 33
Load Cell 5N.....	PS-2201	p. 33
Hooked Mass Set.....	SE-8759	p. 187

## Truss Set

ME-6990

- ▶ Teach the basics of trusses
- ▶ Demonstrate the properties of I-Beams

Through Truss  
with Verticals

*Plastic I-Beams*

*Plastic Connectors*

*Steel Thumb Screws*

Use the Truss Set to build a variety of structures to investigate the principles of trusses. The ABS plastic I-Beams fasten securely together using the provided connectors and thumb screws. Load cells can be inserted anywhere into the design by replacing one beam at a time. Students can load the truss by hanging weights.

*Measure the compression and tension in the I-Beam members by adding optional Load Cells.*

**Construction is easy:** I-Beams fit into the connectors and are secured with thumb screws. Thumb screws are also slotted so a screwdriver can be used.

I-Beams key into the load cell and are fastened with thumb screws.



Deck Truss Bridge

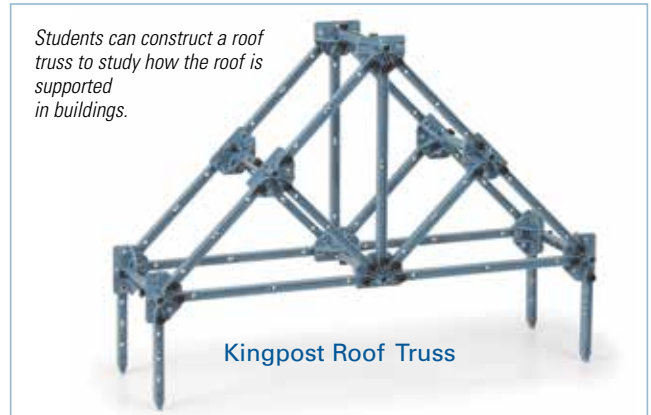

*Students can construct a roof truss to study how the roof is supported in buildings.*

Kingpost Roof Truss

### Truss Set Includes

- I-Beam #5 (8) 24 cm long
- I-Beam #4 (18) 17 cm long
- I-Beam #3 (18) 11.5 cm long
- I-Beam #2 (8) 8 cm long
- I-Beam #1 (8) 5.5 cm long
- Connectors (14), Screws (75), and Instruction manual



### Order Information

Truss Set\* ..... ME-6990

*Recommended:*

Load Cell & Amplifier Set\*  
(includes four load cells)..... PS-2199

p. 32

# Structures System

## Bridge Set

ME-6991

- ▶ Larger quantity of I-beams and connectors
- ▶ Study the principles of bridge construction
- ▶ Road bed and car add realism to bridges
- ▶ Add Load Cells to see dynamic loading as car traverses bridge

Warren with Verticals  
1.5 m long

Cross bracing

Verticals to support road bed

Car with Mass

Flexible Road Bed

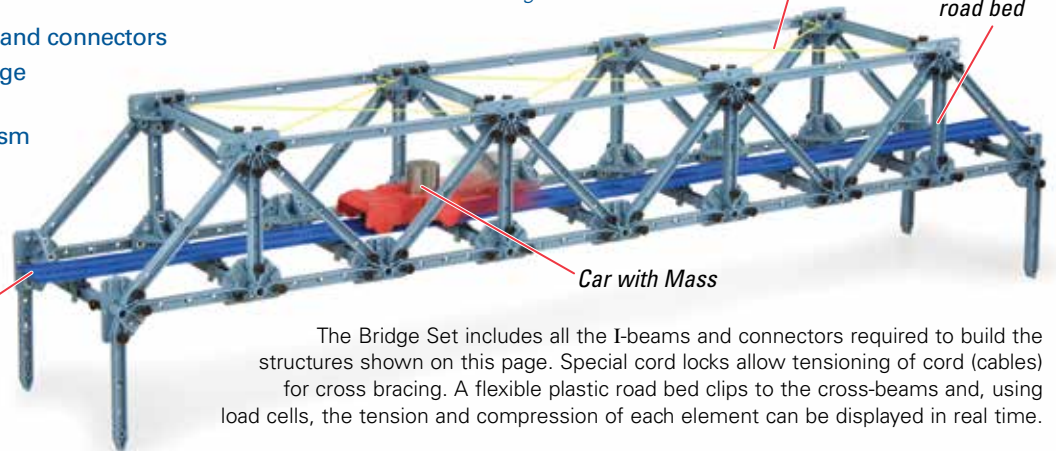

The Bridge Set includes all the I-beams and connectors required to build the structures shown on this page. Special cord locks allow tensioning of cord (cables) for cross bracing. A flexible plastic road bed clips to the cross-beams and, using load cells, the tension and compression of each element can be displayed in real time.

Add Load Cells to measure forces anywhere in the structure. A positive value represents compression.

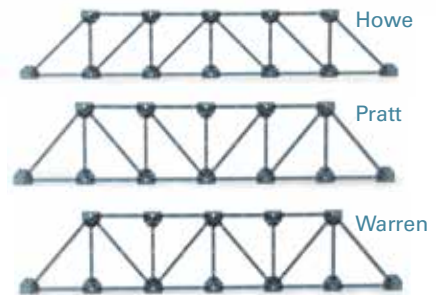
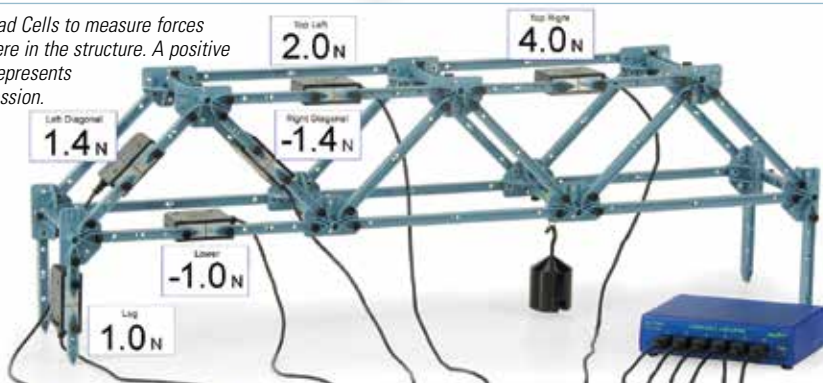

Students can build several types of fundamental bridges, including Howe, Pratt, and Warren bridges.

### Design your own roller coaster!

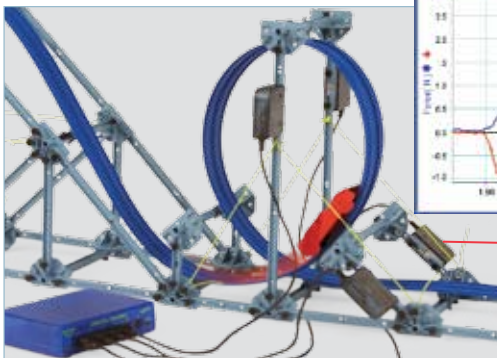

Add Load Cells to measure the forces needed to support the track as the car goes up and over the loop. See p. 141 for more roller coasters.

Deck Truss  
80 cm long



Waddell "A" Truss  
1 m long

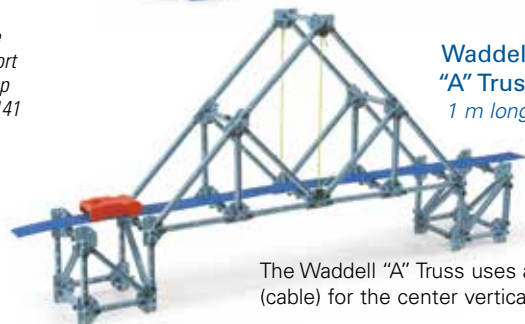

The Waddell "A" Truss uses a cord (cable) for the center vertical member.

### Bridge Set Includes

- I-beam #5 (16) 24 cm long
- I-beam #4 (36) 17 cm long
- I-beam #3 (36) 11.5 cm long
- I-beam #2 (16) 8 cm long
- I-beam #1 (16) 5.5 cm long
- Connectors (28)
- Screws (150)
- Flexible road bed (3 m)
- Track coupler
- Road bed clips (24)
- Car with flag and mass
- Starter bracket
- Cord tensioning clips (32)
- Yellow cord (1 roll)
- Instruction manual



### Order Information

Bridge Set .....ME-6991  
**Recommended:**  
 Load Cell & Amplifier Set  
 (includes four load cells).....PS-2199

## Advanced Structures Set

ME-6992B

- ▶ Build larger bridges
- ▶ Build cranes, catapults, cars

The Advanced Structures Set includes more components to build a larger variety of structures. Axles and pulleys allow construction of cranes, cars and even a working catapult!

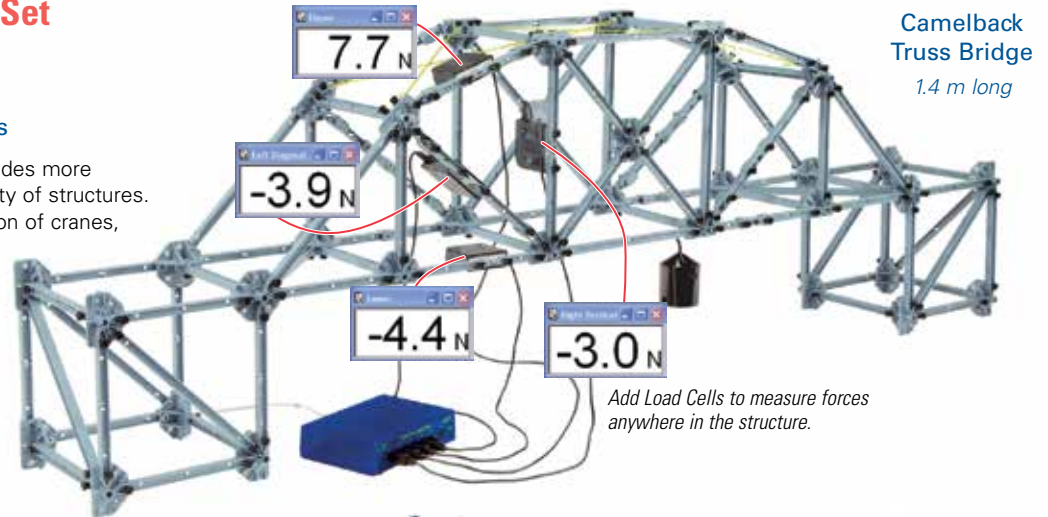

Camelback Truss Bridge  
1.4 m long

Add Load Cells to measure forces anywhere in the structure.

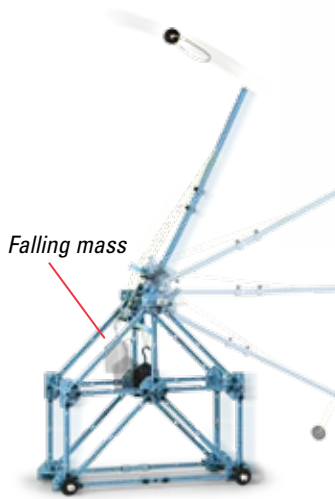

Falling mass

Catapult  
60 cm tall  
Throws a projectile over 10 meters!  
Wheels allow catapult to move.



Angle Crane  
1.5 m tall

Use pulleys to investigate mechanical advantage.

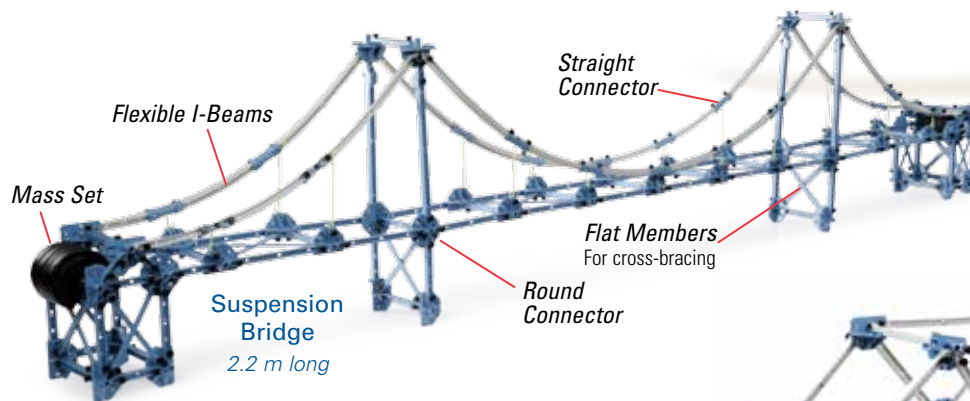

Suspension Bridge  
2.2 m long

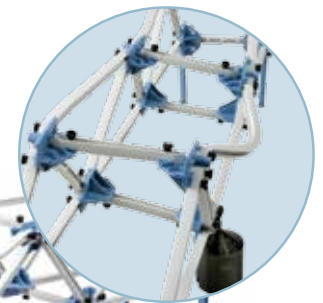

Flexible I-Beams  
Dramatically demonstrate structural failure

### Advanced Structures Set Includes:

- Force Platform Bracket (2)
- I-Beam #5 (24) 24 cm long
- I-Beam #4 (54) 17 cm long
- I-Beam #3 (54) 11.5 cm long
- I-Beam #2 (24) 8 cm long
- I-Beam #1 (24) 5.5 cm long
- Flex I-Beam #5 (10) 24 cm long
- Flex I-Beam #4 (18) 17 cm long
- Flex I-Beam #3 (18) 11.5 cm long
- Flat Beams (16 ea. of 3 lengths)
- Axles (2 ea. of 3 lengths)
- Connectors (42)
- Cord Tensioning Clips (32)
- Round and Flat Connectors (6 ea.)
- PAStack Fasteners (6)
- Angle and Straight Connectors (24 ea.)
- Sliding Connector (12)
- Pulleys, O-rings, Spacers (12 ea.)
- Collets (24)
- Drive Wheel with Rubber Tire (4)
- Structures Rod Clamps (2)
- Screws (300)
- Yellow Cord (1 roll)
- Instruction Manual



### Order Information

Advanced Structures Set.....ME-6992B  
Shown in use with:  
Load Cell & Amplifier Set  
(includes four Load Cells).....PS-2199  
Hooked Mass Set.....SE-8759  
Large Slotted Mass Set.....ME-7566

## Structures Systems

## Large Structures Set

ME-7003

The Large Structures Set includes all the components contained in the ME-6992B Advanced Structures Set plus additional parts to build even bigger structures. It also includes the Mini Cars with plastic track to build roller coasters, and to add realistic roadbeds to your bridges.

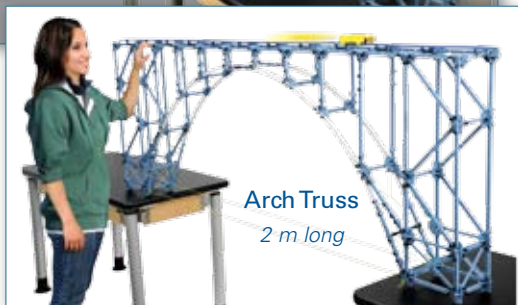
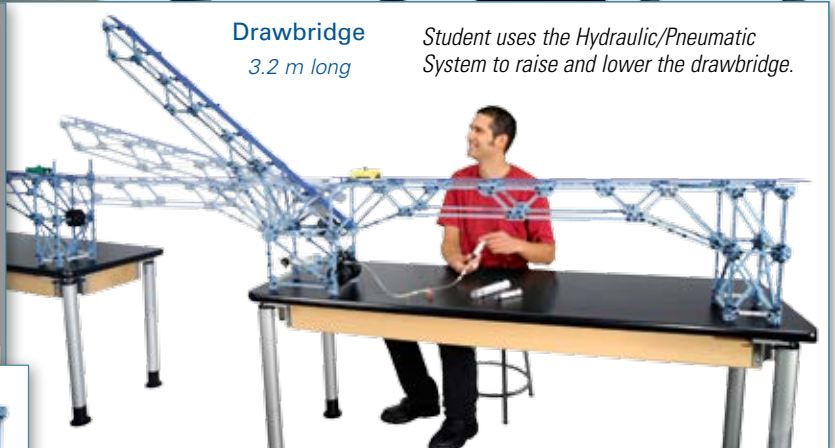
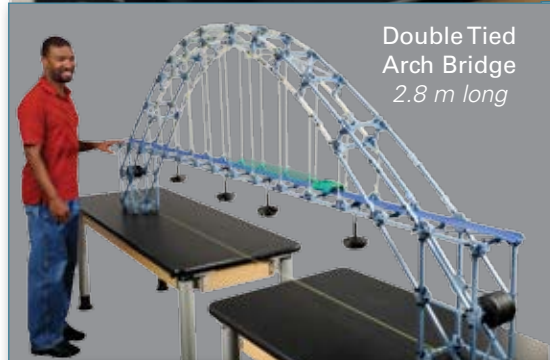
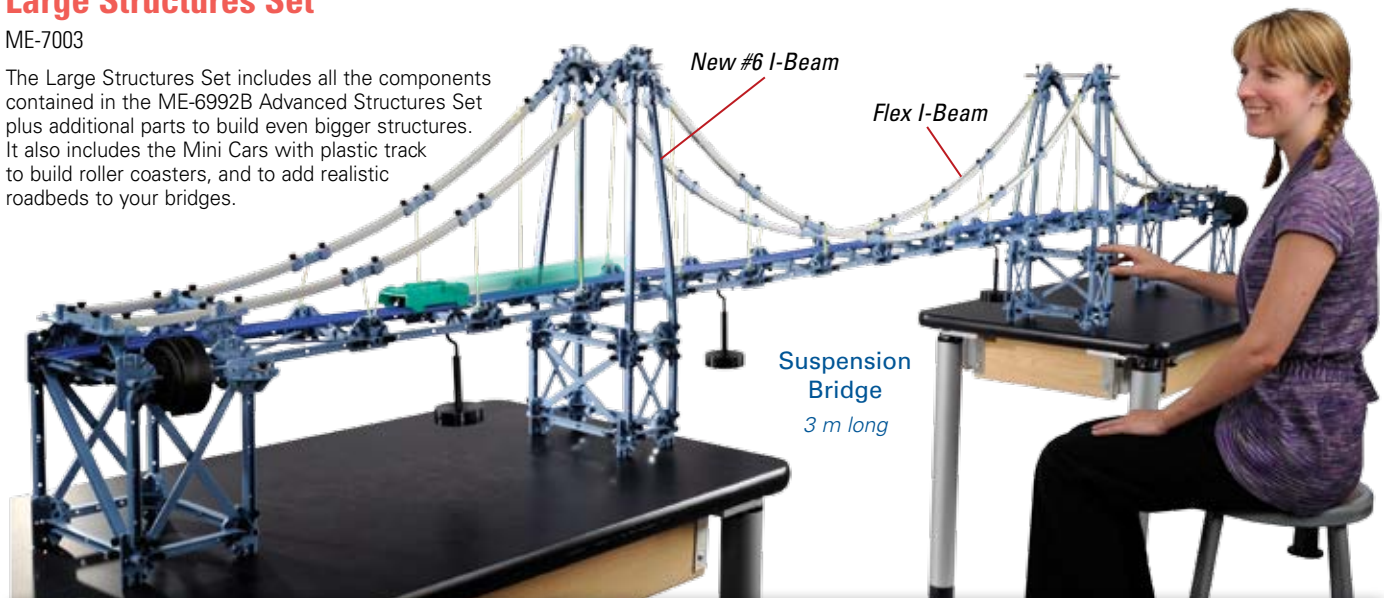

Add load cells to measure forces anywhere in the structure.



## Large Structures Set Includes

- I-Beam #6 (24) 35 cm long
- I-Beam #5 (24) 24 cm long
- I-Beam #4 (54) 17 cm long
- I-Beam #3 (54) 11.5 cm long
- I-Beam #2 (24) 8 cm long
- I-Beam #1 (24) 5.5 cm long
- Flex I-Beam #5 (10) 24 cm long
- Flex I-Beam #4 (18) 17 cm long
- Flex I-Beam #3 (18) 11.5 cm long
- Flat Beams (16 ea. of 3 lengths)
- Axles (2 ea. of 3 lengths)
- Connectors (70)
- Cord Tensioning Clips (32)
- Yellow car and green car, each with ballast mass and flag
- Force Platform Bracket (2)
- Round and Flat connectors (6 ea.)
- Angle and Straight Connectors (24 ea.)
- Drive Wheel with Rubber Tire (4)
- Pulleys, O-rings, Spacers (12 ea.)
- Structures Rod Clamps (2)
- Sliding Connector (12)
- PASTrack Fasteners (6)
- Collets (24)
- Screws (450)
- Yellow Cord (1 roll)
- Flexible road bed (9.1m)
- Road bed clips (24)
- Starter bracket (1)
- Track coupler (2)
- Instruction Manual



## Order Information

Large Structures Set.....ME-7003  
 Shown in use with:  
 Hydraulic/Pneumatic Structures.....ME-6984  
 Load Cell & Amplifier Set (includes four Load Cells)....PS-2199 p. 32  
 Slotted Mass Set.....ME-7589 p. 187

## Human Structures Set

ME-7001

- ▶ Build models that represent real life examples.
- ▶ Construct all three models concurrently with this set.
- ▶ Bring homework problems to life!

**Human Arm Model:** Students build a realistic arm model and directly measure the forces exerted by the biceps muscle (tension in supporting cord). Vary the length and angle of upper and lower arm, as well as the point of attachment of the muscle.

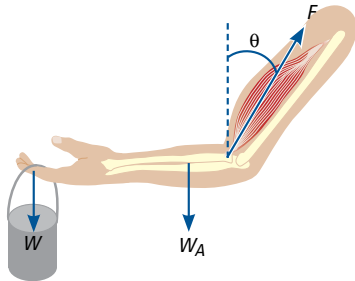

*Support Structure allows the angle of the upper arm to be easily adjusted.*

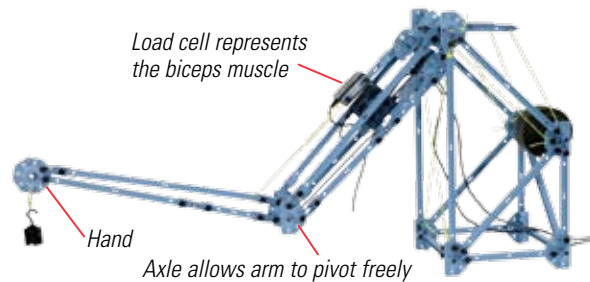

**Human Back Model:** Model the forces acting on a human back. Vary all parameters including position of back muscle attachment and angle of the torso. Directly measure the force exerted by the back muscles.

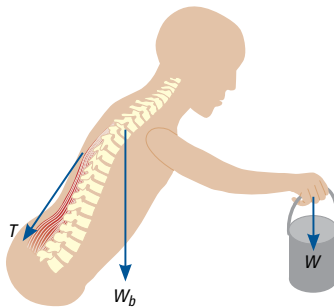

*Load cells directly measure forces exerted on back model.*

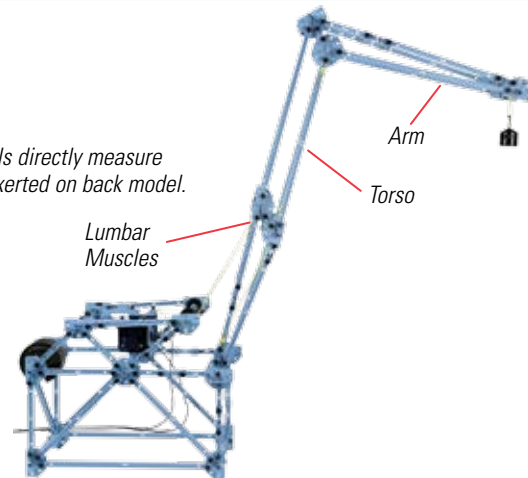

**Human Leg Model:** The leg model shown below uses a load cell for the quadriceps muscle to directly measure the force needed to support the leg at various angles.

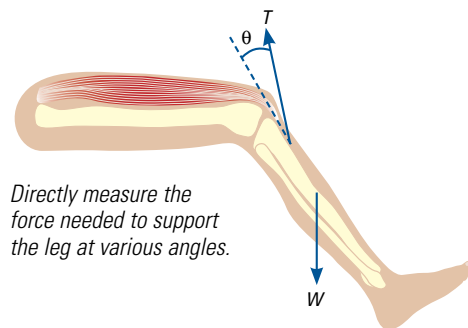
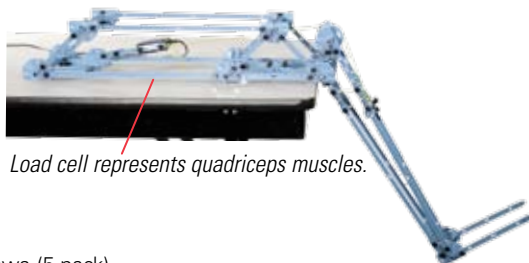

*Directly measure the force needed to support the leg at various angles.*

### Includes

- Truss Set Screws (5-pack)
- Truss Set Members (2-pack)
- Connector Spares (2-pack)
- One package each:
  - #6 I-Beam Spares
  - Cord Lock Spares
  - Axle Spares
  - Round Connector Spares
  - Angle Connector Spares
- Roll of rubber cord.

### Order Information

Human Structures Set.....ME-7001

*Shown in use with:*

Load Cell & Amplifier Set (includes four load cells).....	PS-2199	p. 32
Hooked Mass Set.....	SE-8759	p. 187
Large Slotted Mass Set.....	ME-7566	p. 187

## Structures Systems

## Hydraulic and Pneumatic Structures

ME-6984

Add a hydraulic/pneumatic ram to make your structures move and do work. Not only will students see the cranes and jacks in action, they can directly measure the pressure and volume to calculate how much work was done.

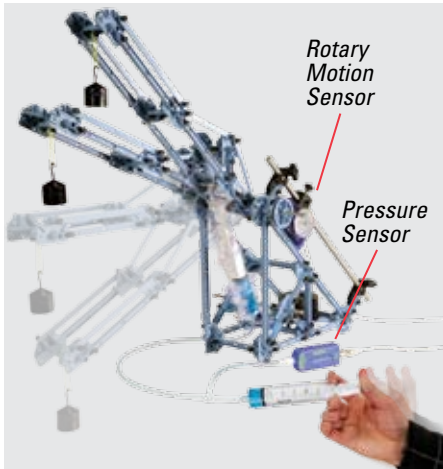

The weight is lifted using a syringe of water to fill the master cylinder. An Absolute Pressure Sensor measures the pressure and a Rotary Motion Sensor records the movement of the piston.



Pressure and volume are recorded as the weight is lifted, and the work done is the area under the curve.



## Includes

- Master Cylinder
- Pressure Sensor "T"
- Check Valves and Tubing
- Syringes (10, 20, 60 ml)
- Drive Belt for Rotary Motion Sensor (Not shown)

## Order Information

Hydraulic/Pneumatic Structures .....	ME-6984	
Advanced Structures Set .....	ME-6992B	p. 143
Steel Rod (45 cm) .....	ME-8736	p. 176
Absolute Pressure Sensor .....	PS-2107	p. 40
Rotary Motion Sensor .....	PS-2120A	p. 25

## Cast Beam Structures Set

ME-7009

Make your own cast beams which look like pre-stressed concrete beams. Test them and you'll find they perform like them, too. These beams are cast with a mixture of sand and plaster of Paris (not included). The rebar is made of the same plastic used for the I-beams. Students can explore how the strength of the beam is affected by the amount of tension put on the rebar, the mixture of sand and plaster of Paris, or using one or two rebar.

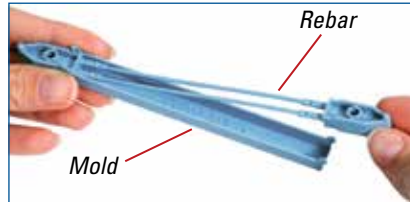

**Step 1:** The rebar with connecting ends snaps into the plastic mold.

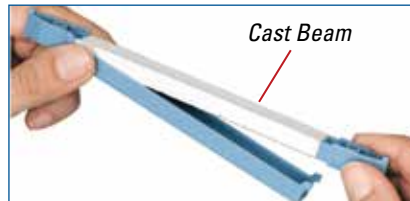

**Step 3:** After it dries, it is easy to remove the flexible plastic mold from the cast beam.



**Step 2:** Insert rebar into tensioning apparatus and pour a mixture of sand and plaster of Paris into the mold.

## Measure Young's Modulus for the rebar.

The connecting ends can be cut off from the rebar allowing the rebar to fit into the Material Testing Machine (ME-8236) with Flat Coupon Adapter (ME-8238).

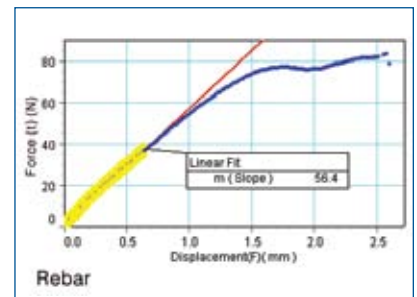

## Cast Beam Structures Set ME-7009 Includes

- I-Beam #5 (8) 24 cm long
- I-Beam #4 (18) 17 cm long
- I-Beam #3 (18) 11.5 cm long
- I-Beam #2 (8) 8 cm long
- I-Beam #1 (8) 5.5 cm long
- Axles (2 ea. of 3 lengths)
- Connectors (14)
- Cord Tensioning Clips (32)
- Round and Flat Connectors (6 ea.)
- PAstrack Fasteners (6)
- Angle and Straight Connectors (24 ea.)
- Collets (24)
- Screws (150)
- Pulleys, O-rings, Spacers (12 ea.)
- Sliding connector (12)
- Reusable Plastic Molds (10)
- Rebar (30)
- Yellow Cord (1 roll)
- Instruction Manual
- Required but not included:
  - Sand and Plaster of Paris



## Cast Beam Spares

ME-6983

Consumable replacement parts for Cast Beams. These can also be used with the Advanced Structures Set (page 170).

## Includes

- 10 Reusable Plastic Molds
- 30 Rebar with Connectors



## Order Information

Cast Beam Spares ..... ME-6983

## Order Information

Cast Beam Structures Set .....	ME-7009	
Also shown:		
Displacement Sensor .....	PS-2204	p. 33
Cast Beam Spares (Includes 30 rebar members, 10 cast beam molds with connectors) .....	ME-6983	
Large Slotted Mass Set .....	ME-7566	p. 187
Round Base with Rod .....	ME-8270	p. 177
60 cm Threaded Rod .....	ME-8977	p. 176

## Structures Flexible I-Beam

ME-6985

Use these flexible I-Beams to make a bridge that dramatically demonstrates how a bridge fails and yet the beams return to their original shape when the load is removed.



*Dramatically demonstrate structural failure*



### Includes

- Flexible I-Beam #5, 24 cm long (10)
- Flexible I-Beam #4, 17 cm long (18)
- Flexible I-Beam #3, 11.5 cm long (18)

### Order Information

Structures Flexible I-Beam .... ME-6985

Shown in use with:

Truss Set..... ME-6990 p. 141

## Mini Car Track Spares

ME-6974



Includes two gates, two track couplers and one bag (24) of roadbed clips.

### Order Information

Mini Car Track Spares ..... ME-6974

## Axle Spares

ME-6998A

Includes drive wheel with rubber tire (4), pulleys with "O" rings (12 each), axles (two each of three lengths), spacers (12) and collets (24).



### Order Information

Axle Spares..... ME-6998A

## Cord Lock Spares

ME-6996

Includes 32 cord-tensioning clips and a spool of yellow cord.



### Order Information

Cord Lock Spares..... ME-6996

Yellow Cord (2 pack)..... ME-9876

## Roadbed Spares

ME-6995

Mini Car Starter Bracket



Roller Coaster Track

Includes flexible roadbed (3 m), roadbed clips (24), car with flag, extra mass, mini car starting bracket, and track couples (2).

### Order Information

Roadbed Spares..... ME-6995

Sold Separately:

Roller Coaster

Track (9.1 m)..... ME-9814

## Force Platform Structures Bracket

ME-6988A

Includes two brackets and four screws.



### Order Information

Force Platform Structures Bracket ..... ME-6988A

## Truss Set Members

ME-6993

### Includes

- I-beam #5 (8) 24 cm long
- I-beam #4 (18) 17 cm long
- I-beam #3 (18) 11.5 cm long
- I-beam #2 (8) 8 cm long
- I-beam #1 (8) 5.5 cm long
- Connectors (14)

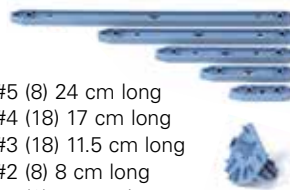

### Order Information

Truss Set Members ..... ME-6993

## Truss Set Screws

ME-6994

Includes 75 screws. All components in the Structures System use this same 6-32 thumb screw.



### Order Information

Truss Set Screws ..... ME-6994

## Structures Rod Clamps

ME-6986

Connects structure members to 1/2" rod. Includes a set of two.



### Order Information

Structures Rod Clamps (2) ..... ME-6986

## Beams

1. Thin I-Beams (ME-7012)



2. Flexible I-Beams (ME-6985)



3. Flat Beams (ME-6987)



4. #6 I-Beam Spares (ME-7008)



5. #5 I-Beam Spares (ME-7017)



6. Photoelastic Beams (ME-7011)



1. Includes Thin I-beam #4 (24) 17 cm long, Thin I-beam #3 (24) 11.5 cm long.

2. Includes Flex I-beam #5 (10) 24 cm long, Flex I-beam #4 (18) 17 cm long, and Flex I-beam #3 (18) 11.5 cm long.

3. Includes 16 each 2x3 beams 12 cm long, F4 beams 17 cm long, and 3x4 beams 19 cm long.

4. Includes 24 of the #6 I-beams, 35 cm long.

5. Includes 24 of the #5 I-beams, 24 cm long.

6. Includes Clear, Polycarbonate Thin I-beams #4 (24) 17 cm long, and #3 (24) 11.5 cm long.

### Order Information

Thin I-Beams ..... ME-7012

Flexible I-Beams ..... ME-6985

Flat Beams ..... ME-6987

#6 I-Beam Spares ..... ME-7008

#5 I-Beam Spares ..... ME-7017

Photoelastic I-Beams..... ME-7011

## Connectors

1. Connector Spares (ME-7002)

2. Angle Connector Spares (ME-6999A)

3. Round Connector Spares (ME-6997)



1. Set of 14 connectors used to join truss members.

2. Includes sliding connectors (12), angle connectors (24), and straight connectors (24).

3. Includes round connectors (6), flat connectors (6), and six bolts with nuts.

### Order Information

Connector Spares ..... ME-7002

Angle Connector Spares ..... ME-6999A

Round Connector Spares ..... ME-6997

# Materials Testing

## Comprehensive Materials Testing System

ME-8244

**With this one system, your students can investigate:**

- ▶ Compression and tensile testing
- ▶ Column buckling
- ▶ Three and Four-point bending
- ▶ Shear testing
- ▶ Stress lines with photoelasticity

System includes everything needed to study material testing; Testing Machine with attachments, test samples, and computer software. PASCO Capstone Workbooks include set-up instructions, theory, and detailed analysis questions.

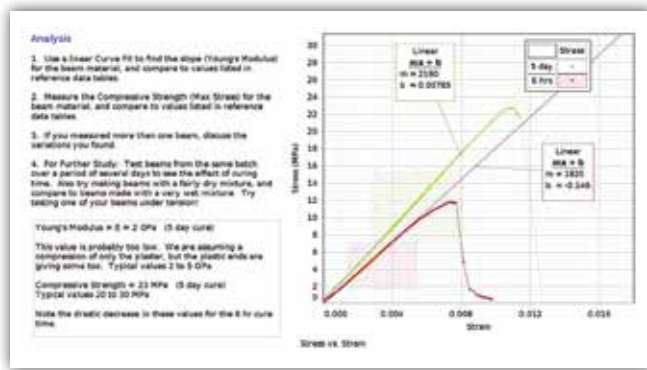

Clear Safety Shields

Materials Testing Machine

Tensile Samples

### System Storage Base

Sturdy plastic base provides convenient storage for accessories. Use a C-clamp on the corner of the base to temporarily secure the Materials Testing Machine to the lab bench.

Calibration Rod

Bending Support Anvil

Shear Accessory

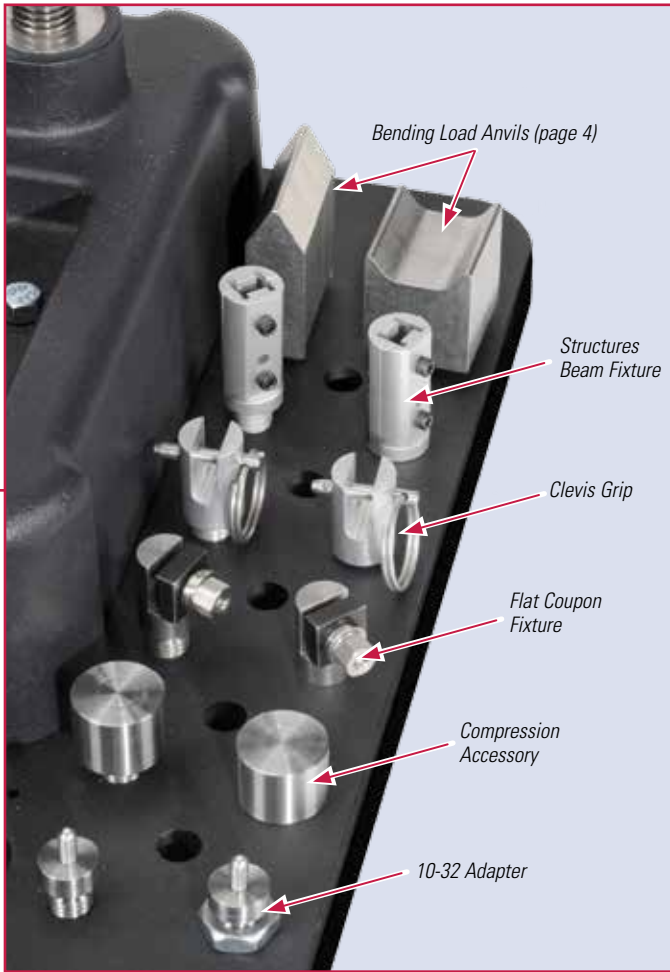

**Comprehensive Materials Testing System Includes:**

- ME-8236 Testing Machine (with Safety Shields and Calibration Rod)
- Tensile Samples (10 of each):  
ME-8231 Aluminum, ME-8232 Brass, ME-8233 Annealed Steel, ME-8243 Steel, ME-8234 Acrylic, ME-8235 Polyethylene
- ME-8237 Bending Accessory
- ME-8249 Four-point Bending Load Anvil
- ME-8241 Photoelasticity Accessory (with photoelastic beams)
- ME-8239 Shear Accessory (with Shear Samples)
- ME-8229 Storage Base
- ME-8242 Structures Beam Fixture
- ME-7012 Thin Beams
- ME-6983 Cast Spares
- ME-8247 Compression Accessory (with Compression Samples)
- ME-8238 Flat Coupon Fixture
- AP-8222 Plastic Flat Coupons
- AP-8223 Metal Flat Coupons
- ME-8245 Clevis Grip
- ME-8246 10-32 Adapter
- PS-2100A USB Link
- UI-5401 PASCO Capstone Software Single User License



**Order Information**

Comprehensive Materials Testing System.....	ME-8244
Materials Testing Machine.....	ME-8236

# Materials Testing

## Materials Testing Machine

ME-8236

- ▶ 7100 N max load
- ▶ Hand-cranked so students can feel samples break
- ▶ Inexpensive samples make it possible for each student to experience it first-hand

Measure force and displacement for various materials as they are stretched, compressed, sheared, or bent. Investigate material properties including Young's Modulus, Tensile Strength, Yield Strength, Ductility and Modulus of Resilience.

The Materials Testing Machine measures force with a 7100 N load cell and displacement with an optical encoder. It runs on PASCO Capstone software which has a built-in compliance calibration wizard and has all the tools to record and display stress vs. strain, apply linear fits to find Young's Modulus, and to record and play back webcam movies of the breaking samples, synced to the data. See page 74.

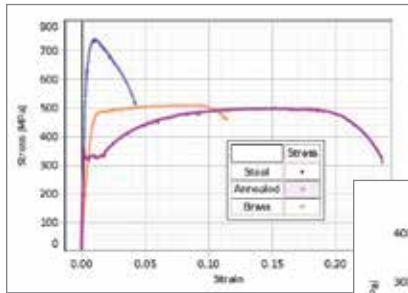

For annealed steel, a linear fit is applied to find Young's Modulus.

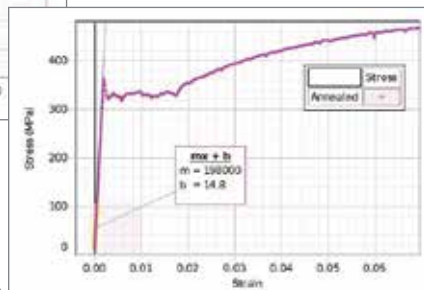

### Specifications

- Load cell capacity:** 7100 N (1600 lbs)
- Machine weight:** 20 lbs (9 kg)
- Footprint:** 24 wide x 25 depth x 51 cm height
- Lead screw length:** 38 cm
- Sturdy base:** cast aluminum
- Mounting holes:** for bolting to table

### ME-8236 Includes

- Machine
  - Compliance calibration rod
  - Safety shields
- (Requires Capstone software)

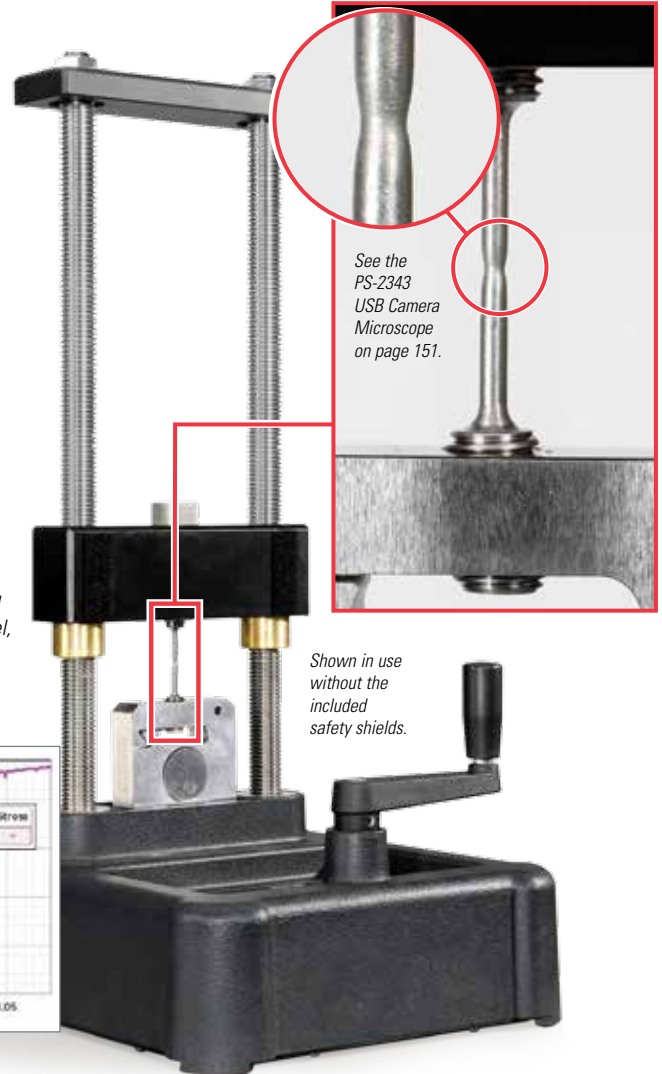

Tensile Samples (set of 10 each)  
Shown using tensile sample from Steel Set (ME-8243).



### Order Information

- Materials Testing Machine .....ME-8236
- Tensile Samples:
- Tensile Sample Aluminum (10).....ME-8231
- Tensile Sample Brass (10).....ME-8232
- Tensile Sample Annealed Steel (10).....ME-8233
- Tensile Sample Steel (10).....ME-8243
- Tensile Sample Acrylic (10).....ME-8234
- Tensile Sample Polyethylene (10).....ME-8235
- Required:
- PASCO Capstone Software.....pp. 18-20
- AirLink.....PS-3200

p. 10

Workbooks include all instructions needed to perform the experiment:

- ▶ Introduction and theory [Download FREE www.pasco.com/MaterialsTester](http://www.pasco.com/MaterialsTester)
- ▶ Set-up instructions
- ▶ Detailed analysis and summary questions

Speed Control

1. Click on Record and then turn the crank. Note that the Water Display at right shows you the rate that you are rotating (it is opening to the right-hand side, in increments of 100).

2. Practice turning the crank to raise the cross-head at a smooth, constant rate between 20 and 25 inches.

Tensile Strength

As the stretching process continues past the yield point, the sample is becoming that difficult to stretch. When stretching further leads to increase the stress and ultimately, fracture occurs in the necked region. The stretching process is now a plastic, that is, permanent deformation.

3. The Tensile Strength is the maximum stress on the graph. Measure and record the quantity for each sample.

4. The Ductility of the material is the maximum strain and before it broke. Measure and record the quantity for each sample. Note that this is usually expressed as a percentage.

5. The Modulus of Toughness for the material is the area under the Stress vs. Strain graph. Measure and record this quantity for each sample.

Material	Tensile Strength (MPa)	Ductility (%)	Toughness (MPa)
1. Steel	780	21%	26
2. Brass	520	23%	16
3. Annealed Steel	480	24%	12

Speed Control

1. Click on Record and then turn the crank. Note that the Water Display at right shows you the rate that you are rotating (it is opening to the right-hand side, in increments of 100).

2. Practice turning the crank to raise the cross-head at a smooth, constant rate between 20 and 25 inches.

Figure 2. Rotating Sample

Figure 3. Center Thread

Figure 4. Safety Shields

Figure 5. Alloy-Use Shield

## PASCO Capstone™ Software

Combining video with simultaneous data graphs is a very powerful tool.

- ▶ PASCO Capstone is data collection and analysis software which has a special built-in compliance calibration routine for the Materials Tester.
- ▶ It is shown here plotting a graph and recording a video, synced together, in real-time. Data analysis tools such as curve fits and area under the curve are available.
- ▶ With any of PASCO's interfaces, you can take advantage of the power of PASCO Capstone by using some of the 70+ sensors from PASCO.

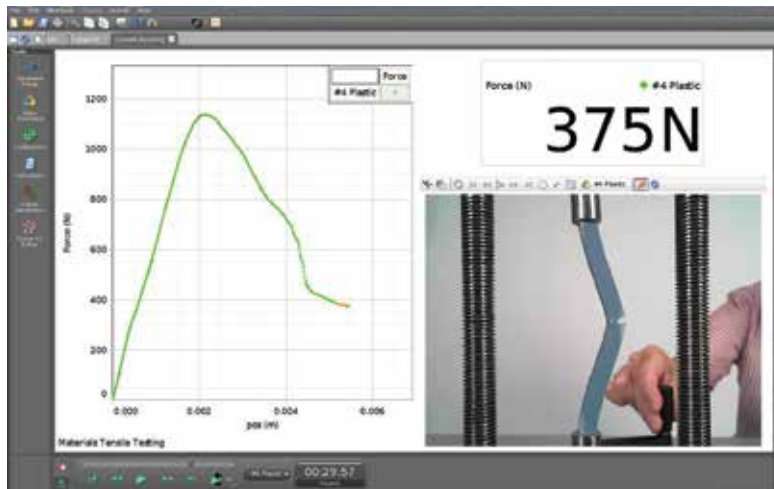

Enhance student understanding of the behavior of materials. PASCO Capstone software has the ability to embed live video from a webcam and sync the Materials Tester data to the recorded video. Then you can play back the video along with the data on the graph, stepping through one frame at a time to see the exact breaking point.

### Order Information

PASCO Capstone Software	
Single User License.....	UI-5401
Site License .....	UI-5400

Download PASCO Capstone Trial Version at [www.pasco.com/capstone](http://www.pasco.com/capstone)

## USB Camera Microscope

PS-2343

- ▶ Use as a web camera
- ▶ Optical zoom from 1x to 60x
- ▶ Built-in LED lighting

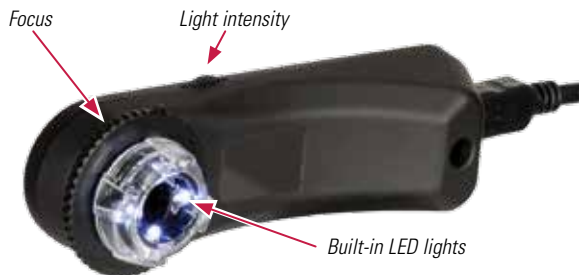

This versatile USB Microscope Camera can take pictures and video just like a digital camera, but it can also magnify like a microscope when it's up close to a specimen. And you can use it to take pictures showing lab setups, and document the appearance of materials before and after an experiment.

### How It Works

Use with the video and image capture features in PASCO Capstone. Magnification of specimens can be changed by adjusting the dial located on the front of the camera.



Image of broken steel tensile sample taken with the microscope.

As the tensile sample is being stretched, the force versus time data is graphed in sync with the movie.

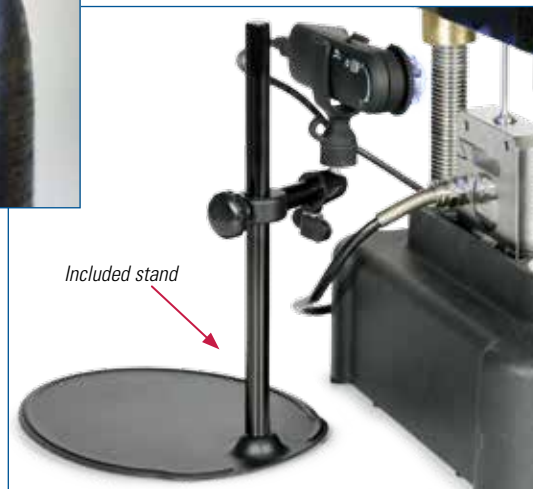

Included stand

### Includes

- Camera
- Microscope
- Stand

### Order Information

USB Camera Microscope.....	PS-2343
----------------------------	---------

# Materials Testing Accessories

## Photoelasticity Accessory

ME-8241

See stress lines by bending a clear, colorless photoelastic I-beam between two polarizing sheets. As the beam is bent, areas of greater stress show up as patterns of colored lines.

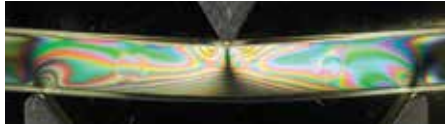

Photoelasticity Accessory consists of two crossed polarizing sheets which are placed in front of and behind the clear beam. When illuminated from behind by a bright white light, fringes due to the stress lines become visible.

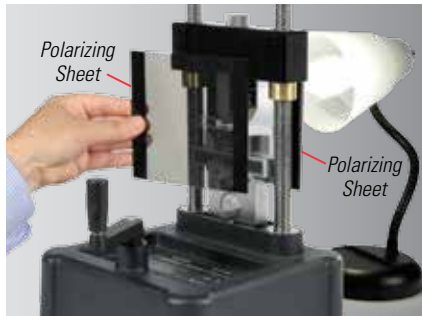

Lamp not included

### Includes

- Two polarizing sheets, 5 3/8" x 5 3/8" x 1/8"
- One Photoelastic I-beam Set (ME-7011)

### Order Information

Photoelasticity Accessory .....ME-8241  
 Photoelastic I-beam Set .....ME-7011  
 Shown in use with:  
 Bending Accessory .....ME-8237

## Materials Shear Accessory

ME-8239

Perform shear tests for a variety of wires. Accessory accepts diameters of 1/16", 3/32", 1/8", and 5/32". The Shear Accessory includes the ME-8240 Shear Samples, three each of 1/8" diameter, 12" long, aluminum, brass and mild steel.

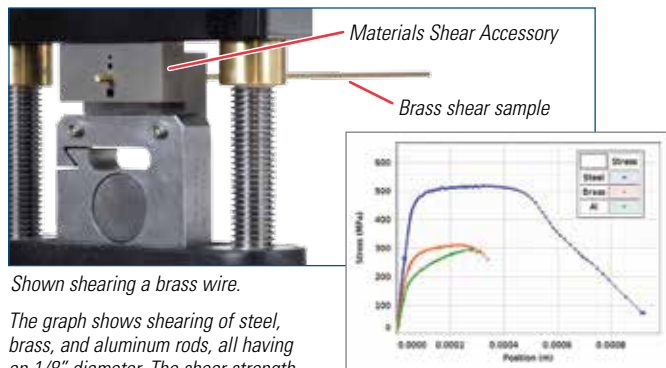

Shown shearing a brass wire.

The graph shows shearing of steel, brass, and aluminum rods, all having an 1/8" diameter. The shear strength of each material is measured.

### Includes

- Shearing Block and Shear Samples (ME-8240),
- 3 each of three types of wire.

### Order Information

Materials Shear Accessory .....ME-8239  
 Replacement Supplies:  
 Shear Samples (Set of 9) .....ME-8240

## Structures Beam Fixture

ME-8242

The Structures Beam Fixture allows any of the I-beams from PASCO's Structures System to be stretched or compressed in the Materials Testing Machine.

Find the critical load that causes the beam to buckle.

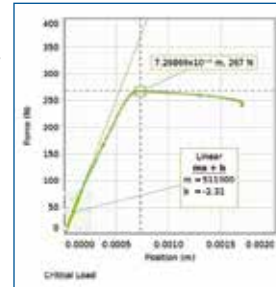

### Includes

- Clamps (2)



Plastic I-beam

Structures Beam Fixture

### Order Information

Structures Beam Fixture .....ME-8242

## Compression Accessory

ME-8247

This one-inch diameter platform provides a sturdy base to investigate compression of a variety of materials. It is shown here in a compression test on one of the included polyethylene test samples.

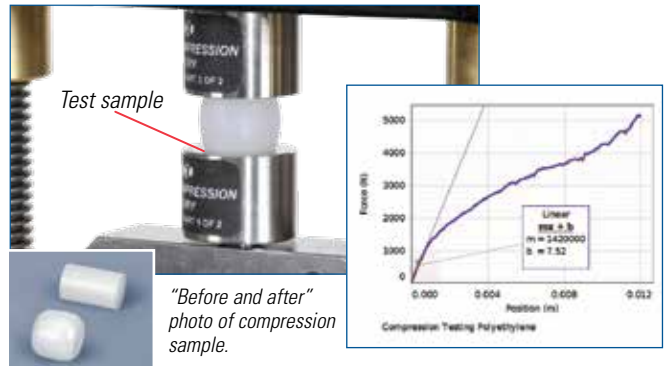

### Includes

- Platform
- 20 polyethylene cylinders (ME-8248), 1.3 cm dia. x 2 cm long.

### Order Information

Compression Accessory .....ME-8247  
 Replacement Supplies:  
 Compression Samples (20) .....ME-8248

## System Storage Base

ME-8229

The plastic base is made of High Density Polyethylene (HDPE). Includes base and mounting hardware.

### Order Information

System Storage Base .....ME-8229



## Bending Accessory

ME-8237

Perform three-point bending tests of various materials, including beams from the PASCO Structures System. Support anvils have adjustable separation up to 10 cm.



A Three-Point Bend test is performed on a brass rod from the ME-8240 Shear Samples. The support anvils have adjustable separation up to 10 cm.

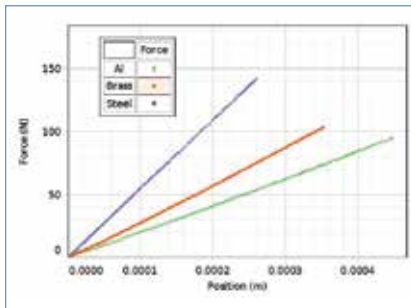

This Force vs. Position graph shows three-point bending for aluminum, brass, and steel samples, all with the same anvil spacing. From this graph, the flexural elastic modulus for each material is measured.

## Four-Point Bending Accessory

ME-8249

Add the optional Four-Point Bending Accessory to the ME-8237 to perform both three-point and four-point bending.

Perform a Four-Point Bend Test on the Cast Beams from the PASCO Structures System. Quantities measured include the Flexural Elastic Modulus and the Modulus of Rupture for the material.



### ME-8237 Includes

- Base
- Adjustable support anvil
- Load anvil

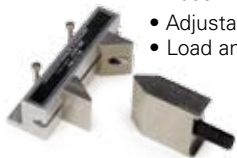

### ME-8249 Includes

- A two-point fixture which, when added to the Bending Accessory, allows four-point bending.



### Order Information

Bending Accessory .....ME-8237  
 Four-point Bending Accessory.....ME-8249

Shown in use with:

Shear Samples (set of 9) .....ME-8240  
 Thin I-Beams .....ME-7012  
 Cast Beams Spares.....ME-6983  
 (includes 30 rebar members, 10 cast beam molds)

## Flat Coupon Fixture

ME-8238

Test any flat material, such as paper, foil, or plastic. Shown using the Flat Plastic Test Coupons (AP-8222).

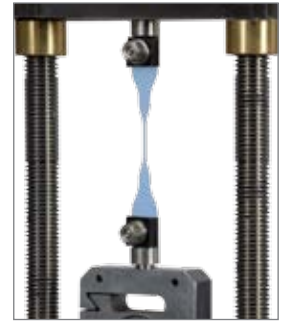

### Includes

- Clamps (2)
- Wrench (1)

### Order Information

Flat Coupon Fixture.....ME-8238  
 Plastic Test Coupons (40 coupons).....AP-8222 p. 154  
 Metal Test Coupons (50 coupons) .....AP-8223 p. 154

## Clevis Grip

ME-8245

This generic pin and clevis adapter allows the user to tensile test a wide variety of samples with hooked ends or through-holes. It is shown here testing an extension spring (not included).

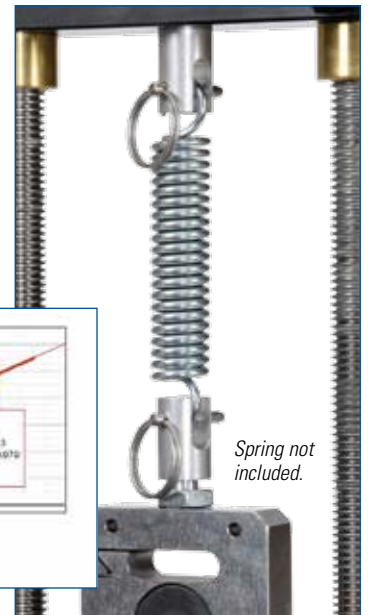

Spring not included.

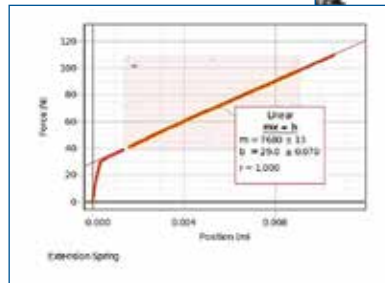

### Includes

- Clevis adapter and pin. Pin diameter is 0.187 in. Max width of sample is .300 in

### Order Information

Clevis Grip .....ME-8245

## 10-32 Adapter

ME-8246

Allows use of grips and attachments from other vendors that require a 10-32 male thread.

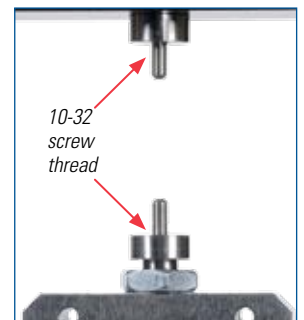

### Includes

- Upper and lower adapters.



### Order Information

10-32 Adapter .....ME-8246

## Materials Testing

### Looking for Tensile Samples for the legacy Stress/Strain Apparatus?



Although the AP-8214A Stress Strain Apparatus is obsolete, we will continue to supply the test coupons indefinitely to accommodate current users. These coupons are also useful in PASCO's new Materials Testing Machine (ME-8236). Please see pages 150-153 for this new Materials Testing Machine. There is a new adapter, the Flat Coupon Fixture (ME-8238), which allows these coupons to be tested in the new machine.

### Plastic Test Coupons

AP-8222



Four types of color-coded samples, 10 pieces per sample:

- High impact polystyrene (HIPS)
- Nylon 6 (15% glass fiber reinforced)
- Acrylonitrile butadiene styrene (ABS)
- Polypropylene (PP)

### Metal Test Coupons

AP-8223



Five types of samples, 10 pieces per sample (sample containers labeled with thickness in inches)

- Brass (thin) 0.003"
- Brass (thick) 0.005"
- Cold-rolled steel 0.003"
- Aluminum 0.003"
- Annealed steel 0.003"

#### Order Information

Replacement Plastic Test Coupons Full Set (40 coupons) ..... AP-8222  
Replacement Metal Test Coupons Full Set (50 coupons) ..... AP-8223

### Super-Flex I-Beam

ME-8987

- ▶ Demonstrate the difference in stiffness between the two directions of bending
- ▶ Show that I-beams twist easily
- ▶ Show torsion and buckling
- ▶ Grid shows deformation

This Super-Flex I-Beam is made of plastic, so it can be visibly bent by hand. It shows the basic reasons for using this cross-section in construction. It is four times as stiff in the upright orientation as it is sideways.



Column buckling



Demonstrate lack of torsional strength.

#### Includes

- Super-Flex I-Beam (24 inches long, 2 inches tall)
- Instructions



#### Order Information

Super-Flex I-Beam ..... ME-8987

### Matter Model

ME-9825A

The atoms of the Matter Model are brightly colored spheres with the bonds between the atoms modeled by springs, so that when forces are applied, the atoms can move in response.



Demonstrate the normal force response as a material is compressed.

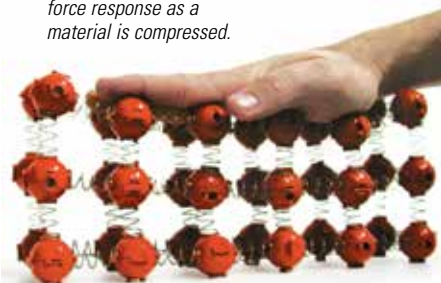

#### Includes

- Atoms (4.5 g each) (40)
- Heavy, light and long springs (60 each)
- Nuts (for increasing the atom mass) (30)
- 90 cm brass rod (for longitudinal waves)



The Matter Model is shipped in component pieces, ready for assembly.

#### Order Information

Matter Model ..... ME-9825A

## Equal-Length Spring Set

ME-8970

The five color-coded equal-length springs in this set have different spring constants: 25 N/m, 30 N/m, 35 N/m, 40 N/m, 50 N/m ( $\pm 5\%$ )



*The five color-coded springs stretch different amounts when a 1 kg mass is hung from each spring.*

These springs appear to be the same except for their colors. But, when equal masses are hung on them, each stretches a different amount. These extension springs are made of steel and are closed, requiring a slight initial force to separate the coils. The unstretched length of each spring is 30 cm and the approximate diameter is 1.4 cm.

These springs are supplied with a white storage box with cardboard separators to keep the springs from touching each other.

### Includes

- White storage box
- Five (color-coded) springs
- 30 cm long



### Order Information

Equal-Length Spring Set.....	ME-8970	
<i>Recommended:</i>		
Pendulum Clamp.....	ME-9506	p. 178
Hooked Mass Set.....	SE-8759	p. 187

## Series/Parallel Spring Set

ME-6842

The set of six springs consists of two each of three different spring constants. These springs are 15 cm long, half the length of the Equal-Length Spring Set, making it possible to combine two series short springs in parallel with one long spring.



*Shown in use with the Parallel Spring Bracket and the Hooked Mass Set.*

### Specifications

The six color-coded springs, two of each color, have different spring constants:

10 N/m, 20 N/m, 40 N/m ( $\pm 5\%$ )

### Includes

- White storage box
- Six (color-coded) springs 15 cm long



### Order Information

Series/Parallel Spring Set.....	ME-6842	
<i>Recommended:</i>		
Hooked Mass Set.....	SE-8759	p. 187

## Hooke's Law Spring Set

SE-8749



Includes three springs with the same diameter and length, but different spring constants. Three of each type of spring are included, and the springs fit nicely on PASCO mass hangers. All springs are 55 mm long and 7 mm in diameter. Spring constants are 5 N/m, 8 N/m and 70 N/m.

### Order Information

Hooke's Law Spring Set.....	SE-8749
-----------------------------	---------

## Parallel Spring Bracket

ME-6844

This unique bracket allows springs of different spring constants to be hung in series and parallel. The masses can be hung in an offset position to compensate for the stronger spring.

*Setup includes using the Demonstration Spring Set on page 156. Note the cm markings (see inset) on the Parallel Hook Bar. By calculating the applied torques, the relative forces from the two springs can be investigated.*

### Includes

- Suspension bracket
- Parallel hook bar

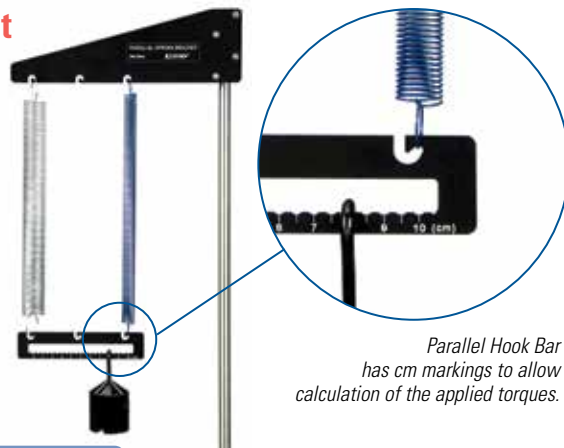

*Parallel Hook Bar has cm markings to allow calculation of the applied torques.*

### Order Information

Parallel Springs Bracket.....	ME-6844	
<i>Recommended:</i>		
Equal-Length Spring Set.....	ME-8970	
Series/Parallel Spring Set.....	ME-6842	
Hooked Mass Set.....	SE-8759	p. 187

## Springs

### Double-Length Slinky

SE-8760



The Slinky® is an excellent tool for demonstrating transverse and longitudinal wave phenomena. This Double-Length Slinky is twice as long as a traditional Slinky, allowing students to create well-defined wave pulses and standing wave patterns. The tension in the Slinky is very low, causing wave pulses to travel slowly throughout its length.

#### Order Information

Double-Length Slinky .....SE-8760

### Snakey

SE-7331



The extra-long metal spring is ideal for the study of mechanical waves. The Snakey has an unstretched length of 2 meters. Pull the convenient end loops more than 10 meters apart to demonstrate transverse, longitudinal, and standing waves.

#### Order Information

Snakey .....SE-7331

### Dynamics Track Spring Set

ME-8999



Includes 12 springs (1.6 cm diameter) with approximate spring constants of:

- 3.4 N/m (3 short and 3 long springs)
- 6.8 N/m (3 short and 3 long springs)

#### Order Information

Dynamics Track Spring Set (12) .....ME-8999

### Longitudinal Wave Spring

WA-9401



This spring has a 1.6 cm diameter and is 13.5 cm long. The approximate spring constant is 0.85 N/m.

#### Order Information

Longitudinal Wave Spring .....WA-9401

### Pendulum Clamp

ME-9506



*Hooks for springs*

Hang up to three springs or pendula. Suspension points are 54 mm apart.

#### Order Information

Pendulum Clamp .....ME-9506

### Demonstration Spring Set

ME-9866



This set includes four large springs for the demonstration of Hooke's Law or Conservation of Energy. Each spring is constructed of rugged spring steel with large loops for hanging from a pendulum clamp or stretching with hanging masses. Spring constants range from 4 N/m to 14 N/m. Spring lengths vary between 11 cm and 22 cm.



#### Order Information

Demonstration Spring Set .....ME-9866

*Recommended:*  
Pendulum Clamp .....ME-9506

Hooked Mass Set .....SE-8759 p. 187

## PASCO Stopwatch

ME-1234

- ▶ No alarm or clock
- ▶ Memory for stored event times
- ▶ Uses one AA battery
- ▶ Durable buttons

Are you tired of annoying stop-watch alarms going off all day? Are your students stuck in the clock mode and can't get their stop-watch back into the timing mode? Does your stopwatch stop working after changing that little watch battery? The PASCO Stopwatch solves all these problems!

This stopwatch was designed specifically for science timing. The modes of operation are intuitive and complete instructions are included. The buttons are built to last and it uses a single long-lasting AA battery, which is less expensive than a watch battery (and easier to install).

The PASCO Stopwatch fits comfortably in your hand.



The EVENT/RECALL button allows you to view the last time, in case students forget to write down their data. The EVENT/RECALL button is also used to store and recall up to nine event times. For example, record a series of events, such as times at which sandbags were dropped along the gym floor.

### Specifications

**LED Display:** Visible indoors and outdoors

**Two Display Modes:** MM:SS.SS (01:25.34) or Decimal Sec (85.34 s)

**Precision:** 0.01 sec up to 59:59.99 (MM:SS.SS) or 3599.99 s  
Then 1 sec to 99:59:59 (HH:MM:SS) or 359999 s

**Max Number of Event Times:** Nine

**Auto-off:** After one hour idle

Can Be Used with a Lanyard (not included)

**Includes:** AA battery and instruction sheet

### Order Information

PASCO Stopwatch ..... ME-1234

## PASCO Stopwatch (10 pack)

ME-1235

- ▶ Includes fitted foam storage box



### Order Information

PASCO Stopwatch (10 pack)..... ME-1235

## Pendulum Clamp

ME-9506



Hang up to three springs or pendula. Suspension points are 54 mm apart. Fits rods up to 16 mm (5/8 inch) in diameter.

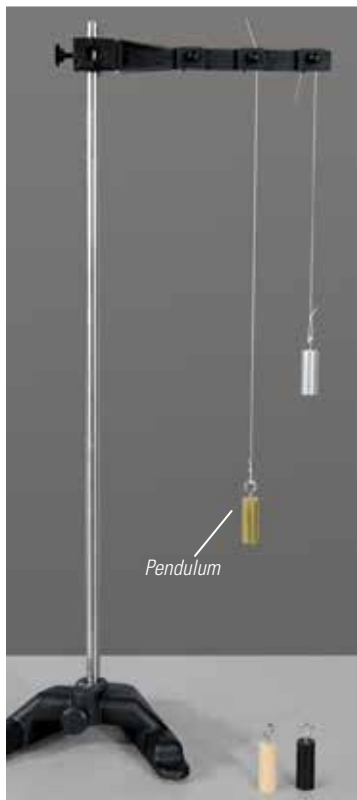

See page 146 for more information.



Easily adjust length of pendulum.

### Order Information

Pendulum Clamp ..... ME-9506

Shown in use with:

Photogate Pendulum Set ..... ME-8752  
Small "A" Base ..... ME-8976 p. 176  
Stainless Steel Rod (45 cm.) ..... ME-8736 p. 176

## Photogate Pendulum Set

ME-8752

- ▶ Great for classic pendulum experiments



The Photogate Pendulum Set is a unique set of four pendula that have the same shape and size, but different masses. Due to their cylindrical shape, these pendula are ideal for use in timing experiments with the photogate. One pendulum each of brass, plastic, wood, and aluminum is included.

### Typical Applications

- ▶ Determine relationship between period and mass
- ▶ Determine relationship between period and amplitude
- ▶ Determine relationship between period and length



Cylindrical shape allows easy calculation of the speed of the pendulum using the time it blocks the photogate. Photogate not included.

### Order Information

Photogate Pendulum Set ..... ME-8752

## Smart Gate

PS-2180



See page 36 for more information.

### Order Information

Smart Gate ..... PS-2180

# Rotation

## PASCO's Complete Rotational System

ME-8950A

- ▶ Most versatile rotational system available
- ▶ Stable, 4 kg cast iron base
- ▶ Dual, low-friction ball-bearings

The unit features a cast iron base, dual ball-bearings and stainless steel shaft. The moments of inertia are large enough to be sensed by the student when rotating the system by hand. Computer monitoring of angular velocity and a motorized drive are also possible.

PASCO's Complete Rotational System provides a range of experiments in centripetal force, angular momentum, and rotational motion. A unique set of accessories makes it an ideal tool for experiments in torques, friction, magnetic levitation, and Faraday's Law.



### Components of this system

1. Rotating aluminum platform with 4 kg cast iron base, dual ball-bearings, stainless steel shaft, three-step pulley, two rectangular sliding 300 g masses, and 50 cm track where a number of accessories may be mounted.
2. The Rotational Inertia Accessory with a 25.4 cm diameter, 1.50 kg disk (which may be rotated on two axes), a 12.7 cm diameter, 1.42 kg ring and Super Pulley with support rod and adapter.
3. The Centripetal Force Accessory with spring support and radius indicator, mass support, three masses, and Super Pulley with Clamp.

### Order Information

Complete Rotational System.....ME-8950A  
*Required:*  
 Mass and Hanger Set..... ME-8979 p. 187

### Interfacing Options

It is easy to use a computer to monitor rotational motion with the PASCO Rotational System. Here are two methods:

**1. The ME-9498A Photogate Head** mounts directly to the rotating platform base and measures angular speed. This works with the 850 and 550 Universal Interfaces. NOTE: PASPORT interfaces require a Digital Adapter (PS-2109).



### Order Information

*Recommended:*  
 Photogate Head .....ME-9498A p. 37

### 2. The CI-6538 or PS-2120 Rotary Motion

**Sensor** mounts to the base with an "A" Adapter and measures both angular speed and direction.



### Order Information

*Required for use with ScienceWorkshop:*  
 Rotary Motion Sensor ..... CI-6538 p. 28  
*Required for use with PASPORT:*  
 Rotary Motion Sensor ..... PS-2120A p. 25  
 "A"-base Rotational Adapter..... CI-6690 p. 169



### Included Experiments

1. Rotational Inertia of Disk and Ring - Two Axes
  2. Centripetal Force
  3. Rotational Inertia of Off-Axis Disk (fixed and rotating)
  4. Conservation of Angular Momentum, Using a Point Mass
- Experiments not shown:**
5. Rotational Inertia of a Point Mass
  6. Conservation of Angular Momentum, Projectile Version
  7. Conservation of Angular Momentum, Using Disk and Ring



*To see the experiments, type the product number into the search box at [www.pasco.com](http://www.pasco.com) and download the manual.*

Experiments you can do with this rotational system:

**Rotational Inertia of a disk and ring— 2 axes**

**“Center” axis**

With the disk mounted on the top of the vertical shaft, a torque is applied by a hanging mass. From the mass, the radius, and angular acceleration, the rotational inertia of the disk can be determined.

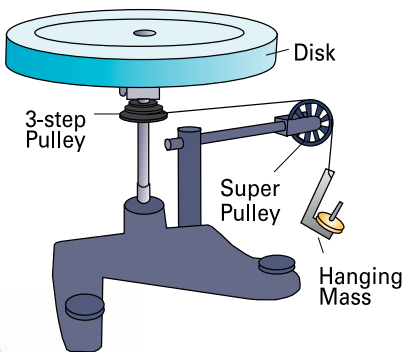

**Radial axis**

The disk can also be mounted on edge to decrease the rotational inertia by half.



**Rotational inertia of off-axis disk**

The rotational inertia adapter allows students to mount the disk anywhere along the platform. A bearing mounted on one side of the disk allows it to act either as a rigid mass or as a mass free to rotate around its point of attachment as the platform turns on the vertical shaft.



**Centripetal Force**

Centripetal force may be thoroughly investigated by varying both the mass and radius. The unique radius indicator allows students to continuously monitor the equilibrium position.

**Accurate Radius Indicator**

Can be monitored throughout the cycle of rotation.

**Mass Support**

Can be easily moved to change radius continuously from 2 to 20 cm.

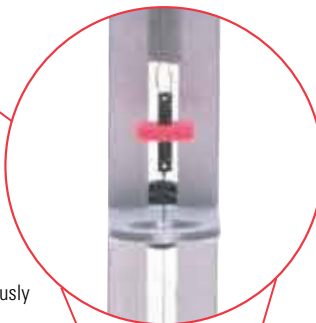

**Mass**

Easily changed to 100, 150, or 200 g.

**Spring Support**

Adjusts easily up and down to accommodate a continuous range of applied force.

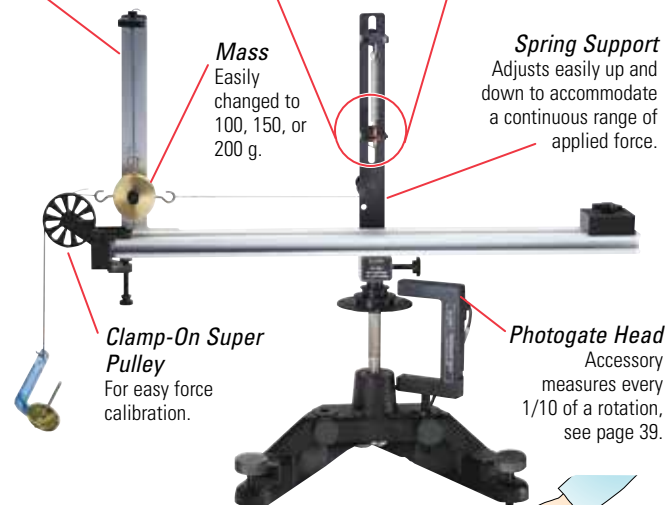

**Conservation of Angular Momentum**

Students can predict what will happen when a point mass rotating at a specific radius is pulled into a smaller radius. The rotational inertia of the mass at the inner and outer radii can be calculated and the results verified.

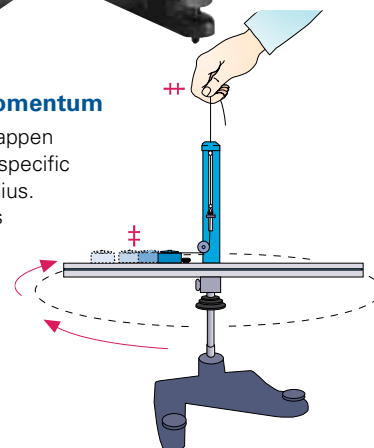

**Rotational System Components and Accessories Pages 160-161**



Rotating Platform and Rotational Inertia Accessory p. 160



Centripetal Force Accessory p. 160



Rotational Motor Drive p. 161



“A”-base Rotational Adapter p. 161



# Rotational System Components

## Rotating Platform ME-8951

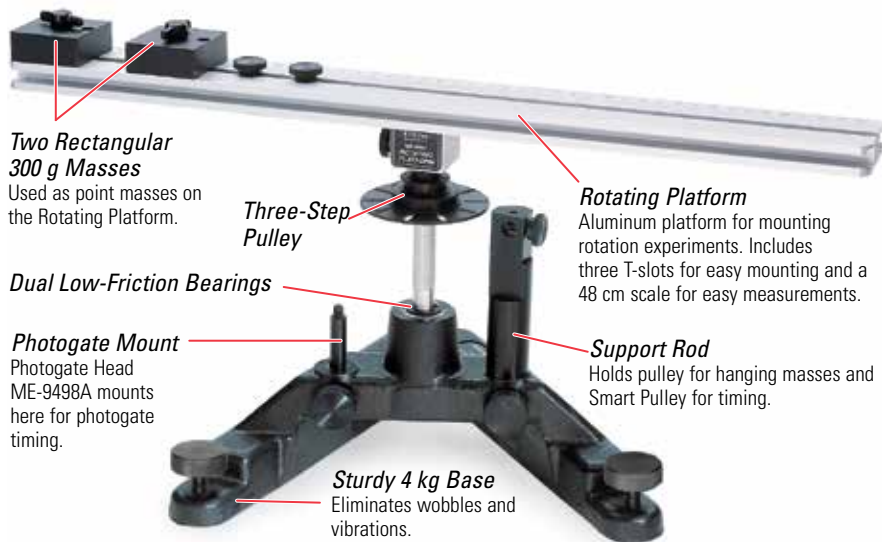

### Two Rectangular 300 g Masses

Used as point masses on the Rotating Platform.

### Three-Step Pulley

### Rotating Platform

Aluminum platform for mounting rotation experiments. Includes three T-slots for easy mounting and a 48 cm scale for easy measurements.

### Dual Low-Friction Bearings

### Photogate Mount

Photogate Head ME-9498A mounts here for photogate timing.

### Support Rod

Holds pulley for hanging masses and Smart Pulley for timing.

### Sturdy 4 kg Base

Eliminates wobbles and vibrations.

### A Versatile Base

The stable base and precision bearings of the Rotating Platform provide the foundation of PASCO's Rotational System. Serves as an excellent base for general rotation experiments.

### Order Information

Rotating Platform.....ME-8951

#### Recommended:

Rotational Inertia Accessory.....ME-8953

Centripetal Force Accessory.....ME-8952

Rotational Motor Drive.....ME-8955

p. 161

## Centripetal Force Accessory

ME-8952

With traditional centripetal units, the ability to change the variables is either impossible or limited. The PASCO Centripetal Force Accessory is designed to make changing the mass, radius, or force quick and easy.

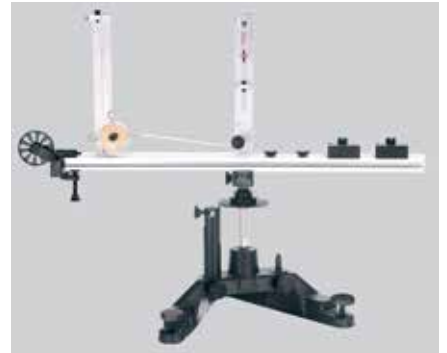

### Features

#### ► Vary Parameters Independently:

Change the centripetal force, mass, and radius independently of each other.

#### ► Change Variables Over a Wide Range:

Radius can be varied continuously from 2 to 20 cm, and the rotating mass can be 100, 150, or 200 g.

#### ► Observe the Radius Indicator

**Throughout the Cycle:** PASCO's design has the indicator at the center of rotation, allowing continuous observation throughout the rotation cycle, which results in more accurate measurements.

## Rotational Inertia Accessory

ME-8953

A disk and a ring permit several experiments in rotational inertia. The disk may be rotated about several axes. When used in conjunction with the adapter, experiments using the parallel-axis theorem may be performed by moving the disk off from the center of rotation. The ball-bearing on one side of the disk permits it to rotate freely for some experiments, while a "D" hole on the other side prevents rotation about the disk axis.

### Includes

- Heavy-Grade Plastic Disk (25.4 cm diameter, 1500 g)
- Metal Ring (12.7 cm outside diameter, 1420 g)
- Disk Adapter
- Super Pulley and Support Rod



### Plastic Disk

25.4 cm diameter, 1500 g.

### Holes

for rotation on "vertical" axis.

### Center Hole

has ball bearing on one side.

### Super Pulley

and support rod.

### Adapter

to mount disk to rotating platform at any radius.

### Metal Cylinder

12.7 cm diameter, 1420 g



### Includes

1. Spring Support and Radius Indicator Assembly
2. Mass Support
3. Masses (100 g and two 50 g)
4. Super Pulley with Clamp

### Order Information

Centripetal Force Accessory.....ME-8952

## Rotational Motor Drive

ME-8955

The Motor Drive is used with the Rotational Platform to power continuous rotational motion demonstrations. Use this motor to drive the Rotational Acceleration Tank at a constant speed. Power the Motor Drive with a ramp function using the DC Power Supply to smoothly increase the angular speed of the Centripetal Force Accessory. The motor requires a 12 V DC power supply or a function generator.



Easily change the gear ratio of the motor drive by moving the drive belt to one of the three possible pulley steps.

### Specifications

**Motor:** 12 V maximum, 0.2 A minimum

**Base Spindle Speed Range:** 10 to 600 rpm

**Three-Step Pulley**

### Includes

- Motor
- 3-Step Pulley
- Drive Belt



### Order Information

Rotational Motor Drive.....	ME-8955	
<i>Required:</i>		
Rotating Platform .....	ME-8951	p. 160
850 Universal Interface .....	UI-5000	p. 12-13
<i>or</i>		
Function Generator.....	PI-8127	p. 238
<i>or</i>		
DC Power Supply .....	PI-9880	p. 231

## "A"-base Rotational Adapter

CI-6690

The "A"-base Adapter allows students to mount a Rotary Motion Sensor to obtain high resolution data. One revolution of the vertical shaft corresponds to one revolution of the Rotary Motion Sensor, giving 4000 data points per revolution for the Rotary Motion Sensor.

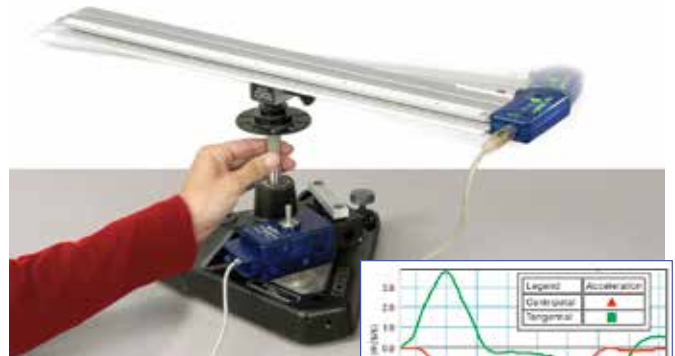

The platform is quickly rotated (from rest) and then brought to a stop. Both the tangential and centripetal acceleration is measured (using the 2-Axis Acceleration Sensor), while the platform's angular velocity is measured by the Rotary Motion Sensor.

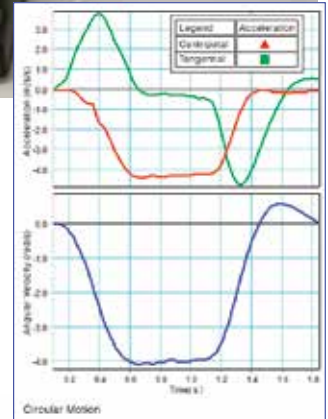

Close-up of Rotary Motion Sensor mounted on "A"-base.



### Includes

- Rotary Motion Sensor Mounting Post
- O-Ring Drive Belt
- Three-Step Pulley
- Pulley Mounting Screw



### Order Information

"A"-base Rotational Adapter.....	CI-6690	
<i>Required:</i>		
Rotating Platform .....	ME-8951	p. 160
Rotary Motion Sensor ScienceWorkshop.....	CI-6538	p. 25
<i>or</i>		
Rotary Motion Sensor PASPORT .....	PS-2120A	p. 25

# Rotational System Components

## Centripetal Force Apparatus

ME-8088

- ▶ Empirically determine centripetal force
- ▶ Easy to set up ▶ Repeatable results

### Features

- ▶ **Stable Frame:** The metal frame can be easily attached to a ring stand using the included clamp. The frame may also be attached to a tabletop with a large table clamp.
- ▶ **High Quality Motor:** Will withstand years of student use.
- ▶ **Computer-based Measurements:** The Force Sensor and photogate facilitate accurate and repeatable measurements of force, angular velocity, and tangential velocity.

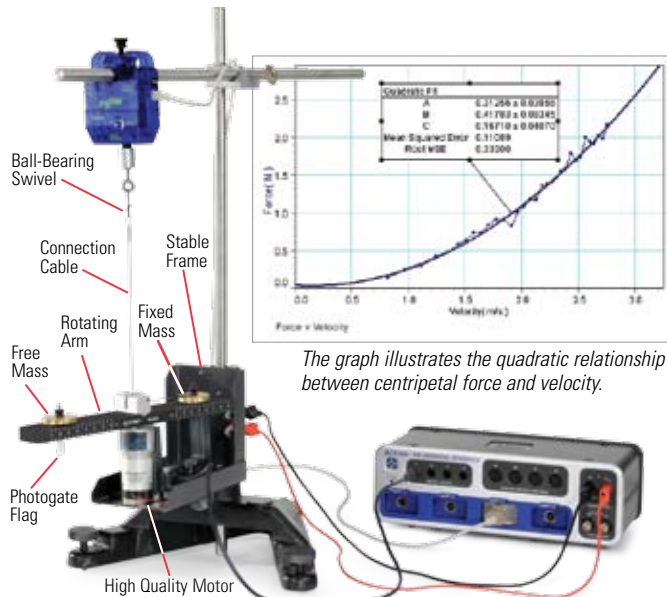

The graph illustrates the quadratic relationship between centripetal force and velocity.

### How It Works

The rotating arm features a groove with two captured masses along its length. One of the masses is free to move along the length of the groove. The free mass is connected to a small cable that runs under a pulley in the center of the arm and up to a Force Sensor. A ball-bearing swivel is used to ensure the cable does not tangle as the arm rotates. The other mass is placed the same distance from the center as the free mass, thereby balancing the arm. A flag attached to the bottom of the fixed mass passes through the photogate once per revolution, allowing a calculation to be made of the angular and tangential velocity of the mass.

### Includes

- Frame with Mounted
- 12 VDC Electric Motor
- Connecting Cable
- Ball-Bearing Swivel
- Connecting Hardware for Photogate
- Mass Holder for Free Mass
- Mass Holder for Fixed Mass
- 5 g Mass (2)
- 10 g Mass (2)
- 20 g Mass (2)



### Order Information

Centripetal Force Apparatus.....	ME-8088
<i>Required:</i>	
Force Sensor .....	pp. 28-29
Photogate Head .....	p. 37
Triple Output Power Supply .....	SE-8587 p. 233
Large Rod Base .....	ME-8735 p. 176
45 cm Steel Rod .....	ME-8736 p. 176
120 cm Steel Rod .....	ME-8741 p. 176
Multi Clamp .....	ME-9507 p. 178

## Wireless Centripetal Force Accessory

ME-8094

- ▶ Transmitting data wirelessly eliminates friction
- ▶ Uses Wireless Force Acceleration Sensor
- ▶ Vary speed, radius, and mass

The Wireless Centripetal Force Accessory is a low friction sliding mass holder that connects to a Wireless Force Acceleration Sensor (PS-3202). When installed on a Rotating Platform (ME-8951), it provides a simple and direct measurement of centripetal force and acceleration. Vary the mass using the holed masses in the Mass and Hanger Set (ME-8979). The string length is easily adjusted to vary the radius.

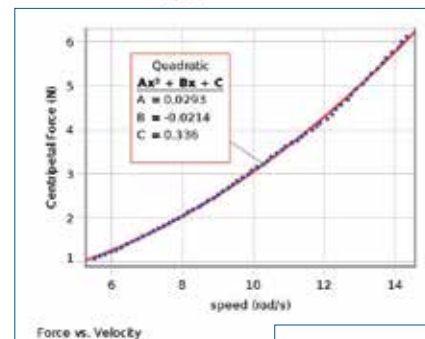

This PASCO Capstone graph shows the Centripetal Force (measured directly by the Wireless Force Acceleration Sensor) versus Angular Speed as the platform slows down.

In this PASCO Capstone graph, a "QuickCalc" of speed squared has been chosen on the horizontal axis, resulting in a straight line.

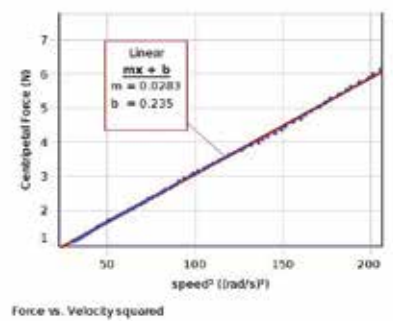

### Includes

- Low friction sliding mass holder
- Mounting post for force sensor

### Order Information

Wireless Centripetal Force Accessory .....	ME-8094
<i>Required:</i>	
Wireless Force Acceleration Sensor .....	PS-3202
Mass and Hanger Set .....	ME-8979
Rotating Platform .....	ME-8951
PASCO Capstone .....	pp. 18-20

## Hand-Held Centripetal Force

### Discover Centripetal Force Kit

ME-9837A



Motion Sensor detects stopper on each rotation and is used to calculate its speed.

As the stopper is swung around in a circle by hand, the Force Sensor directly measures the centripetal force. This hand-held method allows students to feel the centripetal force.

Use the traditional method with hanging masses, or use with a Force Sensor to continuously measure the centripetal force. Adding sensors to this classic experiment creates a dynamic, quantitative lab that your students will never forget!

#### Includes

- Rubber Stoppers (sizes 6, 8, 10)
- Plastic Ties (10)
- Yellow String (73 meters)
- Hollow Tube



#### Order Information

Discover Centripetal Force Kit .....	ME-9837A	
<i>Shown in use with:</i>		
High Resolution Force Sensor .....	PS-2189	p. 28
Motion Sensor .....	PS-2103A	p. 24
<i>Required for Classic Approach:</i>		
Hooked Mass Set .....	SE-8759	p. 187
Stopwatch .....	ME-1234	p. 116

## Flying Pig

SE-6655

This classic centripetal force experiment is used in high school AP® Physics 1 curriculum. Hang from the ceiling, give it a push, and it flaps its wings as it “flies” in a circle.



#### Order Information

Flying Pig (US only) .....	SE-6655
<i>Required:</i>	
2 AA Batteries (not included)	

## Centripetal Force Pendulum

ME-9821

- ▶ Quantitative force vs. velocity data
- ▶ Repeatable results
- ▶ Vary pendulum length and mass

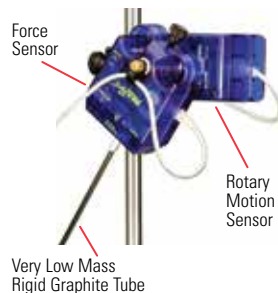

When used with Force and Rotary Motion Sensors, the Centripetal Force Pendulum allows students to collect accurate circular motion data.

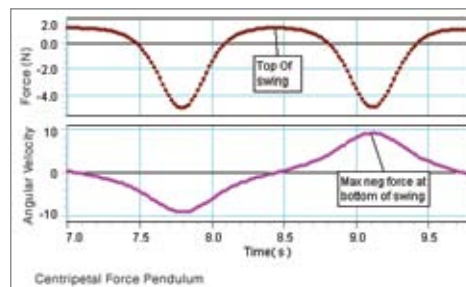

The Centripetal Force Pendulum is used to produce graphs of force and angular velocity versus time. Note that the force changes direction at the top of the swing for large amplitudes.

The Centripetal Force Pendulum attaches to a Force Sensor and allows students to directly measure the forces involved in circular motion. By attaching the Force Sensor/pendulum combination to the Rotary Motion Sensor, the relationship between force, mass, and velocity in a circular path can be investigated.

#### Includes

- Graphite Pendulum Rod with Threaded Connector
- Sliding Mass (100 g)
- Mount with Cord Clip



#### Order Information

Centripetal Force Pendulum .....	ME-9821	
<i>Required:</i>		
Large Rod Base .....	ME-8735	p. 176
45 cm Steel Rod .....	ME-8736	p. 176
90 cm Steel Rod .....	ME-8738	p. 176
Multi Clamp .....	ME-9507	p. 178
<i>Also required for use with ScienceWorkshop:</i>		
Rotary Motion Sensor .....	CI-6538	p. 25
Economy Force Sensor .....	CI-6746	p. 28
<i>Also required for use with PASPORT:</i>		
Rotary Motion Sensor .....	PS-2120A	p. 25
Force Sensor .....	PS-2104	p. 28

## Rotational Inertia

### Rotational Inertia Set

ME-9774



Release two different sized objects simultaneously.

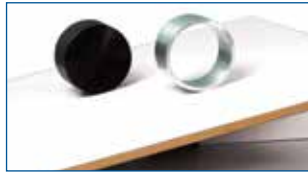

#### How It Works

Compare rotational inertias of objects with different shapes and sizes. Students learn that the speed of an object rolling down the ramp is not affected by its mass or radius. The shape or distribution of the mass determines the outcome. The sphere will reach the bottom first, followed by the disk. The ring will be last.

#### Includes

- 10 cm outer diameter set
  - Solid Sphere (810 g)
  - Ring (Aluminum, 230 g)
  - Disk (Plastic, 370 g)
- 5 cm outer diameter set
  - Solid Sphere (110 g)
  - Ring (Aluminum, 90 g)
  - Disk (Plastic, 70 g)
- Release Mechanism



#### Order Information

Rotational Inertia Set.....ME-9774

### Spherical Mass Set

ME-8968



This set includes four balls with a diameter of 25 mm each, but featuring various masses and rotational inertias.

#### Typical Applications

- ▶ Race the hollow steel ball and solid aluminum ball down an incline. They have about the same mass, but the solid aluminum ball has a much larger acceleration down the ramp.
- ▶ Fire the yellow plastic, solid steel, and hollow steel balls from a PASCO Short- or Long-Range Projectile Launcher.

#### Includes

- Solid Yellow Nylon Ball (10 grams)
  - Solid Steel Ball (66 grams)
  - Hollow Steel Ball (21 grams)
  - Solid Aluminum Ball (24 grams)
- (release mechanism not included)



#### Order Information

Spherical Mass Set.....ME-8968

### Rotational Inertia Wands

ME-9847

The red and blue wands have the same mass but the red wand is easier to rotate because the red wand has less rotational inertia.

These two wands have the same mass and the same dimensions and yet the red wand is easier to rotate. This is because the red wand has two metal slugs near its center, while the blue wand has two similar metal slugs at its ends. This demonstrates that rotational inertia depends on the distribution of the mass.

These sturdy plastic wands have small holes near the center and at the ends to enable students to see where the metal is located in each wand. So that what initially seems a mystery can be explained to the students by allowing them to examine the wands more closely.



To demonstrate the difference in rotational inertia of the two rods, ask two students to grab the center of a wand and instruct them to rotate the wand back-and-forth as rapidly as they can. No matter how strong the student with the blue wand is, he or she is not able to rotate it as fast as the student with the red wand.

#### Specifications

**Length:** 1 m

**Diameter:** 4 cm

**Ratio of Blue Rotational Inertia to Red:** Approx. 6

#### Includes

- Red Wand (1)
- Blue Wand (1)



#### Order Information

Rotational Inertia Wands.....ME-9847

## Mini Rotational Accessory

CI-6691

Add the Mini-Rotational Accessory to the Rotary Motion Sensor to study the oscillations of a pendulum, the rotational inertia of an aluminum disk, a steel ring and a metal rod, as well as the conservation of momentum during a rotational collision. The clamp-on Super Pulley allows students to apply a torque by hanging a mass over the pulley.

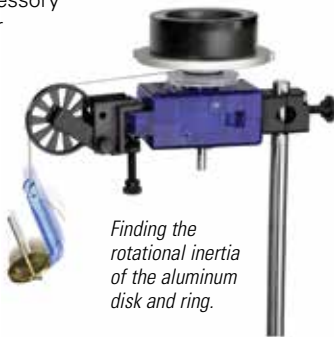

Finding the rotational inertia of the aluminum disk and ring.



Finding the rotational inertia of point masses using the graph of angular velocity vs. time.

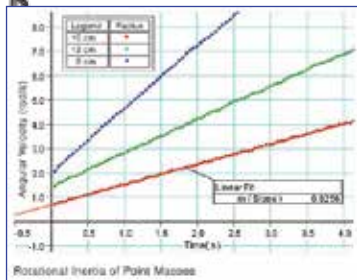

## Coupled Pendula

Couple two pendula with a rubber band and plot the position vs. time for each pendulum. The result is a vivid example of energy transfer between the pendula.

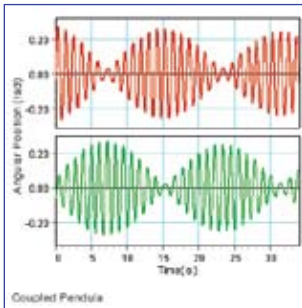

## Large Amplitude Pendulum

See page 335 for complete experiment.

By placing one mass on each end of the tube, the pendulum will oscillate slowly. Students will have time to view the motion of the pendulum, while also watching the real-time graph of displacement, velocity, and acceleration versus time. The period can be measured as a function of the amplitude of the pendulum and compared to theory.

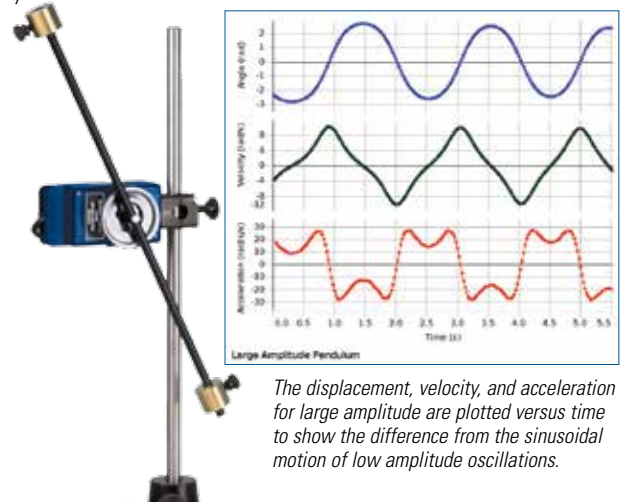

The displacement, velocity, and acceleration for large amplitude are plotted versus time to show the difference from the sinusoidal motion of low amplitude oscillations.

## Conservation of Angular Momentum

See page 334 for complete experiment.

To demonstrate conservation of angular momentum, a non-rotating ring is dropped onto a rotating disk. The angular velocity of the disk is recorded in real-time, and students can easily determine the angular velocities of the disk just before and after the ring is dropped. Combining these velocities with the rotational inertia of the disk and ring, students can confirm that angular momentum is conserved.



The angular speed of the disk decreases when the ring is dropped onto the spinning disk.

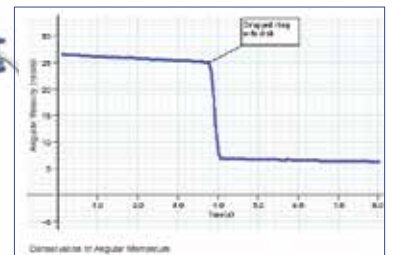

## Pendulum Accessory

ME-8969

The pendulum rod and masses can be purchased separately.

### Includes

- 38 cm Pendulum Rod (27 g)
- 75 gram Mass (2)



### Order Information

Pendulum Accessory.....ME-8969

### Includes

- Rotating Disk (9.5 cm diameter, 120 g)
- Large Ring Mass (7.6 cm o.d., 5.4 cm i.d., 465 g)
- 38 cm Pendulum Rod (27 g)
- 75 gram Mass (2)
- Clamp-On Super Pulley



### Order Information

Mini Rotational Accessory.....CI-6691

# Rotational Motion Accessories

## Physical Pendulum Set

ME-9833

This set of six objects is perfect for studying Physical Pendula, Moments of Inertia, and the Parallel Axis Theorem. Each piece fastens directly to a Rotary Motion Sensor to measure the objects acceleration due to an applied torque, or the period when the pendulum freely oscillates.

Each piece is made from 1/4 inch thick aluminum plate.

The Pendulum Bar has holes spaced at 2 cm intervals. A graph of oscillation period vs. pivot hole position shows that there is a unique placement that gives a minimum period. This location can be verified using calculus.

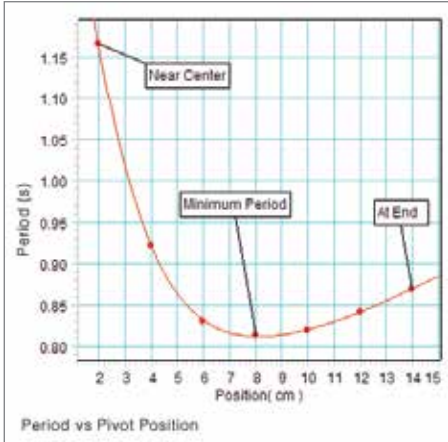

Apply a known torque and measure the angular acceleration to calculate the moment of inertia of the object. Multiple holes in the plate allow investigation of the Parallel Axis Theorem.



Unique design allows pivot exactly at the edge. Measure the period of the thick ring oscillating at either the inner or outer radius.

### Includes

- Solid Disk
- Thick Ring
- Thin Ring
- Offset Hole
- Pendulum Bar
- Irregular Shape
- Six mounting screws



### Order Information

Physical Pendulum Set.....	ME-9833	
<i>Shown in use with:</i>		
550 Universal Interface.....	UI-5001	p. 14
Rotary Motion Sensor.....	PS-2120A	p. 25
Base and Support Rods.....		p. 176
Super Pulley with Clamp.....	ME-9448B	p. 137
Mass and Hanger Set.....	ME-8979	p. 187

## Chaos/Driven Harmonic Accessory

CI-6689A

The Chaos/Driven Harmonic Accessory allows students to study the behavior of a physical pendulum in either harmonic or chaotic motion. The disk mounts to a Rotary Motion Sensor, allowing PASCO Capstone™ to monitor and plot the pendulum's angular position and velocity.

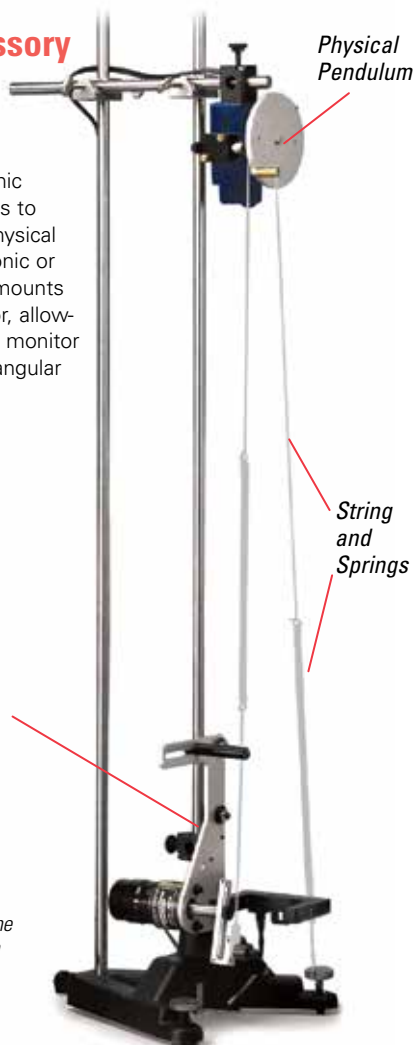

A sinusoidal force is applied to the disk and spring system in the Chaos/Driven Harmonic Motion experiments.

### 1. Chaotic Motion

Chaotic oscillations of the physical pendulum are produced by adjusting the magnetic damping, driver amplitude, and driver frequency.

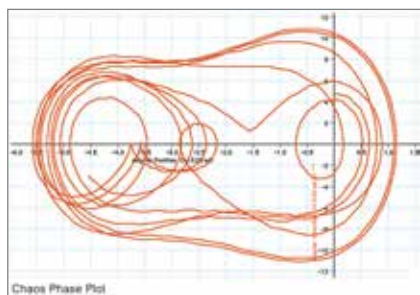

This phase plot (angular velocity vs. displacement) shows chaotic movement of the disk.

This Poincaré plot shows the pendulum's velocity versus position only once per period of the driving force. The gray background is the phase plot.

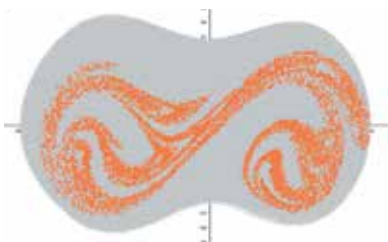

### 2. Driven Harmonic Motion

As a 10 cm aluminum disk is driven by a mechanical oscillator, two Rotary Motion Sensors simultaneously monitor the position of the disk and driver. The bidirectional sensors resolve to 1°, so the computer can easily display amplitude, frequency, and phase.

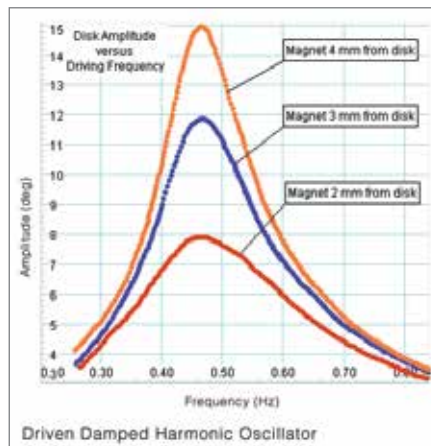

Angular velocity vs. frequency graph shows effects of magnetic damping on amplitude of resonance peak.

### 3. Damped Pendulum

The Rotary Motion Sensor graphically monitors the damped oscillations of an aluminum disk. A movable magnet allows students to change the strength of magnetic damping.

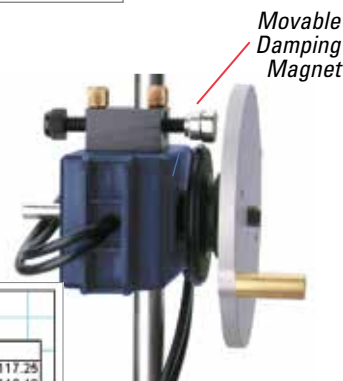
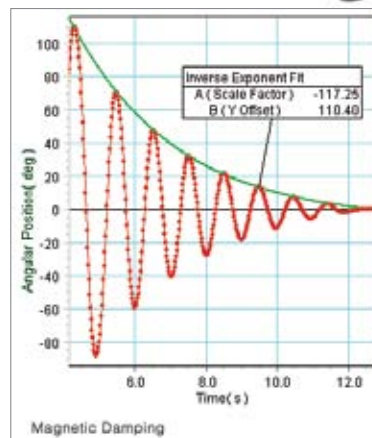

A turn of the screw moves the magnet away from or closer to the physical pendulum.

#### Includes

- Rotating Disk (9.5 cm diameter, 120 g)
- Eccentric Mass (15 g)
- Springs
- Adjustable Magnet for Damping



#### Order Information

Chaos/Driven Harmonic Accessory .....CI-6689A

For more information, see Driven Damped Harmonic Oscillator Experiment EX-5522A on page 322 and Chaos Experiment EX-5523A on page 323.

## Gyroscope

## Gyroscopic Motion

## Demonstration Gyroscope

ME-8960

- ▶ All Components Accessible
- ▶ Excellent Demonstration Tool
- ▶ Precision Angle Indicator

The unique low friction and open design of PASCO's Gyroscope allow studies of rotational motion never before possible with a commercial unit. The completely open design lets students stop precession by grabbing the vertical shaft and observing that the gyroscope dips. Rotational mathematics predicts the dipping action, but it could never be confirmed with traditional enclosed units.

## How It Works

The disk is spun by wrapping a string around the pulley and pulling. Or the disks can be spun by hand. Add mass to either end of the gyroscope and it responds with a predictable precession. Many features make this an exceptional demonstration tool for rotational motion concepts.

## Features

- ▶ **Low Friction:** The disk takes almost 6 minutes to slow to half of its original speed due to low-friction bearings in the gyroscope axle and vertical shaft.
- ▶ **Accurate Angle Indicator:** Measures from  $30^\circ$  to  $140^\circ$  and is easily read to the nearest degree. A retractable stop acts as a marker during experiments.
- ▶ **Easy Timing:** Low rotation speeds allow measurement of angular speed by counting revolutions and using a stopwatch.
- ▶ **Easy Balancing:** Two counterweights allow coarse and fine balance adjustment.
- ▶ **Large Inertia Disk:** With the large rotational inertia of the disk, PASCO's gyroscope generates precession rates similar to smaller, enclosed gyroscopes. The slow rotation speed of PASCO's disk lets students study fast as well as slow precession and use a stopwatch to make measurements.

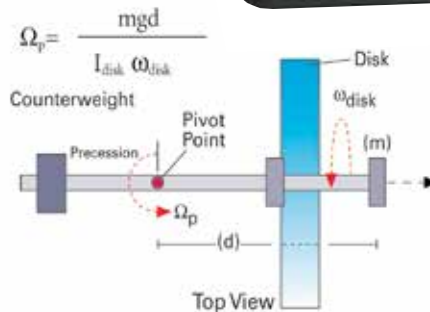
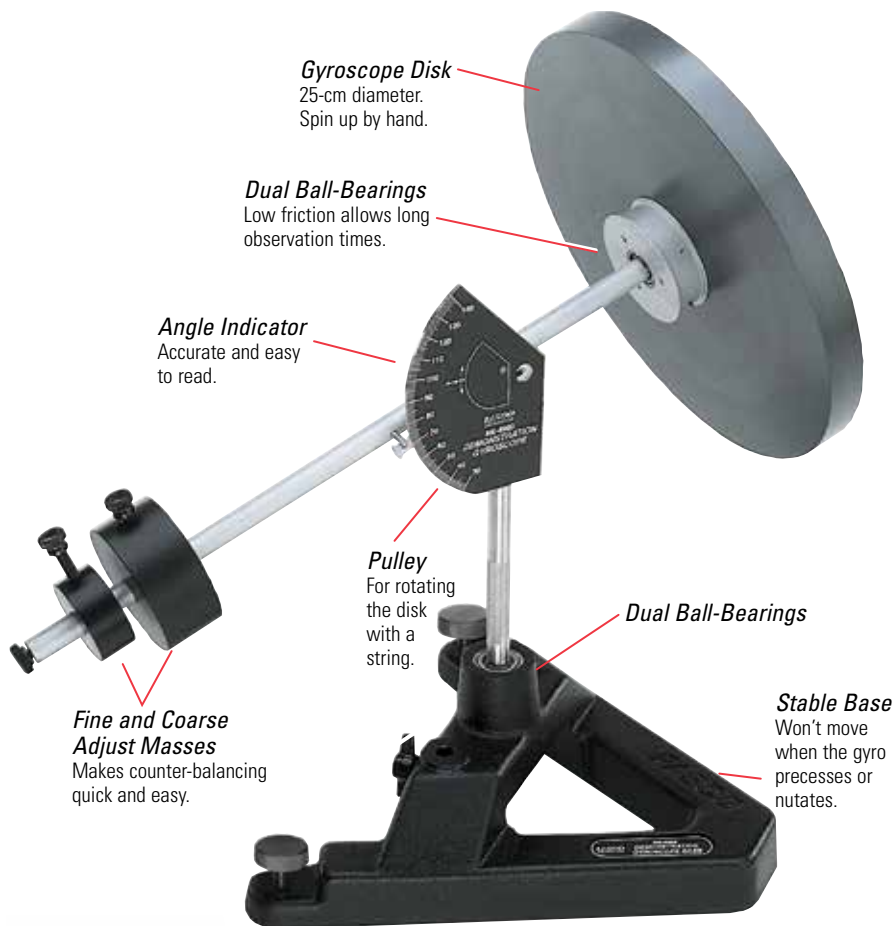

Students can determine the rotational inertia of the rotating disk. They can then check the measured precession rate when a mass ( $m$ ) is added a distance ( $d$ ) from the pivot point.

## Order Information

Demonstration Gyroscope ..... ME-8960  
 Recommended:  
 Accessory Disk and Mass ..... ME-8961

**Accessory Disk**  
 Add a second disk spinning in same or opposite directions.

*A Unique Experiment: Rotate two disks in opposite directions at the same speed. The angular momenta cancel and the total angular momentum of the gyroscope is zero. The result—no precession.*

## Accessory Disk and Mass

ME-8961

## Includes

- Accessory Disk
- Extra Counter Mass

## Order Information

Accessory Disk and Mass ..... ME-8961

## Sensor Mounting Accessories

With two Rotary Motion Sensors, the Mounting Bracket, and the "A"-base Rotational Adapter, the Demonstration Gyroscope becomes a quantitative instrument for advanced rotational motion experiments.

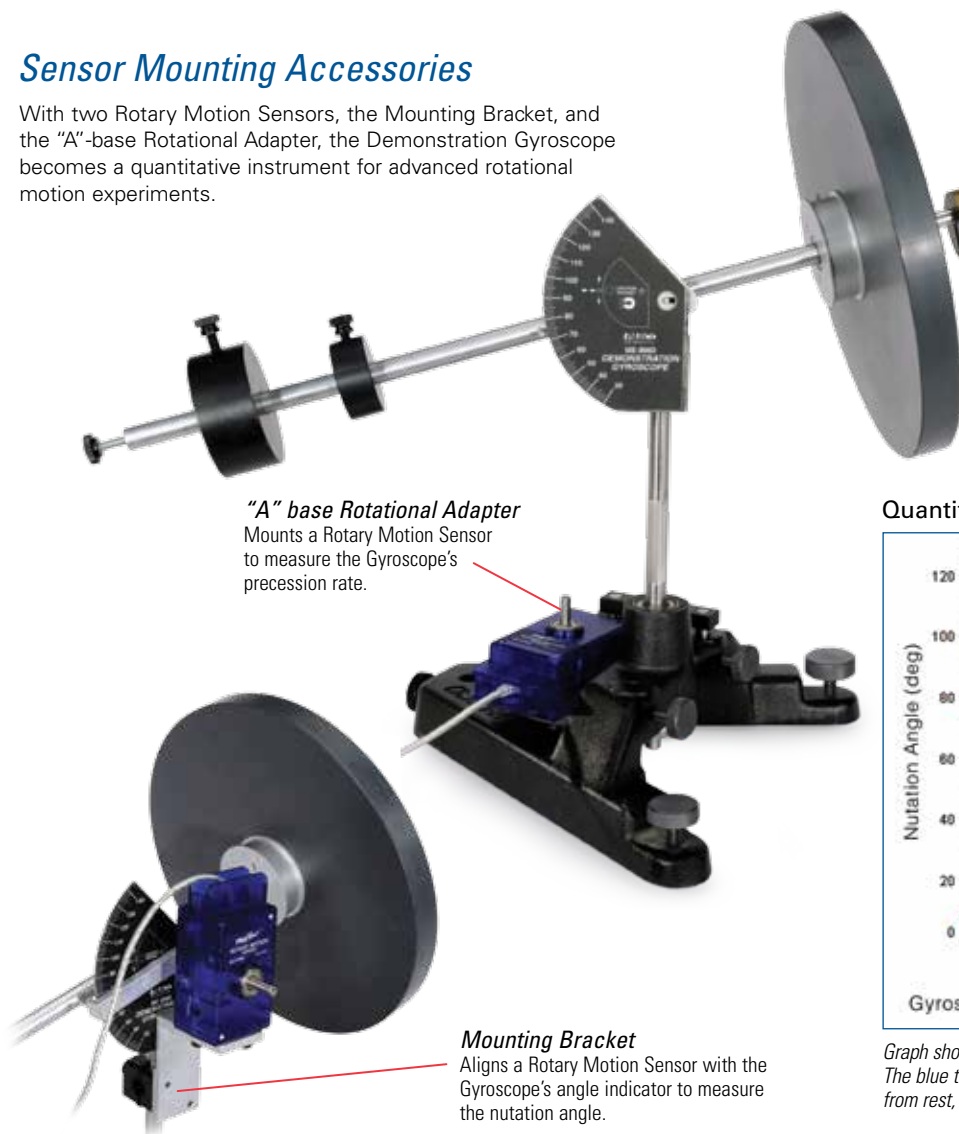

**Brass Mass**  
Adds known torque to cause precession.

**"A" base Rotational Adapter**  
Mounts a Rotary Motion Sensor to measure the Gyroscope's precession rate.

**Mounting Bracket**  
Aligns a Rotary Motion Sensor with the Gyroscope's angle indicator to measure the nutation angle.

### Quantitative Measurements

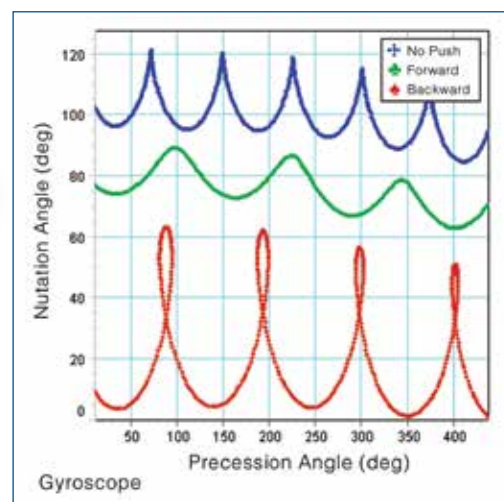

Graph shows nutation pattern for three cases:  
The blue trace results when Gyroscope is released from rest, with no initial push forward or backward.

## Rotary Motion Sensor/Gyroscope Mounting Bracket

ME-8963

With the Mounting Bracket and the "A"-base Rotational Adapter (CI-6690), the Demonstration Gyroscope becomes a quantitative instrument for advanced rotational motion experiments. With two Rotary Motion Sensors, students obtain a graphical picture of the Gyroscope's nutation and precession motions.



### Order Information

*For Recording Nutation Data:*

Rotary Motion Sensor/Gyroscope Mounting Bracket.....ME-8963

*Required:*

Rotary Motion Sensor ..... p. 25  
Interface ..... p. 10-11

## "A"-base Rotational Adapter

CI-6690

Mounts a Rotary Motion Sensor to the base to monitor the Gyroscope's precession rate.



### Order Information

*For Recording Precession Data:*

"A"-base Rotational Adapter.....CI-6690

*Required:*

Rotary Motion Sensor ..... p. 25  
Interface ..... p. 10-11

## Gyroscope

## Bicycle Gyroscope

ME-6837

- ▶ Solid 1/2" steel shaft
- ▶ Cushioned hand-grips
- ▶ Precision ball-bearings for low friction
- ▶ Non-marking rubber tire

The newly redesigned Bicycle Gyroscope is perfect for getting your students engaged in understanding rotational motion. Unlike other bicycle gyroscopes, the PASCO model is extremely rugged for years of use, but also lightweight at just 6 lbs. Cushioned hand-grips, a pull-cord with handle, and an included suspension cord (for demonstrating precession) make it simple and easy to use.

*Precision ball-bearings result in extremely low-friction for both the Bicycle Gyroscope and the Rotating Chair.*

*Non-marking Rubber Tire*



*This 2.8 kg (6 lb.) Bicycle Gyroscope has a solid 12.7 mm (1/2") steel shaft with cushioned hand-grips.*

*Attach cord (included) to hole in handle to demonstrate precession.*



*The Bicycle Gyroscope with the Rotating Chair gives you a perfect demonstration of the conservation of angular momentum.*



*Use the included pull-cord with handle to spin up the wheel.*

## Includes

- Bicycle Gyroscope
- Two Cords with Handles



## Order Information

Bicycle Gyroscope ..... ME-6837  
 Shown in use with:  
 Rotating Chair ..... ME-6856

## Bicycle Gyroscope Mass Set

ME-6972

Adding all four of the masses adds 1.6 kg to the wheel's (approximate) 2.8 kg mass and increases its rotational inertia by over 60%.

*Mass securely clamps to the wheel rim using included screws.*



## Includes

- Four 400 g masses

## Order Information

Bicycle Gyroscope Mass Set ..... ME-6972  
 Required:  
 Bicycle Gyroscope ..... ME-6837

## Rotating Chair

ME-6856

Rugged design and incredibly low friction make this far superior to any office chair.

*Sturdy 45 cm diameter rotating platform can be used with or without included chair. Wrap rope around groove to apply torque.*



*Steel base*

## Includes

- Chair
- Rotating Platform with Leveling Feet



## Order Information

Rotating Chair ..... ME-6856  
 Shown in use with:  
 Photogate Head ..... ME-9498A

## Atmospheric Pressure Demonstrator

ME-8966A

Demonstrate the effect of a pressure differential. Easily lift a box or stool by simply placing the rubber sheet on a smooth surface of the object and lifting up on the handle.

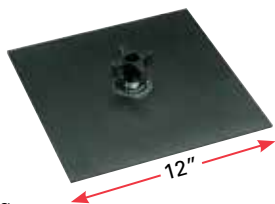

As you pull up on the handle, a low-pressure region is created.

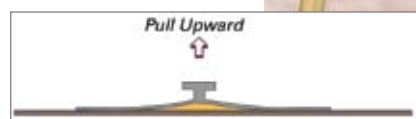

### Order Information

Atmospheric Pressure Demonstrator .....ME-8966A

## Air Cannon

SE-7370

The Air Cannon uses a vortex of air for ammunition. Its unique shape creates a stable toroidal vortex. Pull back the flexible membrane, release, and the invisible wave front of air can hit a target 20 feet away! A great demonstration of the energy that can be stored in waves.

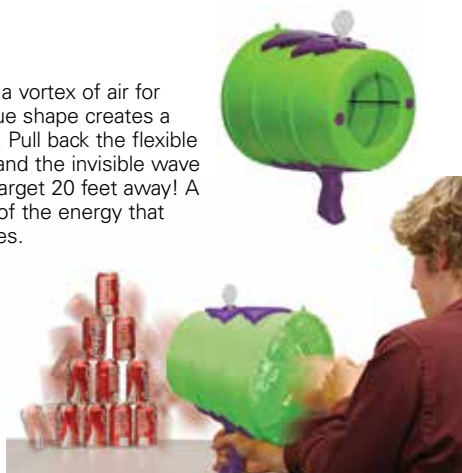

### Order Information

Air Cannon .....SE-7370

## Student Bell Jar

SE-9790



This bell jar provides a vacuum chamber for students to perform many experiments including:

- ▶ Watching a balloon expand or warm water boil as air is pumped from the chamber.
- ▶ Observing that a suction cup no longer sticks when the jar is evacuated.



Water boils as air is evacuated from the Bell Jar.

### Includes

- 8 cm x 6 cm dia. clear plastic bell jar with base
- Plastic vial, balloons and suction cup
- 60 cc syringe and valves for evacuating the jar



### Order Information

Student Bell Jar .....SE-9790

## Magdeburg Plates

SE-9717A

These two plates are a modern and versatile rendition of a classic demonstration.

Air is evacuated using a syringe; no vacuum pump needed. Clear plastic design lets students see everything. Two different "O" rings allow two different size areas. Tubing is provided so students can connect a Pressure Sensor for use with DataStudio.



### Includes

- 10.7 cm diameter circular polycarbonate plates (2)
- O-rings (2) (8.5 cm and 5.4 cm diameter)
- 60 cc syringe
- Connecting tubing with one-way valve and inline connector for optional Pressure Sensor

### Order Information

Magdeburg Plates .....SE-9717A

## Pipe Network

**Pipe Network:** *Build it your way and instrument it inexpensively.*

- ▶ Instrument your pipe network with pressure and flow sensors
- ▶ Transparent Venturi Tube and pressure taps
- ▶ Study head loss in pipes, fittings, and valves
- ▶ Find the relationship between pump head and flow rate

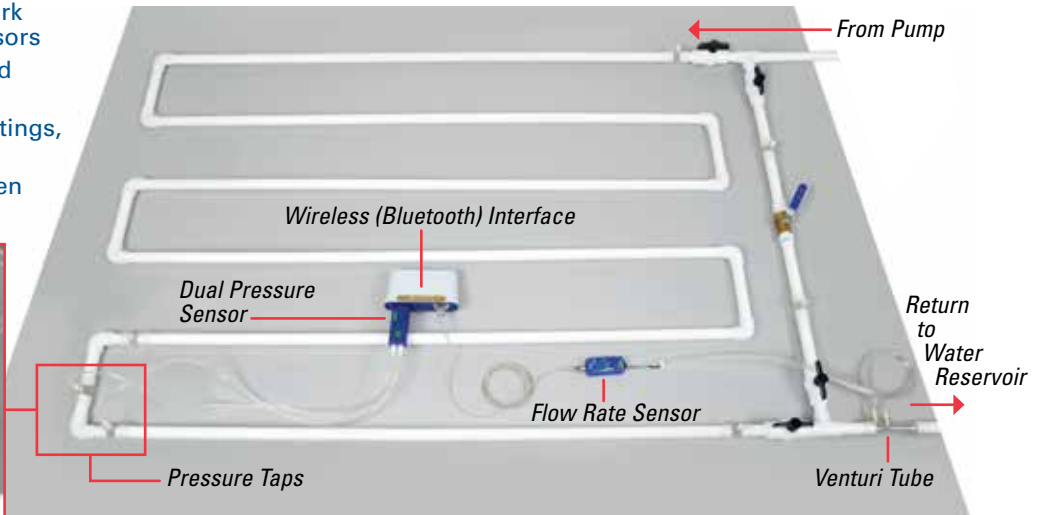

### Measure pressure

In constructing a pipe network, it is useful to know the pressure in the fluid at numerous places along the pipe. The transparent Pressure Taps can be glued into a 3/4" PVC pipe network at any place, using a slip joint. Each Pressure Tap has a quick-connect for a Dual Pressure Sensor (PS-2181). Since the quick-connect closes when disconnected, it is possible to move the pressure sensor around the network to determine the pressures at different positions, rather than having a separate pressure sensor for each position.

### Measure flow rate

The General Flow Sensor measures the difference in fluid pressure between the two different cross-sectional areas and the software does a calculation to convert this pressure difference into a velocity or volumetric flow rate. The Venturi Tube slip joints are designed to be glued into any 3/4" PVC pipe network. The Venturi Tube is made of clear PVC so the water can be seen flowing through it. It has a constriction and two pressure ports with tubing attached. The Venturi Tube is connected to the General Flow Sensor (PS-2225) by the matching couplers.

### Create pump curves

Create a plot of pressure versus flow rate for a pump and determine the maximum head and flow rate. Study how these change when two pumps are connected in series or parallel.

### Portable interface

Use the SPARKlink Air (PS-2011) with a Dual Pressure Sensor (PS-2181) as a great portable pressure measurement system. The SPARKlink Air has two PASPORT sensor ports and can accommodate a General Flow Sensor to measure the volume flow rate and a Dual Pressure Sensor to measure the pressures along the pipe.

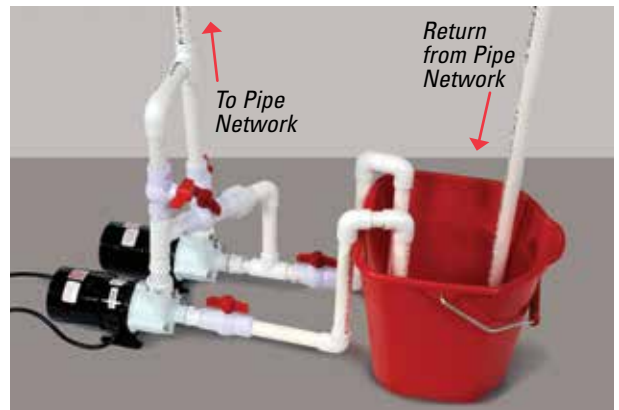

*Study one pump or two pumps in series and parallel.*

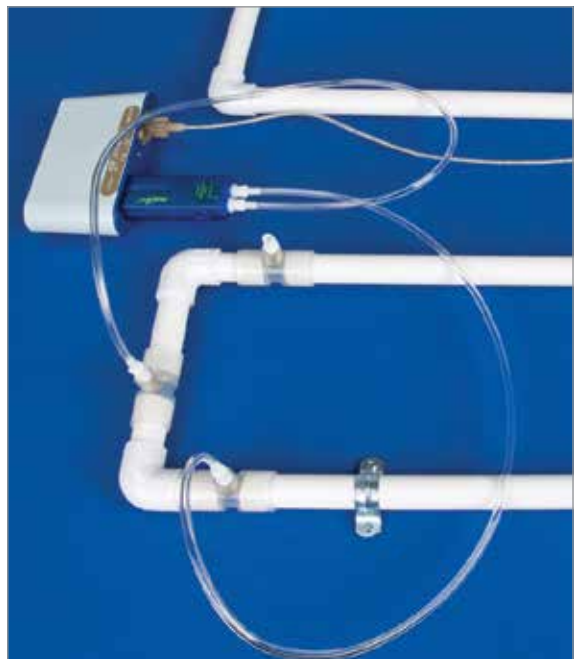

*Pressure Taps are installed before and after elbow joints to measure the pressure loss. The Venturi Tube measures the velocity.*

## General Flow Sensor with Venturi

PS-2225



The General Flow Sensor determines fluid velocity in air or water by measuring the difference in pressure between the two input tubes. Either the Venturi Tube or the Pitot Tube ME-2221 (see page 47) must be connected to the General Flow Sensor.



## Venturi Tube

The Venturi Tube is made of clear PVC so the water can be seen flowing through it. It has a constriction and two pressure ports with tubing attached. The Venturi Tube is connected to the General Flow Sensor by the matching couplers. The General Flow Sensor measures the difference in fluid pressure between the two different cross-sectional areas and the software does a calculation to convert this pressure difference into a velocity or volumetric flow rate. The Venturi Tube slip joints are designed to be glued into any 3/4" PVC pipe network.

## Pressure Taps

ME-2224



ME-2224 Includes six pressure taps and tubing.

The transparent Pressure Taps can be glued into a 3/4" PVC pipe network at any place, using a slip joint. Each Pressure Tap has a quick-connect for a Dual Pressure Sensor (PS-2181). Since the quick-connect closes when disconnected, it is possible to move the pressure sensor around the network to determine the pressures at different positions, rather than having a separate pressure sensor for each position.

## Wireless Interface



The SPARKlink Air (PS-2011) is a Bluetooth interface that allows the computer to be away from water spills. See page 9 for more information.

## Dual Pressure

PS-2181



### ▶ Measure pressure at two pipe pressure taps at once

The Dual Pressure sensor is capable of reading two absolute pressures, one gauge pressure, or one differential pressure.

### Specifications

**Absolute Pressure:** 0 to 200 kPa, 0.01 kPa resolution at 10 Hz and 1 kPa repeatability (displays pressure in kPa, N/m<sup>2</sup>, and psi)

**Differential Pressure:** ±100 kPa, 0.01 kPa resolution at 10 Hz and 1 kPa repeatability (displays pressure in kPa, N/m<sup>2</sup>, and psi)

**Maximum Sample Rate:** 1000 Hz

## Density Circulation Model

ME-6816

- ▶ Model density driven circulation based on temperature, dissolved substances, or different liquids
- ▶ Demonstrate the driving forces of vertical ocean currents
- ▶ Measure temperature inversions based on density difference



The PASCO Density Circulation Model allows students to model, measure and understand the complex density driven circulation associated with heat transfer through convection. Students can recreate vertical ocean currents driven by water bodies with density differences. They can extend this learning by using sensors to collect data and create graphs showing the thermocline, halocline and pycnocline using a Salinity Sensor PS-2195 (page 68).

Data showing temperature versus depth. Rapid temperature change occurs in the region where the two water bodies mix.

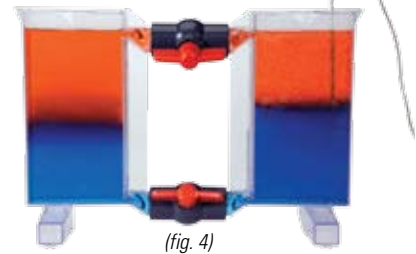
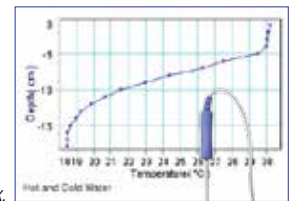

(fig. 4)

With the valves closed (fig. 1), two bodies of liquid can be created that differ in temperature, dissolved materials, or other properties. When the valves are opened, a smooth flow of liquid occurs between the chambers (fig. 2 & fig. 3). Minimal mixing occurs and clearly defined layers of liquid based on density result (fig. 4).



(fig. 1)

(fig. 2)

(fig. 3)

### Order Information

General Flow Sensor with Venturi Tube .....	PS-2225	
Pressure Taps (Set of 6) .....	ME-2224	
Dual Pressure Sensor .....	PS-2181	p. 41
<b>Required:</b>		
PASPORT Interface .....		pp. 10-11
PASCO Capstone Software .....		pp. 18-20
PVC Pipe and Fittings (Supplied by user)		
Pumps (2) (Supplied by user)		
<b>Shown in Use with:</b>		
SPARKlink Air .....	PS-2011	p. 10
Optional Pitot Tube .....	ME-2221	p. 41

### Order Information

Density Circulation Model .....	ME-6816
<b>Shown in use with:</b>	
Stainless Steel Temperature Probe .....	p. 45

## Fluids

## Explore the Equations for Fluid Flow Using Sensors

## General Flow Sensor with Venturi Tube

PS-2225

- ▶ Measure fluid velocities and confirm the Continuity Equation
- ▶ Use Bernoulli's Equation to determine pressure difference
- ▶ Show faster moving fluids have lower pressures



The Venturi Tube has pressure taps at the narrow diameter and the larger diameter.

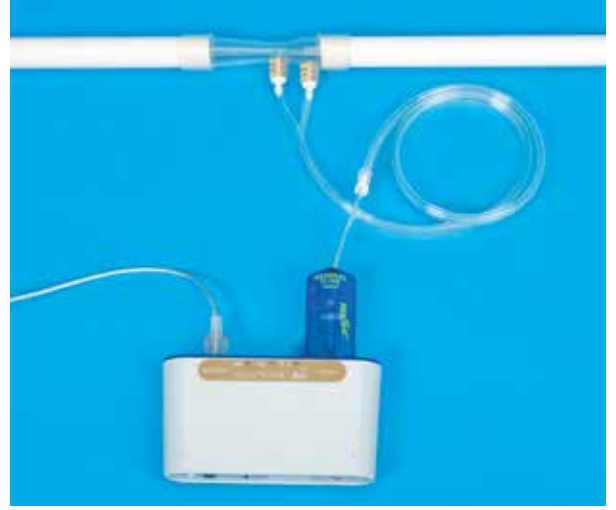

The General Flow Sensor connects to the Venturi Tube to measure the pressures.

Continuity Equation:  $A_1 v_1 = A_2 v_2$

Bernoulli's Equation:  $P_1 + \frac{1}{2}\rho v_1^2 = P_2 + \frac{1}{2}\rho v_2^2$  (at constant height)

In this apparatus, the Venturi Tube has pressure taps at the narrow diameter and the larger diameter. The General Flow Sensor connects to the Venturi Tube to measure the different pressures due to different fluid velocities. You supply the  $\frac{3}{4}$  inch PVC pipe and the water. It is suggested that you connect the pipe to a faucet with flexible tubing and, at the other end, let the water flow into a bucket resting on a Force Platform (PS-2141). As the water flows, the velocity can be determined by the changing weight of the bucket as measured by the Force Platform.

The recommended interface is the SPARKlink Air because two ports are required and it is convenient to have a wireless interface so your laptop can be away from the water. However, two AirLinks (PS-3200) or a 550 or 850 Universal Interface would do as well.

The experiments can be downloaded at [www.pasco.com/fluids](http://www.pasco.com/fluids).

## Order Information

General Flow Sensor with Venturi Tube .....	PS-2225
Force Platform .....	PS-2141
SPARKlink Air .....	PS-2011
PASCO Capstone Software .....	See pages 18-20

## Supplied by User:

PVC Pipe (3/4 inch), water, bucket

## Recommended (for velocity verification):

Pitot Tube .....	ME-2221
------------------	---------

## Density Set

ME-8569A

Use this versatile set of materials with the Overflow Can to investigate Archimedes' Principle of displacement, specific heats, and basic length/volume relationships.

Includes pieces that have the same shape, volume, density, and mass, so the variable of interest can readily be isolated. Each piece has a hole, so it can be suspended from a string.

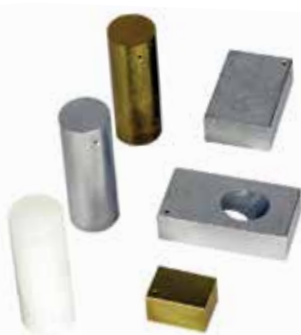

### Includes

- Three cylinders: aluminum, brass, plastic; 2.2 cm dia. x 6.4 cm long (plastic is less dense than water)
- Two blocks: aluminum: 1.9 x 3.2 x 4.1 cm and brass: 1.6 x 1.9 x 2.8 cm. The mass of each block equals that of the aluminum cylinder; irregular shape: aluminum; instruction manual

### Order Information

Density Set.....ME-8569A

## Discover Density Set

SE-9719A

This set of 22 separate pieces allows students to discover the relationship between density, volume, and dimensions. Two unique series of pieces hold one dimension constant while varying another.



### Includes

- Cylinders of same length and different diameters (4)
- Cylinders of same diameter and different lengths (4)
- Spheres with different diameters (4)
- Rectangular shapes of various sizes and materials (10)
- Instruction manual

### Order Information

Discover Density Set.....SE-9719A

## Mole Set

SE-7586

The Mole Set contains four element specimens: Copper, Iron, Zinc and Aluminum. Each sample contains approximately one mole,  $6.02 \times 10^{23}$  atoms of the element.

### Includes

- Mole samples: Zinc, Aluminum, Iron, Copper
- Teaching Suggestions

### Order Information

Mole Set.....SE-7586

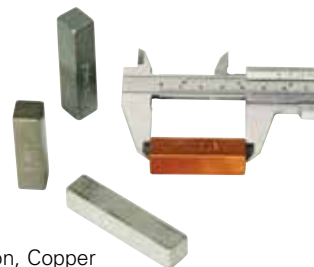

## Overflow Can

SE-8568

This aluminum Overflow Can provides direct volume measurements for the materials supplied in the Density Set, as well as displacement measurements for buoyancy experiments. It has a 76 mm diameter, a usable volume of 477 cm<sup>3</sup>, and an angled downspout. Requires a graduated cylinder or a gram balance to measure the displaced volume.

### Includes

- Can only

### Order Information

Overflow Can.....SE-8568



## Classroom Density Set

SE-7226

The Classroom Density Set includes 12 sets of materials to study the density concept. Each material set includes four pieces of various sizes in a plastic storage tube. This selection of materials allows twelve lab groups to perform a density experiment at the same time.

For each set, students measure the mass and volume of each piece and produce a mass vs. volume graph. Students will better understand density as a mathematical concept and realize that density is constant for a given material.

### Includes

- (Four different sizes of each material listed)
 

Maple	Polystyrene	PVC	CPVC
Polypropylene	Nylon	PETG	Teflon
HDPE	Acrylic	Acetal	Aluminum

### Order Information

Classroom Density Set.....SE-7226



## Glassware

Rugged borosilicate glassware for use in the physics lab.

### Order Information

100 ml Beaker (12 pack).....SE-7287  
 1000 ml Beaker (6 pack).....SE-7288  
 50 ml Graduated Cylinder (12 pack).....SE-7289



## Lab Supplies

### Large Rod Base

ME-8735

- ▶ Stable 4 kg casting
- ▶ Leveling feet
- ▶ Supports two rods

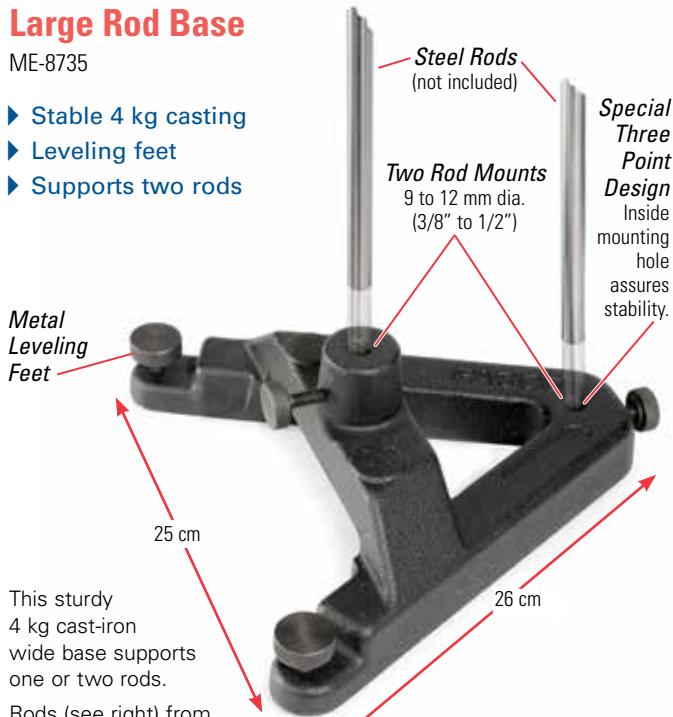

This sturdy 4 kg cast-iron wide base supports one or two rods.

Rods (see right) from 9.5 to 13 mm (3/8 to 1/2 inches) can be supported. Two adjustable feet provide the necessary leveling capabilities.

#### Order Information

Large Rod Base.....ME-8735

### Metal Knobs and Feet (4 pack)

ME-8954

These replacement knobs and feet for the ME-8735 Large Rod base are made of solid steel with knurled knobs and 5/16" -24 thread



#### Order Information

Metal Knobs and Feet.....ME-8954

### Small "A" Base

ME-8976

This 1.7 kg cast iron base is smaller than the Large Rod Base (above) and does not have leveling feet. This base can be used with both threaded and non-threaded rods. Non-threaded rods from 9.5 to 13 mm (3/8 to 1/2 inches) diameter can be supported. Threaded rods must be 12.7 mm (1/2 inch) in diameter with 1/2"-13 thread, such as the 60 cm rod shown at right.



#### Order Information

Small "A" Base.....ME-8976

### Stainless Steel Rods

These 12.7 mm (1/2 in.) diameter stainless steel rods do not mar like aluminum rods. They are non-magnetic, very rigid, and durable.

Three different lengths are available in the non-threaded version.

The 60 cm long rod and 25 cm long rod are threaded (1/2"-13) and fit the Small "A" Base, the Small Round Base, and the Universal Table Clamp ME-9376B.

(Bases shown, not included)

120 cm Long  
ME-8741

90 cm Long  
ME-8738

60 cm Long  
Threaded Rod  
ME-8977

Shown with  
Small "A" Base

45 cm Long  
ME-8736

Shown with  
Large Rod Base

25 cm Long  
Threaded Rod  
ME-8988

Shown with  
Small Round Base



#### Order Information

Stainless Steel Rods 12.7 mm (1/2 in.) in diameter:

45 cm Long (non-threaded).....	ME-8736
90 cm Long (non-threaded).....	ME-8738
120 cm Long (non-threaded).....	ME-8741
25 cm Long (threaded).....	ME-8988
60 cm Long (threaded).....	ME-8977

## PASCO's Flex Rod

ME-8978A

► Flexible rod for holding objects in any orientation

The Flex Rod provides the freedom to place equipment where it's needed. Simply connect the object to the end of the 46 cm long flexible tubing and move it to the desired location. The tubing has enough rigidity to hold many common items in any orientation. In addition, two convenient clamps are included.



The Flex Rod with rod clamp attachment fits sensor handles.

Flex Rod holds photogate for Acceleration Due to Gravity experiment using a picket fence (shown with Table Clamp, not included).



Laser pointer

The Flex Rod holds a green laser pointer. Shown with Small "A" Base (not included).



### Includes

- Flex Rod attached to rigid section
- Rod Clamp attachments (2)
- 3-finger clamp attachment (Base support not included.)

### Order Information

Flex Rod .....ME-8978A

Suggested Base Supports:

Small "A" Base .....ME-8976 p. 176

Aluminum Clamp .....ME-8995 p. 179

## Base and Support Rod

Large  
ME-9355

Round  
ME-8270



### 1. Large Base and Support Rod:

With built-in leveling screws and a threaded aluminum rod that is 12.7 mm (1/2 in.) in diameter and 45 cm long.

### 2. Round Base with Rod: The threaded steel rod is 12.7 mm (1/2 in.) in diameter and 25 cm long.

### Order Information

Large Base and Support Rod .....ME-9355

Round Base with Rod.....ME-8270

## How to choose the best mounting rod for you



Both of these rods are useful for mounting sensors, particularly photogates. Also, they work well for pulleys.

The SA-9242 stainless steel rod is the same length as the ME-9483 plastic rod. However, the steel rod has a smaller diameter that may not work with all clamps that require a standard 12.7 mm (1/2 in) diameter. The ME-9483 plastic rod is made of a hard plastic that clamp screws do not dent and it has a threaded brass stud. The lighter weight of the plastic rod will not damage pulleys when thrown into a bin.

## Mounting Rods (10 pack)

ME-9483

These rigid plastic pulley handles (14 cm long, 12.7 mm diameter) have a 1/4"-20 metal stud that screws into a Super Pulley.



### Order Information

Mounting Rods (10 pack)..... ME-9483

## Pulley Mounting Rod

SA-9242

This 14 cm long stainless steel mounting rod is 9.5 mm (3/8 in.) in diameter and fits most standard laboratory clamps, including the PASCO Universal Clamp. It has a standard 1/4"-20 thread.



### Order Information

Pulley Mounting Rod ..... SA-9242

**Right Angle Clamp**

SE-9444



**Buret/Utility Clamp**

SE-9446



**Three-finger Clamp**

SE-9445



**Right Angle Clamp (SE-9444)**

This standard right angle clamp fits rods up to 18 mm (11/16 inch) in diameter.

**Buret/Utility Clamp (SE-9446)**

The V-shaped, plastic-coated jaws of this Buret Clamp open from 5 to 35 mm, rotate 360°, and lock in position at any angle. Fits rods up to 16 mm (5/8 inch) in diameter.

**Three-finger Clamp (SE-9445)**

Clamp tubes, rods, and irregularly shaped objects. The jaws extend 19 mm, open to 57 mm, rotate 360°, and lock securely at any angle. Fits rods up to 19 mm (3/4 inch) in diameter.

**Order Information**

Right Angle Clamp .....	SE-9444
Buret/Utility Clamp.....	SE-9446
Three-finger Clamp.....	SE-9445

**Pendulum Clamp**

ME-9506



Hang up to three springs or pendula. Suspension points are 54 mm apart. Fits rods up to 16 mm (5/8 inch) in diameter.

See page 157 for more information.



Easily adjust length of pendulum.

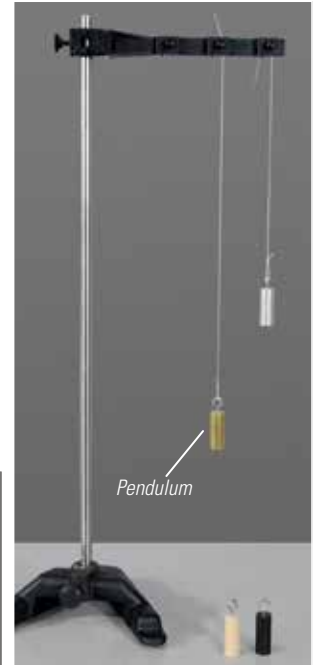

Pendulum

**Order Information**

Pendulum Clamp .....	ME-9506	
<i>Shown in use with:</i>		
Photogate Pendulum Set.....	ME-8752	p. 157
Small "A" Base .....	ME-8976	p. 176
Stainless Steel Rod (45 cm.) .....	ME-8736	p. 176

**Multi Clamp**

ME-9507

Holds two rods either parallel or at right angles. Fits rods up to 12.7 mm (1/2 inch) in diameter.

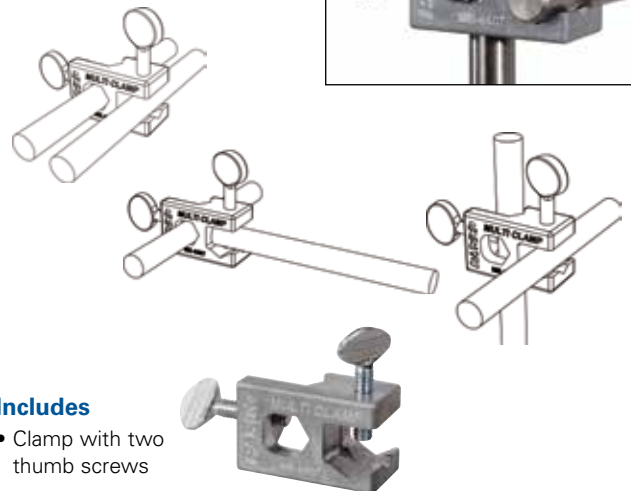

**Includes**

- Clamp with two thumb screws

**Order Information**

Multi Clamp .....	ME-9507
-------------------	---------

## Table Rod Clamps

These clamps hold up to 12.7 mm (1/2 inch) diameter rods that can be mounted either horizontally or vertically.



### Order Information

Large Table Clamp .....	ME-9472
<i>10 cm grip range</i>	
Aluminum Table Clamp .....	ME-8995
<i>6 1/2 cm grip range</i>	
Universal Table Clamp .....	ME-9376B
<i>6.0 cm grip range</i>	

## "C" Clamps

SE-7285 Large

This rugged clamp is perfect for attaching a variety of objects to a table. Available in 10 cm (4-inch) size.



*Appearance may vary.*

### Order Information

Large "C" Clamp (6 pack).....	SE-7285
-------------------------------	---------

## Laboratory Jacks

Raise, support, and align equipment with these lab jacks. They're rugged, stable, and ensure precise height adjustment. Two sizes are available.



### Order Information

Laboratory Jack	Model	Platform (cm)	Height (cm)	Load (kg)
Medium .....	SE-9373	15x15.....	7 - 25	25
Large.....	SE-9372	20x20.....	7 - 25	25

## Universal Table Clamp

ME-9376B

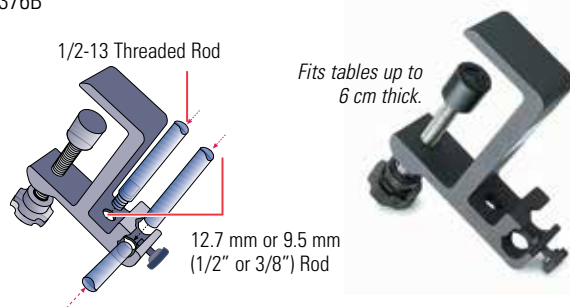

Attach this Universal Table Clamp to tables or shelves up to 6.0 cm (2 3/8 inch) thick. Can also be mounted on a ring stand. Mount rods in the clamp either vertically or horizontally. The rods are held securely by stable three-point contacts. Use standard unthreaded lab rods — 9.5 mm (3/8 inch) to 12.7 mm (1/2 inch) — vertically or horizontally. Use 1/2-13 threaded lab rod vertically.

### Order Information

Universal Table Clamp .....	ME-9376B
-----------------------------	----------

## Double Rod Clamp (3 pack)

ME-9873

Holds any two rods up to 12.7 mm (1/2 inch) in diameter, either parallel or perpendicular to one another.



### Order Information

Double Rod Clamp (3 pack).....	ME-9873
--------------------------------	---------

## Swivel Clamp (2 pack)

ME-8743

Clamp two rods at any angle or clamp the two rods parallel to each other. Accepts 12.7 mm (1/2 inch) rods.

### Includes

- Two Clamps



### Order Information

Swivel Clamp (2 pack).....	ME-8743
----------------------------	---------

## Adjustable Angle Clamp

ME-8744

This unique clamp fits any rod up to 12.7 mm (1/2 inch) diameter and can lock the rod in place at any angle.

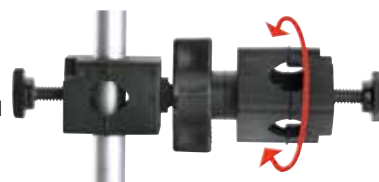

### Order Information

Adjustable Angle Clamp .....	ME-8744
------------------------------	---------

## Pulleys

### Super Pulley

ME-9450A

- ▶ 20 N max load
- ▶ Nearly frictionless
- ▶ Durable

The PASCO Super Pulley is the standard in physics labs. Its low-friction design produces excellent results. The precision spacing of the 10 spokes makes it ideal for photogate monitoring with PASCO's computer interfaces and photogate systems.



#### Features

- ▶ Low Friction
- ▶ Lightweight
- ▶ Precision Dimensions

#### Order Information

Super Pulley ..... ME-9450A

### Pulley Mounting Rod

SA-9242

This 14 cm long stainless steel mounting rod is 9.5 mm (3/8 in.) in diameter and fits most standard laboratory clamps, including the PASCO Universal Clamp.



#### Order Information

Pulley Mounting Rod  
(rod only) ..... SA-9242

### Smart Gate Pulley System

PS-3702

The Super Pulley attaches directly to the Smart Gate, providing a simple, low-friction system to measure position, velocity and acceleration. Additionally, with the pulley removed, the photogate can be used to perform standard photogate experiments.



#### Includes

- Smart Gate (1) PS-2180
- Super Pulley (1) ME-9450A
- Super Pulley Rod (1) ME-8736

#### Order Information

Smart Gate Pulley System.....PS-3702

### Super Pulley with Mounting Rod

ME-9499

This Super Pulley mounted on a rigid plastic mounting rod (12.7 mm diameter, 14 cm long) fits most standard laboratory clamps.



#### Order Information

Pulley with  
Mounting Rod ..... ME-9499

### Super Pulley with Clamp

ME-9448B



Upgrade your force table and inclined plane experiments. The Super Pulley with its integral clamp makes setup and alignment easy. The pulley height is fully adjustable, so you can skim the top of a force table for parallax-free readings. Yet you can keep the force parallel to the track on an inclined plane, as shown in the photo below. Fits tables up to 2.0 cm (13/16 in.) thick.



#### Order Information

Super Pulley  
with Clamp ..... ME-9448B

### Mounting Rods (10 pack)

ME-9483

These rigid plastic pulley handles (14 cm long, 1.27 mm diameter) screw into a Super Pulley.



#### Order Information

Mounting Rods  
(10 pack) ..... ME-9483

### Photogate/ Pulley System

ME-6838A

The Super Pulley attaches directly to the Photogate Head, providing a simple, low-friction system to measure position, velocity and acceleration. Additionally, with the pulley removed, the photogate can be used to perform standard photogate experiments. See page 39.



#### Order Information

Photogate/Pulley  
System ..... ME-6838A

### Atwood's Machine

SA-9241



Two Super Pulleys mounted on a 6.4 cm long rod produce a classic, low-friction introduction to Newton's Second Law. The instruction sheet fully describes both the experiment and the theory.



#### Includes

- Two Pulleys
- Connecting Rod

#### Order Information

Atwood's  
Machine..... SA-9241

## Metric Spring Scales

(Five different ranges)

These high-quality metric spring scales are precise, durable, and calibrated in Newtons. Five different scales are available. Students can measure forces from a fraction of a Newton to 20 Newtons with excellent accuracy.

### Features

- ▶ **Accurate:** The precision springs provide excellent linearity, and the 10 cm long scales are sharp and clear for superior resolution.
- ▶ **Sealed Spring:** Can't get tangled, over-stretched, or lost.
- ▶ **Zero Adjust:** Turn the knob to zero the balance.
- ▶ **Scales on Inside:** They won't wear off.
- ▶ **Five Color-coded Ranges:** Measure almost any force from 0.1 N to 20 N.

*Graduations are easy to read, and the resolution is 2% of full scale.*



*PASCO Spring Scales: Five metric spring scales provide accurate measurements over a wide range of forces.*

### Order Information

#### Metric Spring Scales

Model	Range	Resolution	Color
ME-9509	1.0 N	0.02 N	Red
ME-9510	2.0 N	0.04 N	Lt. Green
ME-9511	5.0 N	0.1 N	Brown
ME-9512	10 N	0.2 N	Dk. Green
ME-9513	20 N	0.4 N	Orange

## Tension Protractor

ME-6855

- ▶ Measure tension and angle with one device
- ▶ Large scale for viewing demonstrations
- ▶ Zero-adjust for torsion spring scale
- ▶ Built-in rod clamp

See page 139 for more information.

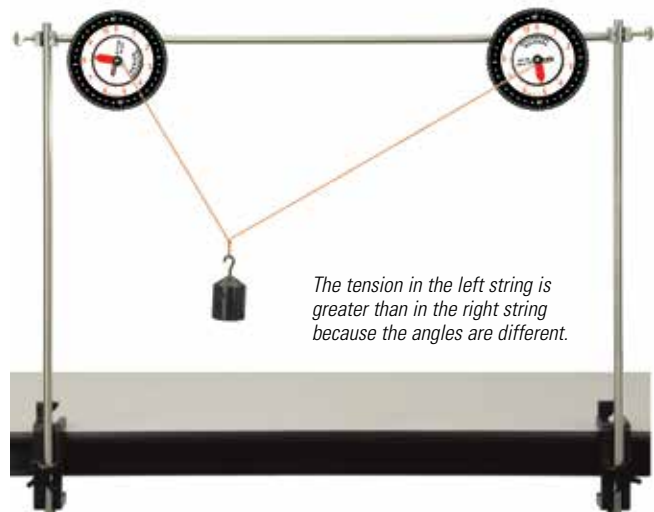

*The tension in the left string is greater than in the right string because the angles are different.*

*Outside degree scale can be rotated to set the zero.*

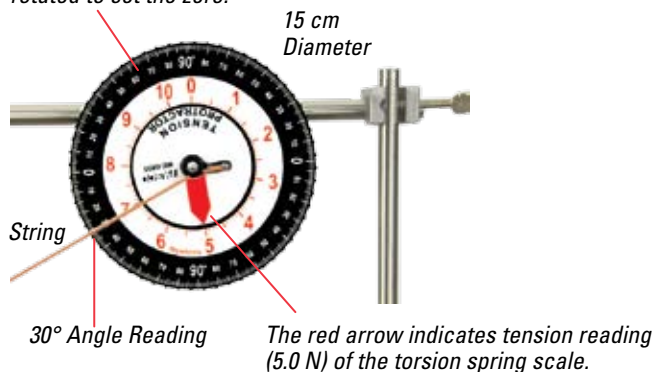

15 cm Diameter

String

30° Angle Reading

*The red arrow indicates tension reading (5.0 N) of the torsion spring scale.*

### Includes

- One Tension Protractor



### Order Information

Tension Protractor .....	ME-6855	
<i>Recommended:</i>		
Large Table Clamp .....	ME-9472	p. 179
90 cm Long Rod .....	ME-8738	p. 176
Multi Clamp .....	ME-9507	p. 178
Hooked Mass Set .....	SE-8759	p. 187

## Lab Supplies

### Metric Measuring Tape

SE-8712A



This 30-meter woven fiberglass measuring tape reads metric on one side and English on the other.

#### Order Information

Metric Measuring Tape ..... SE-8712A

### Digital Calipers

SE-8710



This metric/English (15 cm/6 in.) digital caliper measures to 0.01 mm (0.0005 in.). It has auto power-off and includes a sturdy plastic storage case.

#### Order Information

Digital Calipers ..... SE-8710

### Stainless Steel Calipers

SF-8711



These metric/English (18 cm/6 in.) calipers have an expanded Vernier scale of 20 divisions (instead of the usual 10), so it's easier to read and more accurate. The sliding mechanism is smooth and durable. A case is included for added protection.

#### Order Information

Stainless Steel Calipers ..... SF-8711

### High Quality Meter Sticks (6 pack)

SE-8827



Hardwood meter stick with metric graduations. Scale reads left to right on one side, right to left on the other.



*Cross-section dimensions:  
7 mm x 28 mm.*

#### Order Information

Meter Stick (6 pack) ..... SE-8827

### Four-Scale Meter Stick

SE-8695



The Four-Scale Meter Stick is constructed of plastic square channel. One side has millimeter markings, one has centimeter markings, one has decimeter markings, and the last side has only a one-meter mark.

#### Order Information

Four-Scale Meter Stick ..... SE-8695

### Micrometer

SE-7337



This low-cost micrometer provides measurements from 0 to 25 mm with 0.1 mm resolution. The wooden box is form-fitted to protect the micrometer during storage.

#### Order Information

Micrometer ..... SE-7337

## Freefall Balls Accessory

ME-9890

This set of balls is used with the Discover Freefall system shown on page 124. The special stickers are used to attach the metal washers to the plastic balls, allowing them to be suspended from a magnet.

**WARNING**  
**CHOKING HAZARD**  
Contains small balls. Not for children under 3 years.



### Includes

- Small Nylon Ball (2.5 cm)
- Large Plastic Ball (10 cm)
- Golf Ball (4.4 cm)
- Hollow Golf Ball (4.2 cm)
- Steel Ball (2.5 cm)
- Steel Ball (1.6 cm)
- Release Washers (10)
- Release Stickers (50)



### Order Information

Freefall Balls  
Accessory .....ME-9890

## Bounce/No Bounce Ball Set (3 sets)

SE-7571

**WARNING**  
**CHOKING HAZARD**  
Contains small balls. Not for children under 3 years.



These two black balls look and feel identical, but drop them side by side and students will notice a big difference in their elasticity.

One bounces close to the original drop height, while the other doesn't bounce at all. Includes three sets of the Bounce/No Bounce Balls. Each ball has a diameter of 2.5 cm.



### Order Information

Bounce/No Bounce  
Ball Set (3 sets) .....SE-7571

## Small Steel Balls

ME-9872

**WARNING**  
**CHOKING HAZARD**  
Contains small balls. Not for children under 3 years.



These 1.6 cm diameter steel balls are used with the Mini Launcher (ME-6825).

### Order Information

Small Steel Balls  
(10 pack) ..... ME-9872

## Plastic Balls

ME-6822

**WARNING**  
**CHOKING HAZARD**  
Contains small balls. Not for children under 3 years.

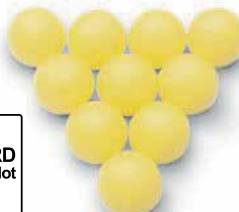

Extra brightly colored balls are available for the Projectile Launcher. Diameter is 2.5 cm (1 in.).

### Order Information

Plastic Balls  
(10 pack) ..... ME-6822

## Steel Balls

ME-9864

**WARNING**  
**CHOKING HAZARD**  
Contains small balls. Not for children under 3 years.



Four pack of 2.5 cm diameter balls for use with PASCO Short- or Long-Range Projectile Launchers (ME-6800 or ME-6801).

### Order Information

Steel Balls  
(4 pack) .....ME-9864

## Spherical Mass Set

ME-8968

This set includes four balls with a diameter of 2.5 cm each, but featuring various masses, including a hollow steel ball.

**WARNING**  
**CHOKING HAZARD**  
Contains small balls. Not for children under 3 years.



### Includes

- Solid Yellow Nylon Ball (10 grams)
- Solid Steel Ball (66 grams)
- Hollow Steel Ball (21 grams)
- Solid Aluminum Ball (24 grams)

### Typical Applications

- ▶ Race the hollow steel ball and solid aluminum ball down an incline. They have about the same mass, but the solid aluminum ball has a much larger acceleration down the ramp.
- ▶ Fire the yellow plastic, solid steel, and hollow steel balls from a PASCO Short- or Long-Range Projectile Launcher.

### Order Information

Spherical  
Mass Set .....ME-8968

## Lab Supplies

### Braided Physics String

SE-8050

#### ▶ 30-lb. Test

This braided Dacron® string is tough, resists stretching, and won't unravel. Withstands up to 133 Newtons of force (equivalent to 13.6 kg). Each roll provides 320 meters of string.



#### Order Information

Braided Physics String .....SE-8050

### Elastic Wave Cord

SE-9409

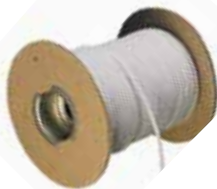

Unlike a Slinky®, the tension can be varied. In addition to the Slinky, this Wave Cord is great for wave demonstrations. The cord is 3 mm in diameter. Each roll provides 90 meters of cord.

#### Order Information

Elastic Wave Cord .....SE-9409

### Yellow Cord

ME-9876



Two rolls of highly visible braided yellow cord. Total length of 140 meters.

#### Order Information

Yellow Cord (2 pack) .....ME-9876

### Rubber Cord (30 meters)

ME-8986



For Elastic Bumper (ME-8998)  
Also fits Air Track Bumpers (page 121)

#### Order Information

Rubber Cord (Spool of 30 m) ..... ME-8986

### Glow String (2 pack)

SE-8690



*Color may vary.*



This stretchy "string" glows in the dark after being exposed to light. Use it to demonstrate wave motion, including resonance and standing wave patterns. Two rolls are included, totaling over 15 meters of string.

#### Order Information

Glow String (2 pack) .....SE-8690

### Black Thread

ME-9875



Includes three spools of black Nylon thread.

#### Order Information

Black Thread (3 pack) .....ME-9875

### Plumb Bobs (10 pack)

SE-8728



These finished steel plumb bobs are precision-machined to a fine point. Just slide a string through the hole in the top and tie a knot. The plumb bob hangs precisely centered.

#### Order Information

Plumb Bobs (10 pack) .....SE-8728

### No-Bounce Pad

SE-7347



Stop falling objects from bouncing with PASCO's No-Bounce Pad. The 30 cm x 30 cm x 2.5 cm dimensions of the pad provide an ample target for gravity demonstrations. Prevents heavy objects from damaging the floor and prevents falling objects from being damaged on impact.

#### Order Information

No-Bounce Pad .....SE-7347

### Carbon Paper (100 pack)

SE-8693

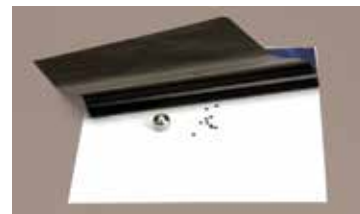

Carbon paper is ideal for marking the position of an object as it strikes the floor or other surface.

#### Order Information

Carbon Paper (100 sheets) .....SE-8693

### Spirit Levels (10 pack)

SE-8729



These 23 cm long Spirit Levels have three vials with striped graduations to indicate vertical, horizontal, and 45° alignment. The frame is a durable plastic with tough acrylic vials. A magnetic tape allows hands-free leveling.

#### Order Information

Spirit Levels (10 pack) ..... SE-8729

## Storage Bins

SE-7560

These stackable plastic bins with lids are useful for storing sensors. 14" long, 9.5" wide, 6.9" high.



### Order Information

Storage Bins (set of 5) ..... SE-7560

## 3.8 Liter Plastic Container Set

ME-7559

These containers are great for experiments needing ice-water baths. See the Heat Engine Experiment on page 346 for an example.



14 cm x 14 cm x  
19.5 cm tall

### Order Information

3.8 Liter Plastic Container Set  
(set of 2) ..... ME-7559

## Water Reservoir

ME-8594

This calibrated 1000 ml cylinder is useful for experiments (as shown on page 227), requiring either a specific amount of water, a constant flow of water, or water at a constant pressure. The cylinder has three hose connections, one for connection to a source of water, one for overflow, and an outlet near the bottom. The unit comes with six meters of tubing and two restriction clips.



### Order Information

Water Reservoir ..... ME-8594

## Glassware

Rugged borosilicate glassware for use in the physics lab, particularly useful for buoying labs (shown on page 330).



### Order Information

100 ml Beaker (12 pack) ..... SE-7287  
1000 ml Beaker (6 pack) ..... SE-7288  
50 ml Graduated Cylinder (12 pack) ..... SE-7289

## Discover Pi Set (10 pack)

ME-6819A



The Discover Pi Set allows students to derive the meaning of  $\pi$  directly from their measurements. This activity transforms  $\pi$  from a constant with unknown origin to a fundamental characteristic of all circular objects.

### Includes

- Pi Circles (4): 5.2, 6.4, 8.9, 10.0 cm diameter
- Transparent Measuring Tape

### Order Information

Discover Pi Set (10 pack) ..... ME-6819A

## Balances

## Ohaus Electronic Balances

SE-8823A (220 g)  
SE-8756B (420 g)  
SE-8757B (2200 g)  
SE-8758B (8200 g)



The Ohaus Scout SKX digital electronic balances combine range, resolution, and low cost, making them ideal for the student physics lab.

Simple two-button operation and visual menu prompts allow students to begin weighing with minimal instruction. The large, crisp display is easily viewed from any angle, so teachers can quickly check student results. A sealed front panel, molded spill ring, and removable stainless steel platforms provide protection from spills and make these balances easy to keep clean.

## Specifications

Catalog #	SE-8823A	SE-8757B	SE-8758B	SE-8756B
Capacity:	0-220 g	0-2200 g	0-8200 g	0-420 g
Resolution:	0.01 g	0.1 g	1.0 g	0.01 g
Pan Size:	12 cm dia	16.5 x 4.2 cm	16.5 x 14.2 cm	12 c

**Make these balances work with PASCO Capstone and SPARKvue on your computer via Bluetooth or USB with:**

Ohaus Bluetooth  
Device Adapter ..... SE-8822  
Ohaus USB  
Device Adapter ..... SE-8821

## Order Information

Ohaus Scout SKX Balances  
220 g ..... SE-8823A  
420 g ..... SE-8756B  
2200 g ..... SE-8757B  
8200 g ..... SE-8758B

## Ohaus Triple-Beam Balance

SE-8723 (without tare)  
SE-8707 (with tare)



## Ohaus Cent-o-Gram Balance

SE-8725



Ohaus mechanical balances have been the standard weighing instruments in student laboratories for decades. They're accurate, easy to use, durable, and inexpensive.

## Features

- ▶ Precision-Ground Steel Knives: for exact measurements and a long balance life.
- ▶ Stainless Steel Weighing Pan: easy to clean, lasts indefinitely.
- ▶ Magnetic Damping: for quick, true measurements.
- ▶ Simple Zero-Adjustment: just zero the masses, then rotate the knob.
- ▶ Capacities: see table below.

## Specifications

Product #	SE-8723	SE-8707	SE-8725
Ohaus #	750-S0	760-00	311-00
Type:	Triple-Beam	Triple-Beam	Cent-o-Gram
Capacity:	610 g	610 g	311 g
w/add'l. mass set:	2610 g	2610 g	N/A
Readability:	0.1 g	0.1 g	0.01 g
Tare:	None	225 g	None

## Order Information

Ohaus Triple-Beam Balance  
(without tare) ..... SE-8723  
(with tare) ..... SE-8707

Ohaus Cent-o-Gram  
Balance ..... SE-8725

**Recommended:**  
Ohaus Additional  
Mass Set ..... SE-8708

## Ohaus Additional Mass Set

SE-8708

(for Triple-Beam Balances)



These additional masses can increase the range of the Ohaus Triple-Beam Balance (SE-8723 and SE-8707) by an additional 2 kg. Included are a 0.5 kg and two 1 kg masses.

## Order Information

Ohaus Additional  
Mass Set ..... SE-8708

## Slotted Mass

SE-8726A Set (10 g resolution)  
SE-8704A Set (1 g resolution)  
SE-8703A Hanger (50 g)

*This 50 gram mass hanger is the standard hanger for the slotted masses shown.*



These slotted masses provide medium to heavy mass (up to 1.110 kg) with 1 g or 10 g resolution.

## The SE-8726A Set includes

- Masses: 1 x 500 g 2 x 200 g 1 x 100 g  
1 x 50 g 2 x 20 g 1 x 10 g

## The SE-8704A Set includes

- The above masses plus a 5 g, 1 g, and two 2 g. Mass hangers available separately.

## Order Information

10 g Slotted Mass Set ..... SE-8726A  
1 g Slotted Mass Set ..... SE-8704A  
Slotted Mass Hanger ..... SE-8703A

## Mass and Hanger Set

ME-8979 (1/2 g resolution)

PASCO's Mass and Hanger Set features precision 5 g mass hangers with steel posts, and "holed" masses that will not fall off the hanger. All the masses have their values marked, and each hanger can hold up to 250 g.



### Includes

- Four mass hangers (5 g each)  $\pm$  2%
- Brass masses:  $\pm$  1%
  - 3 x 100 g    3 x 50 g    6 x 20 g
- Aluminum masses:  $\pm$  1%
  - 3 x 10 g    3 x 5 g
- Plastic masses:  $\pm$  2%
  - 3 x 2 g    3 x 1 g    3 x 0.5 g
- Molded storage case

### Order Information

Mass and Hanger Set ..... ME-8979

#### Recommended:

Mass and Hanger Spares Kit.... ME-8980

(Contains four mass hangers and 10 each of 2 g, 1 g, and 0.5 g plastic masses)

#### Replacement Mass Sets for ME-8979:

5-gram Mass Set (set of 6)..... ME-8981

10-gram Mass Set (set of 6)..... ME-8982

20-gram Mass Set (set of 6)..... ME-8983

50-gram Mass Set (set of 6)..... ME-8984

100-gram Mass Set (set of 6).... ME-8985

## Large Slotted Mass Set

ME-7566 (5 kg Set)

### Includes

- One 0.5 kg mass hanger
- Nine 0.5 kg slotted masses.
- Diameter of masses: 8 cm.
- Height of hanger: 36 cm.



### Order Information

Large Slotted Mass Set (5 kg Set)..... ME-7566

## Short Slotted Mass Set

ME-7589 (2 kg Set)

### Includes

- One 0.5 kg mass hanger
- Three 0.5 kg slotted masses.
- Diameter of masses: 8 cm.
- Height of hanger: 15 cm.



### Order Information

Short Slotted Mass Set (2 kg Set)..... ME-7589  
Short Mass Hanger ..... ME-7590

## Hooked Mass Set

SE-8759



This rugged Hooked Mass Set is made from cast iron and coated with enamel.

### Includes

- Masses: 1 x 1000 g    1 x 500 g    2 x 200 g  
                          1 x 100 g    1 x 50 g    2 x 20 g  
                          1 x 10 g
- Molded mass holder

### Order Information

Hooked Mass Set..... SE-8759

## 1 kg Mass and Hanger Set

ME-9337 (1 kg set)

Set features a 200 g cast aluminum mass hanger with a steel post, and four "holed" 200 g brass masses that will not fall off the hanger. Multiple mass hangers can be used by hooking the top of one into the bottom of another.



The flat bottom on the mass hanger makes it perfect for use with a Motion Sensor when performing Hooke's Law and spring oscillation experiments.



Can be used in conjunction with the entire set of smaller brass and plastic masses in the ME-8978 Mass and Hanger Set.



### Includes

- Mass hanger (ME-9350)  
Height of hanger: 16 cm
- Set of four masses (ME-9351)  
Diameter of masses: 5 cm
- Steel pin  
8 cm height, 3.6 mm diameter

### Order Information

1 kg Mass and Hanger Set..... ME-9337

Mass Hanger (200g) ..... ME-9350  
200g Masses

(set of four)..... ME-9351

#### Shown in use with:

Base and Rods ..... p. 176

Equal Length Spring Set..... ME-8970

Pendulum Clamp..... ME-9506

Motion Sensor..... PS-2103A

# Stopwatches

## PASCO Stopwatch

ME-1234

- ▶ No alarm or clock
- ▶ Memory for stored event times
- ▶ Uses one AA battery
- ▶ Durable buttons

Are you tired of annoying stop-watch alarms going off all day? Are your students stuck in the clock mode and can't get their stopwatch back into the timing mode? Does your stopwatch stop working after changing that little watch battery? The PASCO Stopwatch solves all these problems!

This stopwatch was designed specifically for science timing. The modes of operation are intuitive and complete instructions are included. The buttons are built to last and it uses a single long-lasting AA battery, which is less expensive than a watch battery (and easier to install).



Two Display Modes:  
MM:SS.SS (00:25.18) or  
Decimal Seconds (25.18s)

The EVENT/RECALL button allows you to view the last time, in case students forget to write down their data. The EVENT/RECALL button is also used to store and recall up to nine event times. For example, record a series of events, such as times at which sandbags were dropped along the gym floor.



The PASCO Stopwatch fits comfortably in your hand.



It also sits on the table at a convenient viewing angle.

### Order Information

PASCO Stopwatch ..... ME-1234

### Specifications

**LED Display:** Visible indoors and outdoors

**Two Display Modes:** MM:SS.SS (01:25.34) or Decimal Sec (85.34 s)

**Precision:** 0.01 sec up to 59:59.99 (MM:SS.SS) or 3599.99 s  
Then 1 sec to 99:59:59 (HH:MM:SS) or 359999 s

**Max Number of Event Times:** Nine

**Auto-off:** After one hour idle  
Can Be Used with a Lanyard (not included)

**Includes:** AA battery and instruction sheet

## PASCO Stopwatch (10 pack)

ME-1235

- ▶ Includes fitted foam storage box



### Order Information

PASCO Stopwatch (10 pack)..... ME-1235

## Student Timer

SE-8768

### Features

(Appearance may vary)

- ▶ Inexpensive
- ▶ 0.01 Second Resolution
- ▶ Easy Operation: Start/Stop, Reset and Lap



### Order Information

Student Timer ..... SE-8768

**PASCO's modular LED Strobe makes it easy for students to visualize motion.**

## Strobe

ME-6978

- ▶ 1 Hz to 500 Hz
- ▶ Variable intensity
- ▶ Low cost

Unique modular design makes it easy to light any geometry. The Strobe includes the Strobe Control Box and one Strobe Module. Additional Strobe Modules can be purchased separately (see below) for up to a total of four lamp modules per controller. And multiple control boxes can be connected together using the External Trigger. The Strobe Modules have a tilting lamp head on a sturdy base that sits on the table or fastens to a rod stand.



### Features

- ▶ Display frequency in Hz or rpm
- ▶ Adjustable light intensity
- ▶ External trigger daisy-chains multiple controllers together
- ▶ Trigger strobe using external input such as the photogate ME-9498A.

### Specifications

**Frequency Range:** 1 Hz to 500 Hz  
**Resolution:** 0.1 Hz  
**Accuracy:** 0.1%  
**Lamp Life:** 50,000 hours  
**Brightness:** 230 lumens (peak) per module

### Order Information

Strobe.....	ME-6978
(Includes Control Box and one Strobe Module)	
Additional Strobe Modules .....	ME-6982
<i>Shown in use with:</i>	
String Vibrator .....	WA-9857A p. 244
Sine Wave Generator .....	WA-9867 p. 245

# Thermal Expansion

## Thermal Expansion Apparatus

TD-8856

- ▶ Use with Multimeter or Temperature Sensor
- ▶ Brass, copper, and aluminum tubes included

With PASCO's Thermal Expansion Apparatus, students can accurately and easily investigate the expansion of metals with increasing temperature.



**Base**  
Provides storage for all three tubes.

**Steam Generator**  
(Sold separately)



**Built-in Digital Gauge**  
Simple and very accurate measurements with 0.01 mm resolution.



**Built-in 10 kΩ Thermistor**  
Together with a digital ohmmeter, or Temperature Sensor directly measures the temperature of the tube.

**Digital Multimeter**  
Measures thermistor resistance. (Sold separately)

### Features

- ▶ **Built-in Digital Gauge:** Measure the rod expansion with (0.01 mm resolution).
- ▶ **Built-in Thermistor:** A 10 kΩ thermistor is connected directly to each tube, and the temperature can be determined using a digital ohmmeter or Temperature Sensor.
- ▶ **Heat with Steam or Water:** The fluid used may be steam or water at any temperature.
- ▶ **Three Drop-in Metal Tubes:** Each tube connects securely onto the rigid base. The other two can be simultaneously mounted on the base for convenient storage.

### Includes

- Base with built-in dial gauge and thermistor
- Expansion tubes: Brass, copper and aluminum; 16 mm dia. (80 cm length)



*Thermistor cable connects directly to the Temperature Sensor.*

### Order Information

Thermal Expansion Apparatus .....	TD-8856	
<i>Required:</i>		
Steam Generator .....	TD-8556A	p. 191
<i>Recommended:</i>		
Digital Multimeter (ohmmeter) .....	SE-9786A	p. 241
<i>Or</i>		
Quad Temperature Sensor .....	PS-2143	p. 45

## Steam Generator

TD-8556A

- ▶ Variable steam output
- ▶ Rapid heating
- ▶ Automatic safety shut-off

Hot flowing steam is essential to most introductory thermodynamics experiments. It's inexpensive, plentiful, and the perfect constant temperature heat reservoir.

This Steam Generator brings 3/4 of a liter of water to a boil in ten minutes and provides continuous steam at up to 10 g/min. A baster is also provided to remove hot water for experiments. Includes many convenience and safety features.



See page 192-193 for additional Steam Generator applications.

### Order Information

Steam Generator..... TD-8556A

## Heater-Stirrer

PS-3401



- ▶ The Heater-Stirrer is the new lab essential!



This compact heater-stirrer has a white ceramic top that is ideal for heating and for seeing color changes when mixing solutions. It has been designed to withstand spills. Its safety features include warning labels and indicator LEDs. And the included rod makes it easy to support sensors.

### When used as a heater:

This compact new Heater-Stirrer can boil water in minutes. The ceramic top provides an even heating surface and the indicator LEDs let you know when the top is hot.

### When used as a stirrer:

This new apparatus is great for mixing solutions. The white top makes color changes during titrations easy to see.

### Specifications

- Speed range:** 50-1500 rpm
- Plate diameter:** 135 mm
- Max temperature:** 310°C

### Includes

- Support rod.

### Order Information

Heater-Stirrer..... PS-3401

# Thermal Conductivity

## Thermal Conductivity Apparatus

TD-8561

- ▶ Measure heat flow through five different materials
- ▶ Constant temperature differential makes calculations easy
- ▶ Easy to use, no mess



One of the most important considerations for buildings in the modern world is their ability to provide good thermal insulation. This apparatus gives students a way to observe and quantify heat flow across a constant temperature differential. Students use five common materials as test samples: glass, wood, polycarbonate, Masonite® and sheetrock.

### Features

- ▶ **No Mess:** Water from the melting ice runs off into the measuring cup — not on the lab table.
- ▶ **Durable Test Materials:** Wood, Masonite, and sheetrock are covered with a thin aluminum sheet for waterproofing and to ensure good thermal contact.
- ▶ **Elevated Steam Reservoir:** Hot reservoir is well above the lab table to eliminate heat damage.

### Order Information

Thermal Conductivity Apparatus..... TD-8561

Required:

Steam Generator..... TD-8556A p. 191

Graduated Cylinder

### How It Works

A block of ice is placed against one side of the test material. The other side is clamped against a steam chamber, establishing a constant 100°C temperature differential. The rate at which the ice is converted to water is a measure of the rate at which heat passes from the steam, through the test material, and into the ice.

### Includes

- Stand with insulating pads
- Steam chamber
- Ice molds (2)
- Materials: 12.7 cm squares of glass, wood, polycarbonate, Masonite, sheetrock
- Plastic tubing to connect steam generator
- Instruction manual and experiment guide

## Ice Melting Blocks

SE-7317

- ▶ Great thermal conductivity and heat capacity demonstration

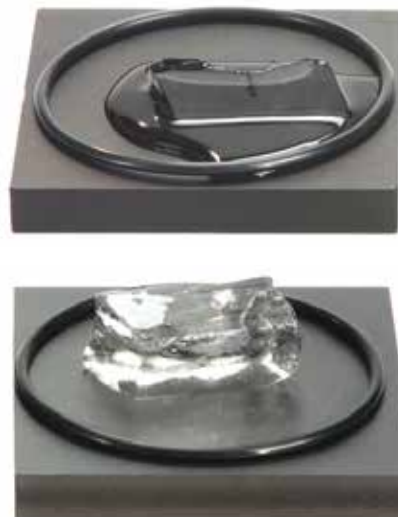

The two Ice Melting Blocks look similar, but are composed of different materials. One block feels cold to the touch, while the other block feels slightly warm. Both blocks are at room temperature but have very different thermal conductivities and heat capacities.

After allowing students to hold the blocks, ask them which block would melt ice more quickly. Place an ice cube on each block and watch their amazement as the “cold” block melts the ice cube within two minutes. Melting the ice cube is barely noticeable on the “warm” block. The “cold” block is aluminum and has a much greater ability to transfer heat to the ice cube or the hand. The “warm” block is plastic, which does not conduct heat as well.

### Includes

- Aluminum Block
- Plastic Block
- O-rings (2)



### Order Information

Ice Melting Blocks.....SE-7317

## Basic Calorimetry Set

TD-8557B

### ▶ An affordable introduction to thermodynamics

Styrofoam calorimeter cup (7.5 cm inside diameter, 10 cm deep) has 1.3 cm thick walls for excellent thermal properties. Set includes five different metal samples, a thermometer, plastic tubing, and a water trap that prevents unwanted condensation of steam.

#### Includes

- One calorimeter cup with lid
- Alcohol thermometer: 20°C to 110°C in 1° increments
- Samples of aluminum, copper, brass, zinc, and stainless steel: 80 g each
- Water trap and plastic tubing
- Instruction manual and experiment guide



#### Order Information

Basic Calorimetry Set ..... TD-8557B

#### Required:

Steam Generator ..... TD-8556A p. 191

Ohaus Triple-Beam Balance ..... SE-8723 p. 186

#### Replacement Supplies:

Calorimetry Cups (set of 6) ..... TD-8825A

## Specific Heat Set

SE-6849

This specific heat set has five different materials, all having the same mass (80 g). Each has a hole to tie a loop of string to hang the samples in water.



#### Includes

- Aluminum: 1.25" d x 1.5" h
- Brass: 3/4" d x 1.5" h
- Stainless Steel: 3/4" d x 1.44" h
- Zinc: 3/4" d x 1.58" h
- Copper: 0.625" d x 1.8" h

#### Order Information

Specific Heat Set ..... SE-6849

#### Recommended:

Calorimetry Cups (set of 6) ..... TD-8825A

## Density Set

ME-8569A

Use this versatile set of materials with the Overflow Can to investigate Archimedes' Principle of displacement, specific heats, and basic length/volume relationships.

Includes pieces that have the same shape, volume, density, and mass, so the variable of interest can readily be isolated. Each piece has a hole, so it can be suspended from a string.

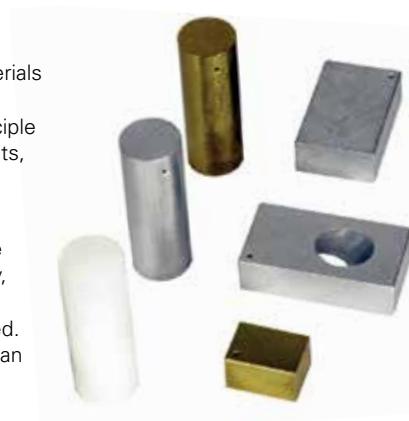

#### Includes

- Three cylinders: aluminum, brass, plastic; 2.2 cm dia. x 6.4 cm long (plastic is less dense than water)
- Two blocks: aluminum: 1.9 x 3.2 x 4.1 cm and brass: 1.6 x 1.9 x 2.8 cm. The mass of each block equals that of the aluminum cylinder; irregular shape: aluminum; instruction manual

#### Order Information

Density Set ..... ME-8569A

# Equivalent of Heat

## Mechanical Equivalent of Heat Apparatus

TD-8551A

- ▶ Accurate to 5%
- ▶ Rugged ball-bearing construction
- ▶ Thermistor— no thermometer to break

This Mechanical Equivalent of Heat Apparatus provides an updated version of one of Joule's most important experiments: converting mechanical work to thermal energy.

### Crank Counter

Counts the number of turns on the handle.

### Thermistor

Embedded in the cylinder, it has lower thermal mass than a thermometer and is less breakable.

**Double Ball-Bearings**  
Minimize the wear on moving parts.

**Durable Construction**  
Made primarily of steel and aluminum, there's virtually nothing to break. The thermistor is protected in the cylinder.

### How It Works

Turn the crank to perform a measurable amount of work. The crank turns an aluminum cylinder. A flat nylon rope is wrapped several times around the cylinder. As the crank is turned, the friction between the rope and the cylinder is just enough to support a mass hanging from the other end of the rope. This ensures that the torque acting on the cylinder is constant and measurable. A counter keeps track of the number of turns of the crank. The thermal energy is measured by monitoring the temperature of the cylinder using the embedded thermistor.

With this apparatus, the equivalence of work and heat is easily established to within 5%.

### Includes

- Base, cylinder, crank, and counter with a built-in table clamp
- 3.7 m of flat nylon rope
- 1-gallon can that can be filled with a measured mass of sand or water (if 10 kg of laboratory masses are not available)
- Laboratory manual including theory, step-by-step instructions, and data tables

### Order Information

Mechanical Equivalent of Heat Apparatus.....TD-8551A

#### Required:

Basic Digital Multimeter.....SE-9786A p. 241  
Triple-Beam Balance.....SE-8707 p. 186

*A refrigerator (or ice) for cooling the cylinder below room temperature. Calipers and a thermometer for measuring room temperature are helpful, but not necessary.*

#### Replacement Supplies:

Brush (single) .....TD-8583  
Cylinder.....TD-8582

## Energy Transfer – Calorimeter

ET-8499

- ▶ Compare electrical energy input to changes in internal energy

The Energy Transfer – Calorimeter includes two nested aluminum cups with an air space in between for insulation. While most calorimeters use a coil to heat the water, PASCO's design features a 10 Ω heating resistor mounted to a circuit board. Using temperature, voltage, and current sensors, students can investigate the relationship between the input energy and heat transfer into the water.

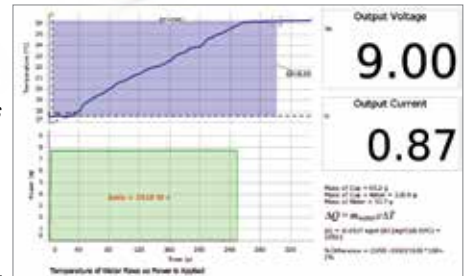

The bottom graph displays the power output from the generator and the top graph the increase in temperature. The amount of electrical energy used to heat to the water is determined by finding the area under the power versus time curve.

### Includes

- Outer Aluminum Cup (8.9 cm tall, 4.7 cm dia)
- Inner Aluminum Cup (7.5 cm tall, 3.8 cm dia)
- Plastic Lid
- Two-Hole Rubber Stopper
- Heating Resistor with Input Cables



### Order Information

Energy Transfer – Calorimeter.....ET-8499

#### Recommended for use with ScienceWorkshop:

Temperature Sensor.....CI-6605A p. 44  
Voltage Sensor.....UI-5100 p. 51  
Current Sensor.....CI-6556 p. 50

#### Recommended for use with PASPORT:

Temperature Sensor.....PS-2125 p. 44  
Voltage/Current Sensor.....PS-2115 p. 53

## Adiabatic Gas Law Apparatus

TD-8565

- ▶ Investigate the compression of gases
- ▶ Computer monitors temperature, pressure, and volume



**Volume Transducer**  
A linear potential divider monitors the position of the piston.

**Three Signal Cables**  
Carry the volume, pressure, and temperature signals to the computer.

**Temperature Sensor**  
Measures rapid changes in temperature as the resistance of a fine nickel wire changes.

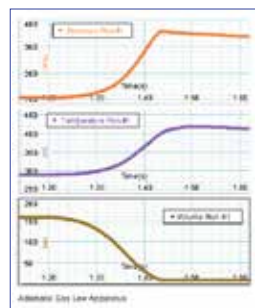

Students monitor pressure, temperature, and volume as a gas is compressed rapidly.

### Experiments

PASCO's Adiabatic Gas Law can be used with the 850 Universal Interface. The computer functions as a 3-channel storage oscilloscope, plotting graphs of pressure, temperature, and volume, as well as integrating the area under a pressure versus volume curve to determine the work done on the gas.

### Includes

- Adiabatic Gas Law Apparatus
- Instruction Manual, Experiment Guide
- Signal Cables: 3.5 mm plug to 5-pin DIN
- Power Adapter: 9 V DC @ 1 A

### Order Information

Adiabatic Gas Law Apparatus..... TD-8565

**Required:**

PASCO Capstone Software..... pp. 18-20  
A computer with an interface that will accept three analog signals simultaneously via 5 or 8-pin DIN connectors such as PASCO's 550 and 850 Interfaces.

## Compression Igniter

TD-8577

- ▶ Adiabatic compression ignites paper!
- ▶ Works every time
- ▶ Durable and cleanable

Put a small piece of tissue paper into the cylinder and quickly push down on the piston. In a quick compression there is no time for heat to be exchanged between the air inside and its surroundings, causing the temperature to rise well above the combustion temperature of paper.

Students will be amazed to see the paper catch on fire without a match.

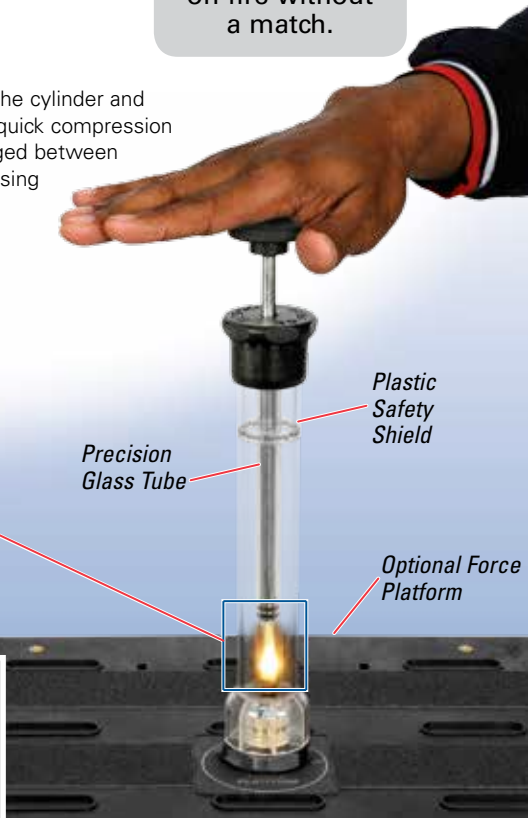
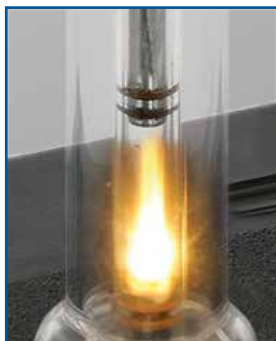

This Compression Igniter has been specially designed to be cleanable. The bottom screws off to clean out the soot and to load the paper. The large piston handle decreases the pressure on your hand and makes it easier to hit the piston quickly.

The glass tube is surrounded by plastic for safety. In the event that the glass tube breaks, the glass tube can be replaced.

### Includes

- Compression Igniter
- Spare Glass Tube with "O" Rings
- Cleaning Wire
- Complete Instructions with Theory

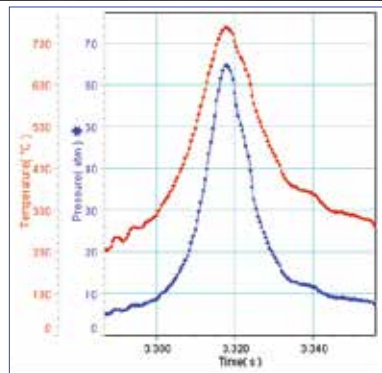

Pressure data is calculated using the force measured by the Force Platform. Assuming Adiabatic, the data shown gives a compression ratio of nearly 20:1, and a peak temperature of over 700 °C.

### Order Information

Compression Igniter..... TD-8577  
Replacement Tubes (2) ..... TD-8498A

Shown in use with:  
Force Platform (PASPORT)..... PS-2141 p. 31

## Gas Laws

## Ideal Gas Law Apparatus

TD-8596A

- ▶ Experimentally determine the Ideal Gas Law
- ▶ Large syringe for accurate volume measurements
- ▶ Built-in fast response thermistor

Investigating the Ideal Gas Law is simple using PASCO's Ideal Gas Law Apparatus. By connecting a Pressure Sensor and a Temperature Sensor to the syringe, students can quantitatively look at the relationships between pressure, temperature, and volume.

## How It Works

A low thermal mass thermistor is mounted within the syringe for real-time measurement of temperature changes inside the syringe. Tubing and a quick-connect port allows a Pressure Sensor to be directly connected to the syringe. As the plunger of the syringe is depressed, the volume decreases while pressure and temperature increase. The data will help students better understand the Ideal Gas Law.

$$PV = nRT$$

A mechanical stop is included on the syringe plunger to prevent damage of the thermistor within the syringe and to allow quick (adiabatic) volume changes.

Measures  
Temperature  
and  
Pressure

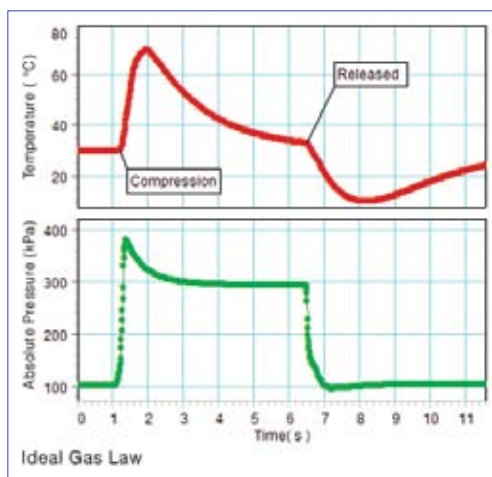

The measured values of Temperature and Pressure are used to calculate the Volume. The student can compare this calculated volume to the actual volume on the syringe in real-time.

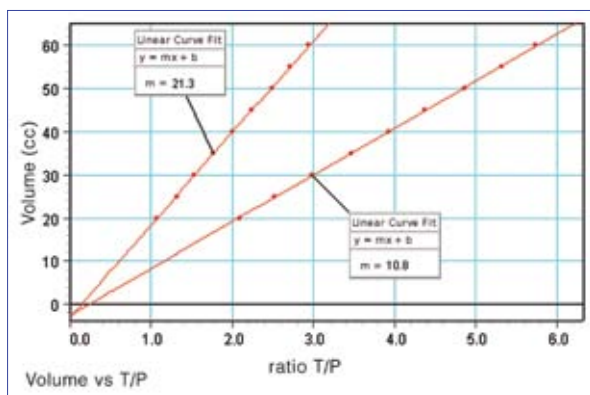

Slope of the Volume vs.  $\frac{T}{P}$  graph equals  $nR$ .

## Typical Applications

- ▶ Discover or verify the Ideal Gas Law
- ▶ Investigate relationships such as pressure vs. temperature (Gay-Lussac's Law), pressure vs. volume (Boyle's Law) and temperature vs. volume (Charles' Law)
- ▶ Calculate the number of moles of air in the syringe based on pressure, temperature, and volume measurements

## Includes

- Ideal Gas Law Syringe
- Built-in Fast Response Thermistor Probe
- Quick-Connect Pressure Port

## Order Information

Ideal Gas Law Apparatus.....	TD-8596A	
<i>Required for use with ScienceWorkshop:</i>		
Temperature Sensor.....	CI-6605A	p. 44
Absolute Pressure Sensor.....	CI-6532A	p. 40
<i>Required for use with PASPORT:</i>		
Pressure/Temperature Sensor.....	PS-2146	p. 42
<i>or</i>		
Temperature Sensor.....	PS-2125	p. 44
Absolute Pressure Sensor.....	PS-2107	p. 40
550 Interface.....	UI-5001	p. 14
PASCO Capstone Software.....		pp. 18-20

## Absolute Zero Apparatus

TD-8595

- ▶ Constant volume sphere
- ▶ Measure pressure and temperature directly using PASCO sensors
- ▶ Empirically determine the absolute zero temperature

The Absolute Zero Sphere is an effective tool for determining absolute zero temperature. Connect a Pressure Sensor and Temperature Sensor and immerse the sphere in water baths of several different temperatures. As the pressure and temperature change, a graph displays these changes in PASCO Capstone™. Once the data is collected, students can use a linear fit to extrapolate the value of absolute zero.

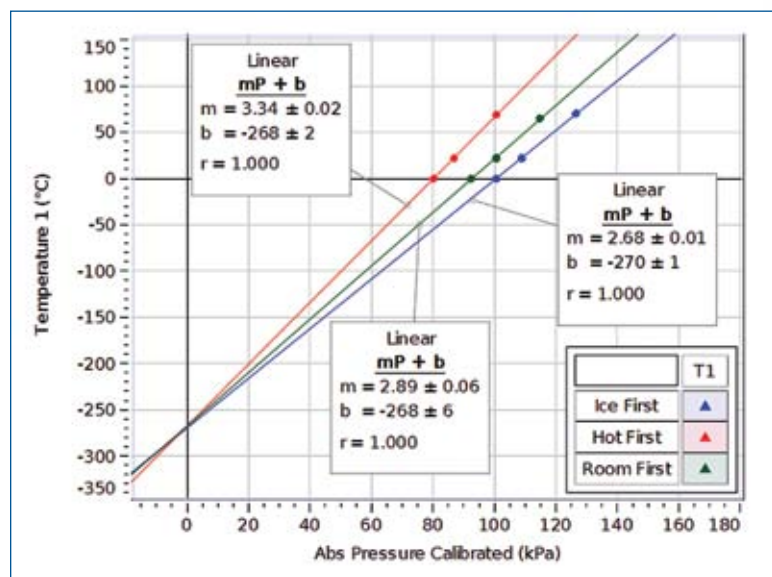

Absolute Zero Apparatus being used with PASPORT Pressure/Temp Sensor.

Temperature and pressure data is taken for three temperature water baths. The experiment is repeated with a different amount of gas initially in the sphere. The slopes of the two graphs reflect the change in the number of moles of gas, and both graphs extrapolate to about the same value for absolute zero.

### Typical Applications

- ▶ Experimentally determine the temperature of absolute zero
- ▶ Investigate the relationship between pressure and temperature (Gay-Lussac's Law)
- ▶ Discover the Ideal Gas Law

### Includes

- Absolute Zero Sphere
- Built-in Fast Response
- Thermistor Probe
- Quick Connect Pressure Port

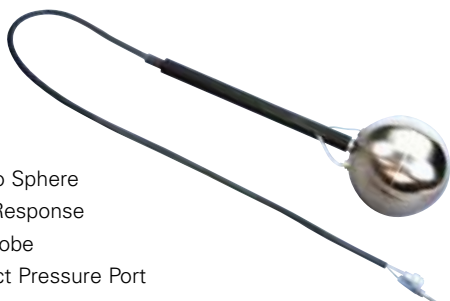

### Order Information

Absolute Zero Sphere .....	TD-8595
<i>Required for use with ScienceWorkshop:</i>	
Temperature Sensor .....	CI-6605A p. 44
Absolute Pressure Sensor .....	CI-6532A p. 40
<i>Required for use with PASPORT:</i>	
Pressure/Temperature Sensor .....	PS-2146 p. 42
<i>or</i>	
Temperature Sensor .....	PS-2125 p. 44
Absolute Pressure Sensor .....	PS-2107 p. 40
550 Universal Interface .....	p. 14
PASCO Capstone Software .....	pp. 18-20

## Heat Engine

## Heat Engine/Gas Law Apparatus

TD-8572A

- ▶ Near-frictionless piston and cylinder system
- ▶ Demonstration or computer data collection
- ▶ Heat Engine and Gas Law experiments

Here is an affordable, general-purpose apparatus for quantitative experiments involving the Ideal Gas Law and for investigations of a working heat engine.

Features a nearly friction-free piston/cylinder system. The 32.5 mm diameter graphite piston fits snugly into a precision-ground Pyrex® cylinder so that the system produces almost friction-free motion of 10 cm and minimal leakage.

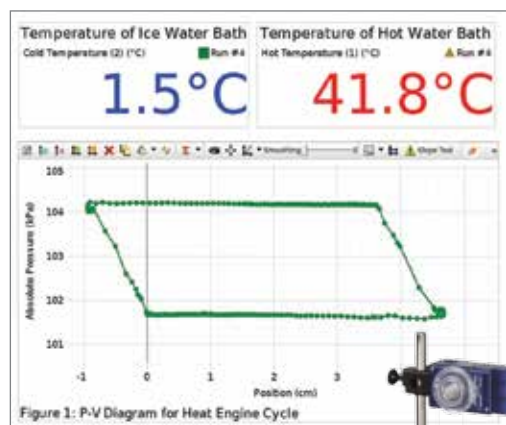

The PASCO Capstone™ graph shows an isobaric/isothermal heat engine cycle operating between a cold water bath at 1.5°C and a hot water bath at 41.8°C.



**Mass Platform**  
Add a mass to do work experiments. Use as a target for Motion Sensor to measure piston height.

**String Attachment Point**  
Connect Rotary Motion Sensor to track piston height.

**Rod Clamp Mount**  
Mount engine on a rod stand.

**Precision-bore Pyrex Cylinder Inside a Protective Plastic Shield**

**Locking Screw**  
Secures piston in any position for fixed volume.



**Air Chamber**  
Immerse in hot or cold water. All necessary tubing is included.

**Ultra-Low-Friction Graphite Piston**

**Quick-Connect Port**  
Connects to the air chamber tubing and a Dual Pressure Sensor.

### Measure the actual efficiency of a real heat engine, and bring the concept of P-V diagrams to life

- ▶ PASCO Heat Engine: Extracts heat from a large hot-water reservoir and does work to lift a weight.
- ▶ Real-time Graph: The heat engine cycle is traced on a Pressure vs. Volume graph as the engine goes through each part of its cycle, closing the cycle as waste heat is exhausted to the ice-water reservoir.
- ▶ Heat Engine Efficiency: Students compare the area inside the P-V cycle to the actual work done lifting the weight, and see how the efficiency of this heat engine compares to the theoretical maximum.

When the air chamber is moved from the cold water bath to the hot bath, the piston moves up and lifts the 200 g mass, doing work. The mass is removed, and then the air chamber is returned to the cold bath, creating an isobaric/isothermal cycle.

Give meaning to the abstract drawing of a heat engine cycle and let your students see the connection to the real world.

### Specifications

**Piston diameter:** 32.5 mm

**Maximum piston displacement:**  $\approx 10$  cm

### Includes

- Heat Engine
- Air Chamber
- Rubber Stopper with hole
- Tubing with Quick
- Connect Fittings
- Shut-off Valve

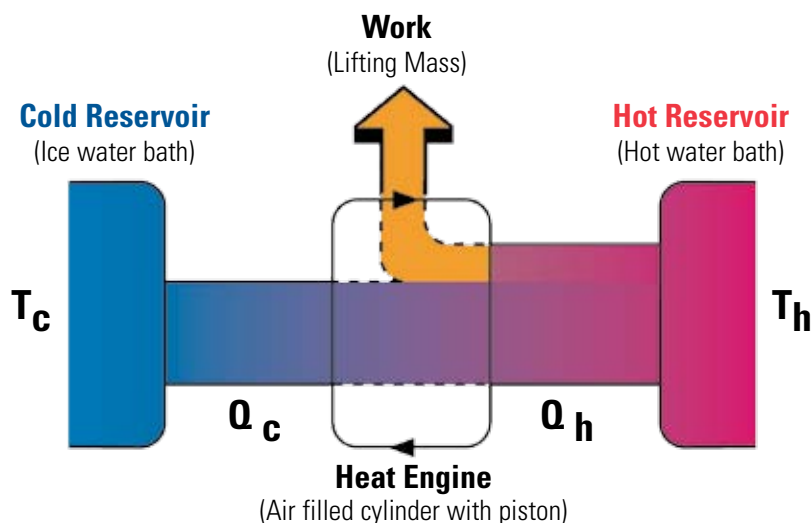

### Order Information

Heat Engine/Gas Law Apparatus..... TD-8572A

*Shown in use with:*

850 Universal Interface.....	UI-5000	p. 12
Dual Pressure Sensor.....	PS-2181	p. 41
Rotary Motion Sensor.....	PS-2120A	p. 25
3 Liter Plastic Container Set (2).....	ME-7559	p. 185
Small "A" Base.....	ME-8976	p. 176
60 cm Rod.....	ME-8977	p. 176

## Heat Engine Accessory

TD-8581A

This replacement kit includes the set of parts for the Heat Engine (suitable for both versions TD-8572 and TD-8572A) that are most likely to need replacement after extensive use. These parts connect the air chamber and the pressure sensor to the Heat Engine.

### Includes

- 1 Air Chamber
- 1 Rubber Stopper #10 with hole
- 2 Male Luer Lock Barbs
- 2 Female Luer Lock Barbs
- 1 Tube Connector 3/16X1/8"
- 1 Plastic Tee for 1/8" Tubing
- 1 One-way Stopcock
- 2 Female In-line 1/8" CPLG
- Polyurethane Tubing 1/8" ID 80 cm



### Order Information

Heat Engine Accessory..... TD-8581A

## Heat Engine

## Glass Stirling Engine

SE-8636A



See the pistons at work and look inside the glass cylinders at the Stirling Cycle principle in action. This engine is extremely interesting to watch and it is connected to a generator that lights LEDs. To illustrate the versatility of a Stirling Engine, we provide a burner for denatured alcohol and a platform for solid fuel.



Both cylinders are transparent so the action of the pistons can be viewed.

## Features

- ▶ Clear cylinders for viewing pistons
- ▶ Generator with LEDs
- ▶ Replaceable, adjustable Pyrex® heat cap
- ▶ Replaceable Pyrex power cylinder
- ▶ Solid hardwood platform
- ▶ Completely assembled and ready to run

## Specifications

18 cm length x 8 cm height x 9 cm width

## Order Information

Glass Stirling Engine ..... SE-8636A

## Thermoelectric Converter

TD-8550A

- ▶ Demonstrate the First Law of Thermodynamics
- ▶ Reversible

## Features

- ▶ Demonstrates that a temperature differential is essential for extracting usable energy
- ▶ Produces electrical energy from a temperature differential
- ▶ Produces a temperature differential with electrical energy
- ▶ 15 cm tall with 6 cm diameter fan

## How It Works

The Thermoelectric Converter uses a series of semiconductor thermoelectric cells to convert thermal energy into electrical energy. The output from the cells drives a small electric motor.

## Heat to Electrical Energy

Place one leg of the Thermoelectric Converter into cold water, the other into hot. The fan turns as the converter draws energy from the hot source (typically a 50°C temperature differential is required).

## Electrical Energy to Heat

Pass a current (3 A DC at 5 V) through the Thermoelectric Converter. It acts as a heat pump. One leg becomes warmer while the other becomes cooler.



When a temperature differential is established between the two legs, the fan turns.

## Order Information

Thermoelectric Converter ..... TD-8550A

## Required:

Containers for holding hot water, cold water, etc.

Triple Output Power Supply ..... SE-8587 p. 233

Partial Immersion Thermometer ..... SE-9084B p. 201

## FLIR C3 Thermal Imaging Camera

SE-7128A

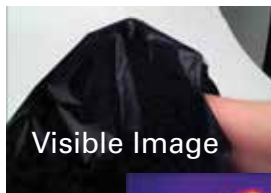

Visible Image

Hand inside black garbage bag.



Infrared Image

- ▶ “See” into the infrared
- ▶ Simultaneously record visible and infrared snapshots
- ▶ Stream video using FLIR tools
- ▶ Record infrared movies in PASCO Capstone
- ▶ Determine temperatures from color coding
- ▶ WiFi enabled

Extend your students’ world into the infrared with this full-featured, pocket-sized thermal camera. This infrared camera takes two pictures at once: One in the visible spectrum and one in the infrared. An outline of the visible image is superimposed on the colorized infrared picture for reference. In addition to the color temperature scale there is a digital readout of the temperature. All of this is offered at a special educator’s price.

### Consider these activities:

- ▶ Check light transmission through different media: Visible light easily passes through acrylic; IR doesn’t. Visible light is not readily transmitted through black balloons, but they are transparent in the IR, as are silicon wafers and black plastic garbage bags.
- ▶ Slide a block on the table. We always tell our students that the energy is dissipated as heat. Show them!
- ▶ Look at your infrared reflection on a white board.
- ▶ Record infrared video in PASCO Capstone and sync to data from thermal experiments.
- ▶ Take off your shoes and follow your footsteps by looking at your infrared footprints.
- ▶ Evaluate different types of insulation.
- ▶ Measure the temperature of ice water.
- ▶ Beakers of water with different temperatures (as measured with the camera) come to some easily predictable temperature when mixed together.

### Key Features

1. Light, slim profile
2. Bright 3” touchscreen
3. Built-in LED work light and flash
4. Big snapshot button stores thermal, visible, and visible overlay in each JPEG
5. Easy-access on-off button powers up fast
6. USB Micro-B file transfer and data streaming
7. Visible camera
8. Thermal camera
9. Intuitive user interface

### Specifications

#### 3” touchscreen

**IR sensor:** 80 x 60 pixels

**Digital camera:** 640 x 480 pixels

**Temperature reading** at each of the 4,800 pixels

**Temperature range:** -10°C to 150°C

**Accuracy:** ±2°C or 2%, whichever is greater

**Onboard memory** stores 500 sets of jpeg images

**USB Micro-B connector**

**WiFi**

**Rechargeable Li-ion polymer battery** with 2 h operating time

**Weight:** 0.13 kg (0.29 lb)

**Size (L x W x H):** 12.5 x 8.0 x 2.4 cm

**2-year warranty** on parts and labor

**10-year warranty** on detector



### Includes

- FLIR C3 thermal imaging camera
- Tripod mount
- Power supply/charger
- USB cable
- ResearchIR software
- Access to FLIR education content with lectures, experiments, and teacher’s guides

### Order Information

FLIR C3 Thermal Imaging Camera.....SE-7128A

## Partial Immersion Thermometer

SE-9084B

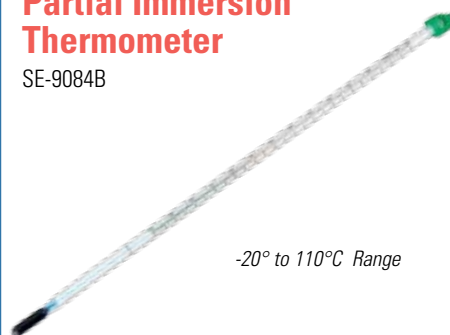

-20° to 110°C Range

Features 1°C accuracy or better. Filled with environmentally safe non-toxic, non-hazardous, biodegradable Enviro-Safe® liquid. Measure from -20° to 110°C with this 30 cm long thermometer. It is clearly marked at 1 degree intervals, and a ring on top allows students to suspend it from a string.

### Order Information

Partial Immersion Thermometer .....SE-9084B

## Non-Contact Temperature Sensor

PS-2197



- ▶ Non-contact
- ▶ -70°C to 380°C

The Non-Contact Temperature Sensor measures surface temperature by detecting the emitted infrared light. Record the temperature of objects without touching them!

### Typical Applications

- ▶ Compare temperature of hands, skin, face, and clothes
- ▶ Measure the temperature of different outdoor ground surfaces
- ▶ Map the temperature profile of an exterior wall

### Specifications

**Range:** -70°C to 380°C

**Accuracy:** ±0.5°C

**Response Time:** Less than 0.1 s

**Maximum Sample Rate:** 200 Hz

**Field of View:** ±35°

### Order Information

Non-Contact Temperature Sensor.....PS-2197  
Requires an Interface (see pages 10-11)

See a variety of Temperature Sensors on pages 44-46.

# Radiation

## Radiation Cans

TD-8570A



These three aluminum cans have different surface finishes: silver (unpainted), white, and flat black. They are 15 cm high and hold about 350 ml of water. Their large thermal mass ensures good results with both temperature probes and standard glass thermometers. Fill them with cool water and place them outside in the sunlight to investigate the effect of the surface finish on solar heating. Or place them inside filled with hot water to discover Newton's Law of Cooling. (*Wireless temperature probes not included.*)

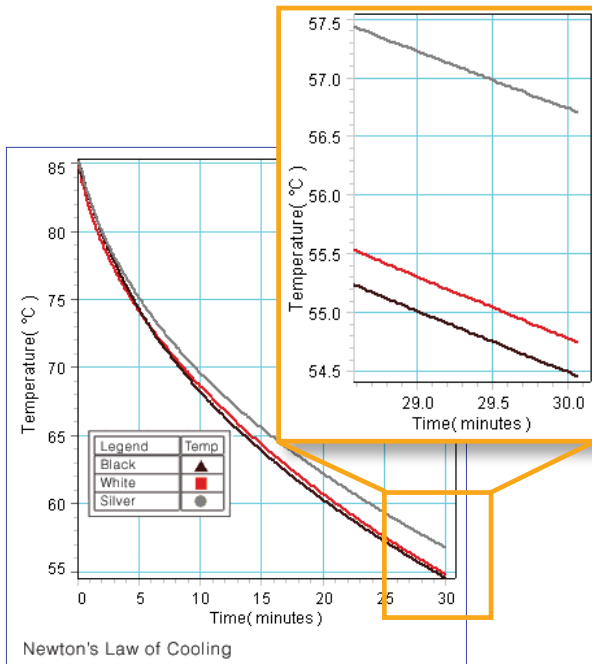

The black, white, and silver Radiation Cans are filled with hot water and allowed to cool. Graphs made in PASCO Capstone.

### Order Information

Radiation Cans (set of three) .....TD-8570A  
 Required to measure temperature:  
 Wireless Temperature Sensor.....PS-3201 p. 46  
**OR**  
 Partial Immersion Thermometer .....SE-9084B p. 201

## Thermal Radiation Cube (Leslie's Cube)

TD-8554A

► Low-temperature radiation source

### Features

- **Electrically Heated:** The 100-watt bulb inside eliminates the danger of an open flame and the inconvenience of water-heated cubes.
- **Thick Aluminum Walls**
- **Thermistor:** A 100 kΩ thermistor embedded in one wall for temperature measurement.



### Order Information

Thermal Radiation Cube ..... TD-8554A  
 Required:  
 Radiation Sensor.....TD-8553  
 Basic Digital Multimeter.....SE-9786A p. 241

## Radiation Sensor

TD-8553

- Radiation detector
- Thermopile

Point the Radiation Sensor toward any object – open the shutter and read the digital voltmeter to measure the relative intensity of the thermal radiation emitted.



### Flat Spectral Response:

0.6 to 30 μm

### Order Information

Radiation Sensor.....TD-8553  
 Required:  
 Basic Digital Multimeter.....SE-9786A p. 241

## Stefan-Boltzmann Lamp

TD-8555

► A high-temperature radiation source

The temperature of this 12-V incandescent lamp filament can be accurately determined by measuring the voltage and current that students supply to the lamp (a graph of temperature versus resistivity is provided).



### Order Information

Stefan-Boltzmann Lamp ..... TD-8555  
 Required:  
 12-V DC Power Supply – See p. 235

## Thermal Radiation Laboratory

TD-8855



With the Radiation Sensor, a versatile Radiation Cube, and the Stefan-Boltzmann Lamp, four key experiments in thermal radiation can be performed.

Students begin with a study of thermal radiation from different types of surfaces at the same temperature. The Thermal Radiation Cube has four different surfaces that can be monitored (black matte, white matte, polished aluminum, and dull aluminum). The cube is heated electrically with a 100-watt bulb (its output can be varied). The thick aluminum walls assure the same temperature on all four walls to within a fraction of a degree. The Radiation Sensor provides

an accurate measure of thermal radiation throughout the infrared region. Its output is a voltage that is proportional to the intensity of radiation.

Another important introductory experiment is the Inverse Square Law. The Stefan-Boltzmann Lamp uses a special bulb to provide a near-perfect point source, providing accurate results.

Finally, students can verify the Stefan-Boltzmann Law for both low and high temperatures by using the Radiation Cube for the low temperatures and the Stefan-Boltzmann Lamp for the high temperatures.

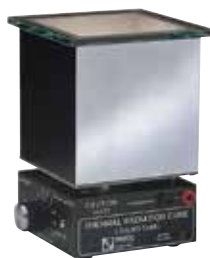

### Typical Experiments

With Teacher's Guide and Sample Data.

1. Introduction to Thermal Radiation
2. Stefan-Boltzmann Law at Low Temperatures ( $R_{\text{rad}} = \sigma T^4$ )
3. Inverse Square Law
4. Stefan-Boltzmann Law at High Temperatures



To see the experiments, type the product number into the search box at [www.pasco.com](http://www.pasco.com) and download the manual.

### Includes

- Thermal Radiation Cube
- Stefan-Boltzmann Lamp
- Radiation Sensor

See previous page for component details.

### Order Information

Thermal Radiation Laboratory .....	TD-8855	
<i>Required:</i>		
Basic Digital Multimeter .....	SE-9786A	p. 241
Low Voltage Power Supply .....	SF-9584B	p. 235
<i>Shown in use with:</i>		
2 Meter Patch Cord Set .....	SE-9415A	p. 186

# Van de Graaff Generator

## Van de Graaff Generator, High Voltage

SE-8691

- ▶ Large sphere creates higher voltage
- ▶ Sparks up to 35 cm in length
- ▶ Large size ideal for demonstrations

The High Voltage Van de Graaff Generator features a 25 cm diameter sphere that can generate approximately 400,000 volts. The size of the sphere, its rounded edges, and its height from the demonstration table contribute to the high voltages generated.

Its large size, long sparks, and high voltages make it ideal for use in larger rooms or lecture halls. An extra belt is included.



## Electric Plume

SE-7232

The lightweight ribbons are connected to a stand that rests on top of the Van de Graaff Generator. As the generator operates, the ribbons stand on end, due to the repulsive force between their like charges.



## Discharge Sphere

SE-7231



This 25 cm sphere is supported on a Lucite® column with a cast iron base. Includes cabling for connection to the Van de Graaff Generator or to a ground.

## Electric Whirl

SE-7233



When held near the sphere of the generator, the spokes are propelled by charge leaving the points.

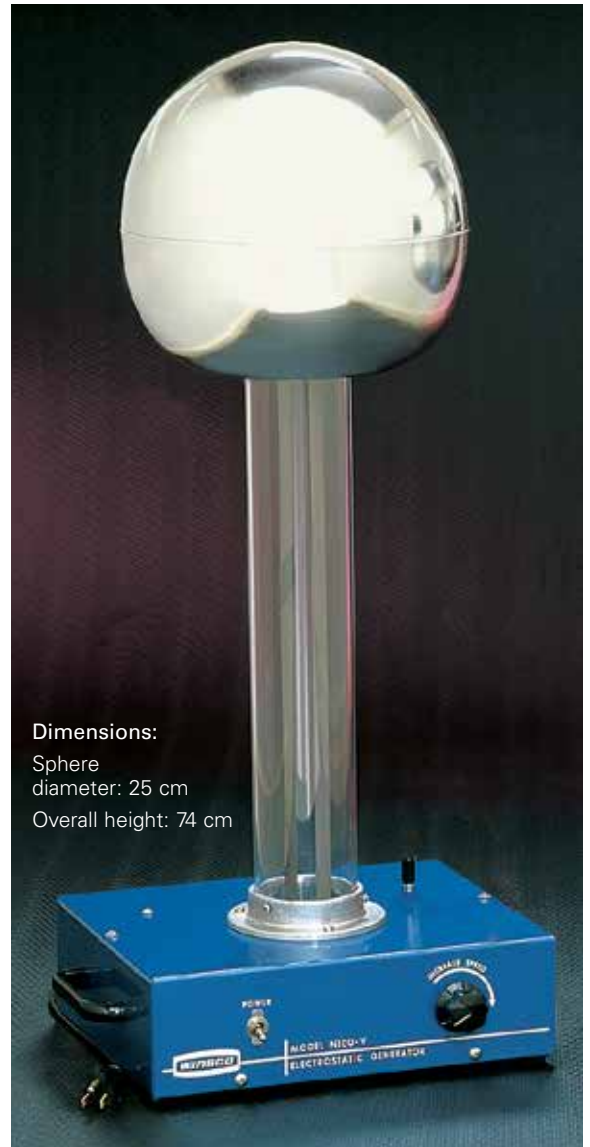

Dimensions:

Sphere diameter: 25 cm

Overall height: 74 cm

## Van de Graaff Replacement Belt



### Order Information

Replacement Belt ..... SE-7355

### Order Information

Van de Graaff Generator,  
High Voltage..... SE-8691  
Electric Plume ..... SE-7232  
Discharge Sphere..... SE-7231  
Electric Whirl..... SE-7233  
*Replacement Supplies:*  
Replacement Belt ..... SE-7355

## Charge, Equipotential and Field Mapper

ES-9060



The Charge, Equipotential, and Field Mapper is an excellent addition to the Basic Electrostatics System.

Draw any set of two-dimensional conductors with the conductive ink. Investigate the electric field and the equipotential field lines between and around the conductive paper to any shape. Charge it and investigate the distribution of charge on its surface.

Similar to the Field Mapper Kit, except it includes electrometer probes, a "point charge" holder, and larger sheets of conductive paper for investigating charge distributions on conductive surfaces.

### Includes

- Conductive paper for mapping charge distributions: 30 x 45 cm (50 sheets)
- Conductive paper with cm grid for mapping equipotentials and field gradients: 23 x 30 cm (100 sheets)
- Pushpins (10), connecting wire (1) and electrometer probes (2)
- Conductive ink pen and a circular template for drawing conductors
- "Point charge" holder
- Plastic tray with corkboard top: 32 x 48 cm
- Manual with 13 experiments

### Order Information

Charge, Equipotential, and Field Mapper ..... ES-9060

#### Replacement Supplies:

Conductive Ink Pen ..... PK-9031B  
(limited shelf life of six months; pen is not refillable)

Conductive Paper with grid  
(50 sheets, 23 x 30 cm) ..... PK-9025

Conductive Paper (no grid)  
(100 sheets, 30 x 43 cm) ..... PK-9026

## Field Mapper Kit

PK-9023

### Conductive Paper

Printed grid makes measurements easy.



### Storage Tray

After the lab, everything stores neatly under the corkboard.

### Cork Surface

Use pushpins to hold the paper during the experiment.

### Conductive Pen

Draw any shaped charge electrode with this conductive ink pen.

Start by investigating standard electrostatic configurations, such as point sources, dipoles, and capacitors. Then go further. You might, for example, investigate whether a person is safe in a car, under a tree, or on top of a flag pole in a thunder storm. Or you might create an electrostatic model of fluid flow to show that water flows fastest in the narrowest portion of a hose.

### How It Works

With this kit students can map both the potentials and the electric fields around any conceivable system of two-dimensional charged conductors.

### The procedure is simple:

1. Draw any electrode
2. Plot the equipotentials
3. Plot the electric field

### Features

- ▶ Complete kit
- ▶ Complete manual
- ▶ Measure electric fields directly
- ▶ Measure potentials directly
- ▶ No mess
- ▶ Inexpensive
- ▶ Easy storage

## Special Conductive Ink Pen

PK-9031B

The PASCO Conductive Silver Ink Pen makes it easy to study field patterns. Draw over 60 meters of patterns with a single pen. Pen shelf life is six months. Not refillable.

### Order Information

Conductive Ink Pen ..... PK-9031B

*\*Price may fluctuate with the price of silver.*



### Typical Experiments

1. Dipoles of Like Charges
  2. Dipoles of Opposite Charges
  3. Parallel Plate Capacitor
  4. Point Source and Guard Ring (cylindrical capacitor)
  5. Floating Electrode
- Plus five more experiments.



To see the experiments, type the product number into the search box at [www.pasco.com](http://www.pasco.com) and download the manual.

### Includes

- Conductive paper with cm grid: 23 x 30 cm (50 sheets)
- 10 pushpins; three wires
- Conductive ink pen and circular template
- Plastic tray with corkboard top: 32 x 48 cm
- Instruction manual with 10 experiments

### Order Information

Field Mapper Kit ..... PK-9023

#### Required:

Basic Digital Multimeter ..... SE-9786A p. 241  
(or any voltmeter with at least a 10 M $\Omega$  input impedance)

Power Supply ..... SE-8587 p. 233  
(or another low voltage DC power supply or battery)

Replacement Supplies:  
Conductive Ink Pen ..... PK-9031B  
(limited shelf life of six months; not refillable)

Conductive Paper with grid  
(50 sheets, 23 x 30 cm) ..... PK-9025

Conductive Paper (no grid)  
(100 sheets, 30 x 43 cm) ..... PK-9026

# Electrostatics Systems

## Basic Electrostatics System

ES-9080B

- ▶ Quantitative electrostatics
- ▶ Comprehensive experiment manual included
- ▶ Individual or demonstration use

The PASCO Basic Electrostatics System includes all the components necessary for a quantitative investigation into the basics of electrostatics. With this integrated set of equipment, students can study:

- ▶ Production of charges, equal and opposite
- ▶ Charge by induction
- ▶ Principle of the Faraday Ice Pail
- ▶ Charge transfer
- ▶ Charge distribution in electric fields
- ▶ Capacitors and the  $Q=CV$  relationship
- ▶ Moving charges and current



### Includes

- Basic Electrometer ES-9078A
- Charge Producers and Proof Plane ES-9057C
- Faraday Ice Pail and Shield ES-9042A
- Conductive Spheres, 13 cm ES-9059C
- Conductive Shapes ES-9061
- Basic Variable Capacitor ES-9079
- Electrostatics Voltage Source ES-9077
- Experiment Manual

### Order Information

Basic Electrostatics System.....ES-9080B

## Basic Electrometer

ES-9078A

The PASCO Basic Electrometer is a quantitative electrostatic voltmeter, measuring the polarity and magnitude of charged objects. With almost infinite input resistance ( $10^{14}$  ohm), the Electrometer is a high-impedance voltmeter, draining almost no charge from the object it is measuring.

### Features

#### Center-Zero Meter:

Polarity is indicated directly.

#### 3, 10, 30, and 100 VDC

#### Switch-Selectable Ranges:

LED lamps indicate the range in use.

**Zeroing Switch:** For removing all charge from the input and bringing the meter to zero.

**Automatic Shutoff:** Unit turns off about three hours after being used.

#### Output compatible with the 850 Universal Interface and ScienceWorkshop Interfaces:

For recording data or producing a demonstration-sized meter display.

**Battery Operation:** Uses four "AA" cells (included). Range indicator lights flash when batteries need to be replaced.

### Includes

- Shielded input cable to connect the Electrometer to the Faraday Ice Pail or other source of charge
- Grounding cable with clip
- Interface cable
- Instruction and experiment manual

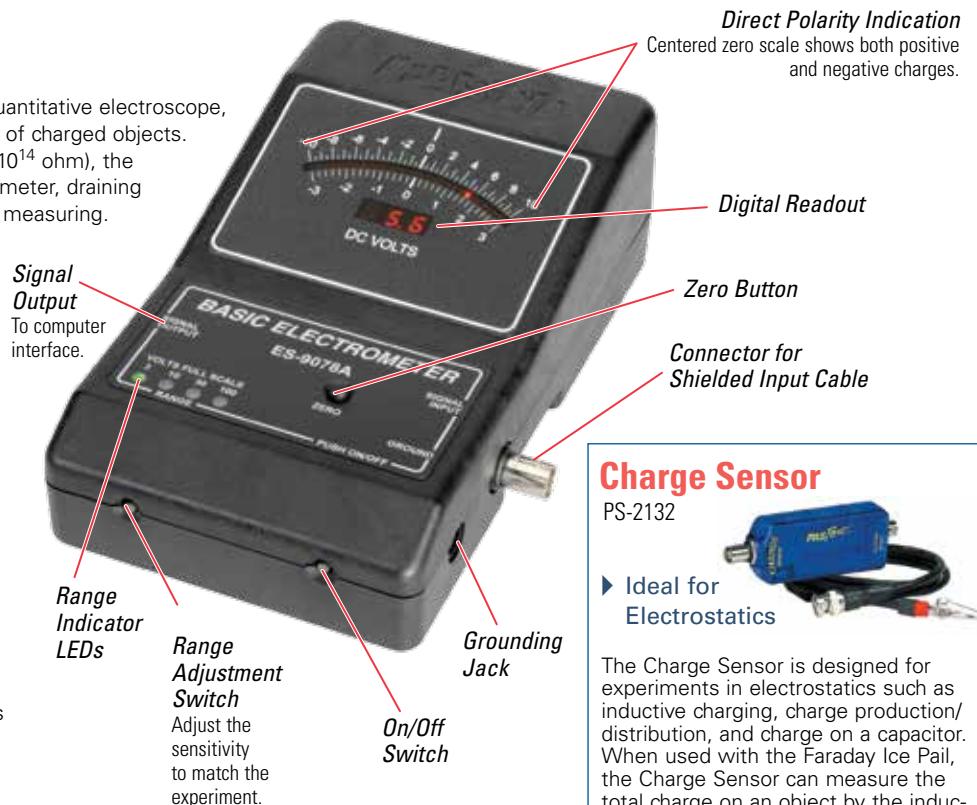

## Charge Sensor

PS-2132

- ▶ Ideal for Electrostatics



The Charge Sensor is designed for experiments in electrostatics such as inductive charging, charge production/distribution, and charge on a capacitor. When used with the Faraday Ice Pail, the Charge Sensor can measure the total charge on an object by the induction method.

The Charge Sensor can also be used as a high impedance voltmeter ( $10^{12} \Omega$ ). See page 51 for more information.

### Order Information

Charge Sensor.....PS-2132

### Order Information

Basic Electrometer.....ES-9078A

## Electrostatics Voltage Source

ES-9077



This compact unit is ideal for performing experiments in electrostatics. It may be used as a source of charge or to maintain an object at a constant potential.

Output voltages are 1000, 2000, and 3000 VDC for charging spheres, capacitor plates, etc. A 30 VDC source is also provided for experiments with capacitors.

### Specifications

**Output:** 30, 1000, 2000, 3000 VDC  $\pm 3\%$ , line regulated

**Resistance in Series with Output:** 120 M $\Omega$ /kV

**Operating Voltage:** 115/220, 50/60 Hz

**AC Adapter:** 9 VDC

### Order Information

Electrostatics Voltage Source..... ES-9077

## Basic Variable Capacitor

ES-9079

Two 18 cm diameter plates allow the capacitance to be varied from 225 pF to zero by sliding the movable plate in its 28 cm long track. The sliding plate has adjustment screws to make the plates parallel to each other. Electrical connection studs are located on each plate.

A BNC connector cable is provided for connection to an Electrometer.



### Order Information

Basic Variable Capacitor ..... ES-9079

## Classic Electrostatics Materials Kit

SF-9068

Providing the classic introduction to electrostatics, this kit allows students to rub any of the three rods with rubbing cloths to produce a positive or negative charge. Place the rods on the insulated pivot stands to investigate electrostatic forces.

### Includes

- Three rods (acrylic, glass, PVC)
- Two insulated pivot stands
- Three rubbing cloths (wool, silk, fur)

### Order Information

Classic Electrostatics Materials Kit ..... SF-9068



## Conductive Spheres

ES-9059C

These Conductive Spheres (two per set) can be used to store charge or to investigate the charge distribution on one or two spherical conductors.

A terminal on the bottom of each sphere provides a connection point for the power supply. Each sphere is attached to a heavy base (for stability) with an insulating rod. The spheres are 13 cm in diameter and 30 cm high.

### Order Information

Conductive Spheres..... ES-9059C



## Charge Producers and Proof Plane

ES-9057C

The Charge Producers create equal positive and negative charges when rubbed together. The Proof Plane samples the charge density from a charged object. The charge can then be measured using the Electrometer and Faraday Ice Pail.

*Use the ball end to sample inside the hollow sphere.*



## Replacement Pad Set

ES-9056 (for ES-9057C)

### Includes

- Artificial leather pads (5)
- Blue vinyl pads (5)

### Order Information

Replacement Pad Set..... ES-9056

### Order Information

Charge Producers and Proof Plane ..... ES-9057C

## Conductive Shapes

ES-9061



This set includes a conductive sphere with a hole in it. Demonstrate that static charge resides outside the surface of a conductive sphere by sampling the inside surface with the ball end of the proof plane (on this page). Also included is an oblong shape for demonstrating the difference in charge densities on a large-radius surface versus a small-radius surface. The whole surface is at the same potential, and students seem surprised to find that the charge density is greater on the smaller end.

### Order Information

Conductive Shapes ..... ES-9061

## Faraday Ice Pail and Shield

ES-9042A

With the Faraday Ice Pail, students can use the Electrometer to measure charge as well as potential. Touch the Proof Plane to the point of interest on the charged body, then place the Proof Plane inside the Ice Pail. The Electrometer reading will be directly proportional to the charge on the Proof Plane.

The Faraday Ice Pail is 10 cm in diameter and 15 cm deep. It is made of wire mesh, so it is easy to see what is going on inside. The outside shield has a diameter of 15 cm.



### Order Information

Faraday Ice Pail ..... ES-9042A

## Electroscope

SF-9069

When this Electroscope is charged, the conductive rod rotates to indicate charge magnitude. The shield ring is 15 cm in diameter and can be grounded with banana plug connectors (not included).



### Order Information

Electroscope ..... SF-9069

## Circuits

# PASCO Modular Circuits

## Basic Modular Circuits Kit

EM- 3535

## Essential Physics Modular Circuits Kit

EM-3536

- ▶ Puts learning first
- ▶ Eliminates confusing wires
- ▶ Easy-to-connect modules

These circuit modules are designed specifically for introductory circuits classes. For students who have never wired a circuit, this modular system makes it easy for them to see the layout because it ends up looking like a circuit diagram.

Each module connects mechanically to another by sliding the tabs into each other. It works on any tabletop. No special surface is required. To electrically connect two modules, students insert a jumper clip, which emphasizes that an electrical connection has been made. The large size of the modules (8 cm x 8 cm) enables all the students around the table to see and understand the completed circuit.

Students learn the correct way to insert an ammeter into a circuit: First they remove one of the straight wire modules from their circuit and then they replace it with the Wireless Current Sensor Module. Since the Current Sensor Module is in the same form factor as the other modules, it naturally fits in series with the circuit components. The fact that the Current Sensor is wireless helps the pedagogy: There is only one way in and one way out of the Current Sensor. There are no extra wires coming out of it to confuse students.

*Believe it or not, these two circuits are the same. Which would be easier for your students to understand?*

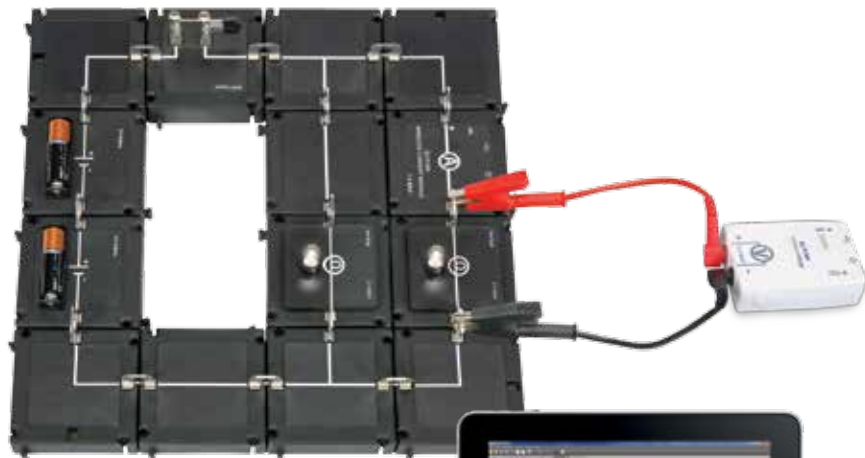
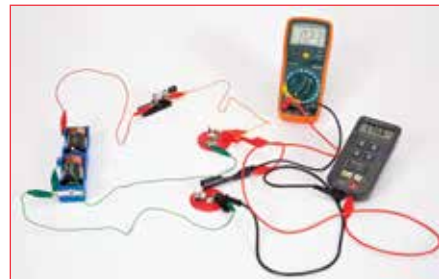

*The voltage and current are read on a tablet using SPARKvue or computer using Capstone.*

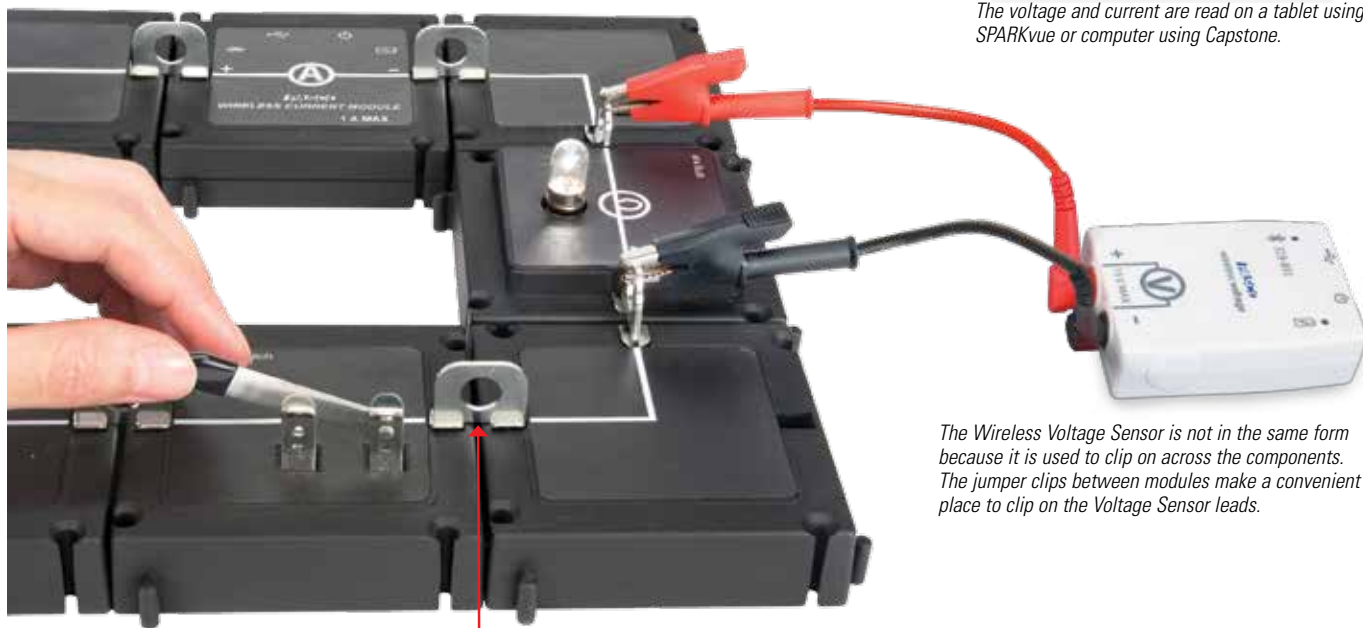

*The Wireless Voltage Sensor is not in the same form because it is used to clip on across the components. The jumper clips between modules make a convenient place to clip on the Voltage Sensor leads.*

*To electrically connect two modules, students insert a jumper clip, which emphasizes that an electrical connection has been made.*



Since the Current Sensor Module is in the same form factor as the other modules, it naturally fits in series with the circuit components.

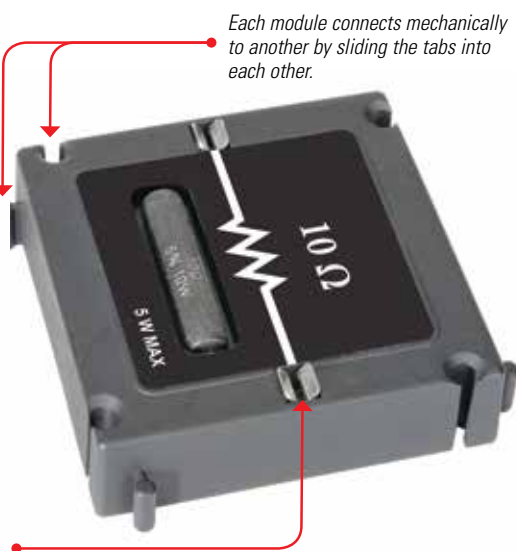

Each module connects mechanically to another by sliding the tabs into each other.

To make them visible, many of the components are mounted on top of the module or in a well for protection.

### Wireless Current Sensor Module EM-3534 (included in EM-3536) Specifications

- ▶ **Two Ranges:** ±1A, ±0.1A
- ▶ **Resolution:** 0.2mA (±1A range); 0.02mA (±0.1A range)
- ▶ **Bluetooth® sampling rate of 1 kHz**
- ▶ **Higher speed sampling via USB**
- ▶ **Includes remote logging**

### There are two kits.

The Basic Kit has enough modules to do the five basic experiments listed below. The Essential Kit has more modules, includes the Wireless Current Sensor Module and Wireless Voltage Sensor, and has 12 experiments.

### Basic Circuit Kit Experiments

- Ohm's Law
- Series/Parallel Circuits
- Batteries & Bulbs Circuits
- Switches/Open/Closed Circuits
- Electric Power and Energy

### Essential Circuit Kit Experiments

- Ohm's Law
- Series/Parallel Circuits
- Kirchoff's Laws
- Batteries & Bulbs Circuits
- Switches/Open/Closed Circuits
- Electric Power and Energy
- Electromagnets
- Electromagnetic Induction
- RC & RL circuits
- Variable Resistance
- LED Circuits
- Electric Motors

#### Includes

Module	Basic EM-3535	Essential EM-3536
Straight	4	5
Corner	4	4
Resistor	2	3
Light bulb	2	3
Tee	2	2
Battery Holder (batteries not included)	2	2
SPST	1	1
Capacitor	1	1
Spring Clips	1	1
Inductor	0	1
Motor	0	1
LED	0	1
Potentiometer	0	1
SPDT switch	0	1
Bar Magnet	0	1
Wireless Voltage Sensor	0	1
Wireless Current Sensor Module	0	1
Extra Jumpers	15	15
Loose Components for		
Spring Clips	5	5
Gratnell™ Case	1	1
Experiments (download)	5	12



Each kit comes in a Gratnell™ case with trays that organize the modules.

#### Order Information

- Basic Modular Circuit Kit .....EM-3535
- Essential Physics Modular Circuit Kit .....EM-3536
- Required:
- 2 AA Batteries
- Required for EM-3536:
- PASCO Capstone Software
- or SPARKvue Software .....See pages 18-20
- Also available separately:.....
- Wireless Current Sensor Module .....EM-3534
- Wireless Voltage Sensor .....PS-3211

## Circuits

## Charge/Discharge Circuit

EM-8678A

The Charge/Discharge Circuit offers a unique way to observe and measure the behavior of DC circuits including batteries, capacitors, light bulbs, and resistors. It also includes an open slot that allows a component to be inserted for further experimentation.

## Works Like a Variable DC Power Supply

Charge the capacitor using batteries and then the capacitor will act as a variable DC power source as you discharge it through a resistor or light bulb. Students measure the voltage and current as the capacitor discharges, and can graph the relationship between voltage and current for various components.

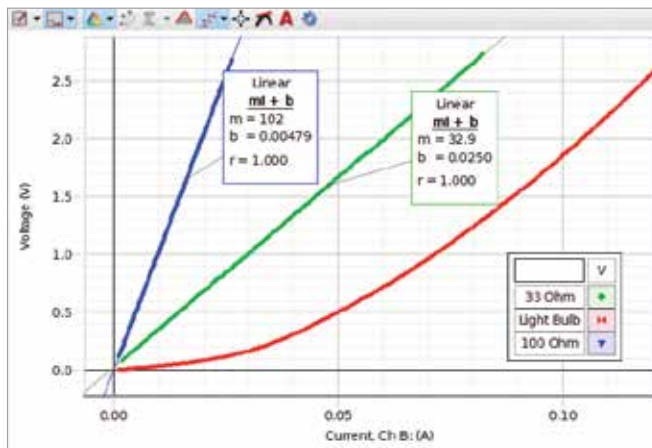

Voltage vs. Current for a  $33\ \Omega$  resistor, a  $10\ \Omega$  resistor, and a light bulb. Note the non-linearity for the bulb. Data was recorded in PASCO Capstone using a 550 Universal Interface, Voltage Sensor (UI-5100) and a Wireless Current Sensor (PS-3212).

## Includes

- 1 Farad Capacitor
- #14 Light Bulbs (3)
- $10\ \Omega$  Resistor
- $33\ \Omega$  Resistor
- $100\ \Omega$  Resistor
- Battery Holders (uses AA or AAA)
- Double-Throw Knife Switch
- Instruction Manual

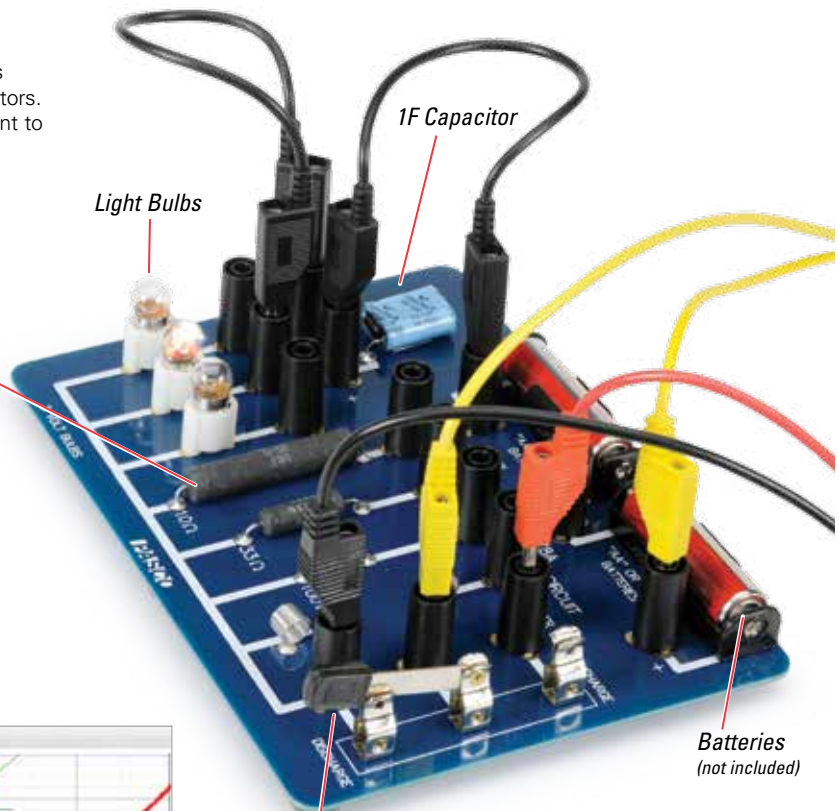

Charge/Discharge Switch

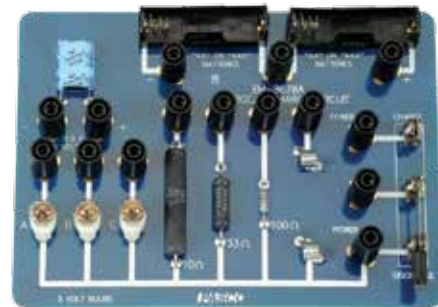

## Order Information

Charge/Discharge Circuit..... EM-8678A

Recommended:

#14 Light Bulbs (25 pack)..... EM-8627 p. 218

4-pack "AA" Batteries (not included)

Wireless Current Sensor..... PS-3212 p. 52

Wireless Voltage Sensor..... PS-3211 p. 52

PASCO Capstone Software

## Resistor Capacitor Inductor Network

UI-5210

Board components can be used to investigate Kirchhoff's circuit laws, Ohm's Law, RC circuits, and A.C. LRC circuit theory with resonant frequencies between 55 kHz and 135 kHz, depending on values used. (Designed for the 850 Universal Interface)

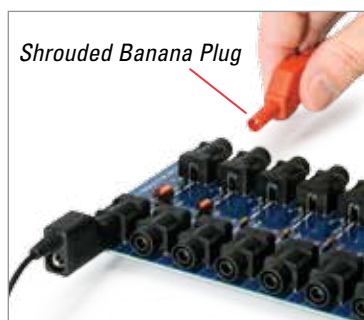
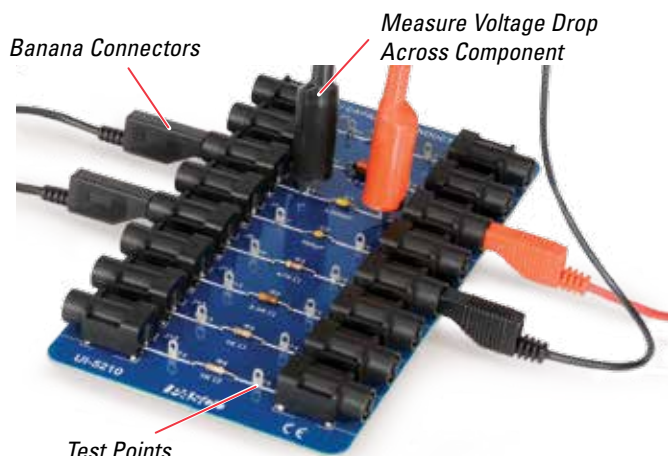

The circuit board accepts patch cords with shrouded banana terminals.

Shown in use with the 850 Universal Interface power amplifier. Both the applied voltage and the resulting current are measured directly by the 850.



### Resistor Capacitor Inductor component board includes

- Two inductors: 6.8 mH; 2.5 mH
- Two capacitors: 3900 pF, 560 pF
- Four resistors: 47 kΩ, 3.3 kΩ, and two 1.0 kΩ.

#### Order Information

Resistor Capacitor Inductor Network..... UI-5210

## RLC Circuit

CI-6512



This board offers a unique set of components for demonstrating:

- ▶ Voltage/Current Phase Relationships
- ▶ RLC Resonance
- ▶ Non-Ohmic Characteristics, components include resistors, capacitors, and an inductor coil.



The 550 or 850 Interface can measure current and voltage as well as provide power to the RLC Circuit.

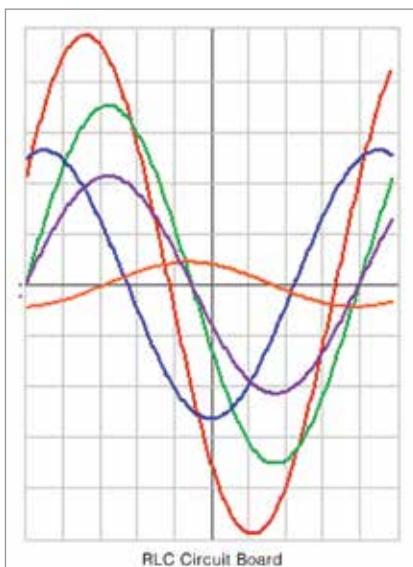

Phase relationships can be studied between voltage across the capacitor, resistor, and inductor.

#### Order Information

RLC Circuit..... CI-6512

# Circuits

## AC/DC Electronics Laboratory

EM-8656

- ▶ Stand-alone operation
- ▶ Computer compatible
- ▶ Includes coil and iron core

The AC/DC Electronics Laboratory dynamically teaches the basics of AC/DC circuits. Students can use this kit with an 850 or 550 or as a stand-alone unit with batteries. The storage tray holds all included components, reducing the chance of losing capacitors, resistors, etc. Two D batteries are required for stand-alone use (not included).

### Experiments

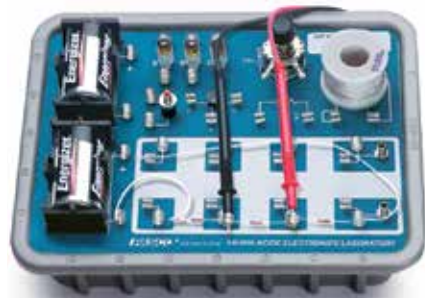

The AC/DC Electronics Laboratory can be used as a stand-alone electricity learning center.

Students study how the resistance of a light bulb filament changes as it heats up. The graph below displays voltage vs. current for an incandescent light bulb. It is clear that the resistance is not linear but changes as the bulb begins to glow.

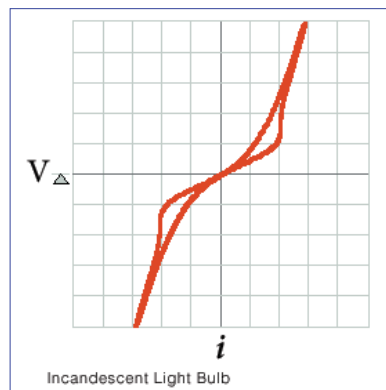

To see the experiments, type the product number into the search box at [www.pasco.com](http://www.pasco.com) and download the manual.

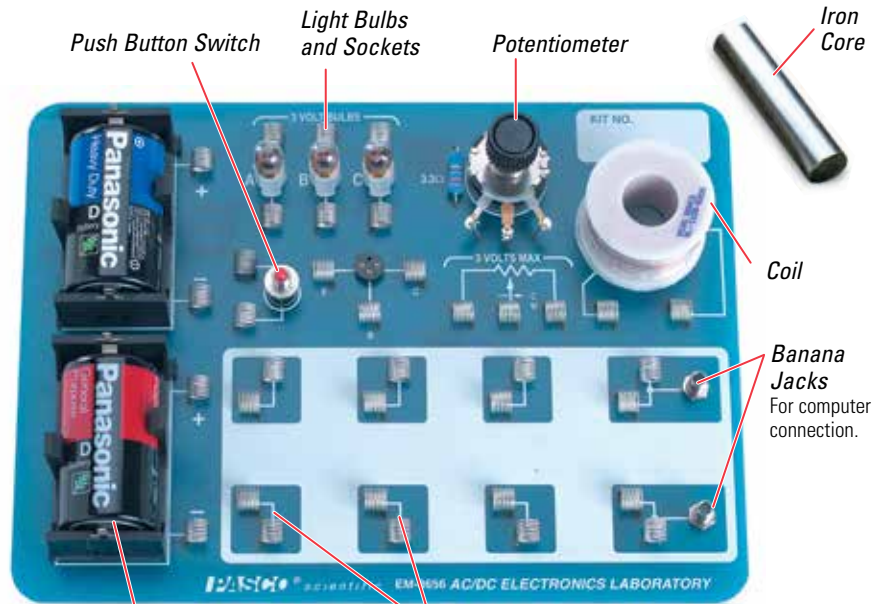

**Battery Holder**

**Component Springs**  
Hold circuit components securely.

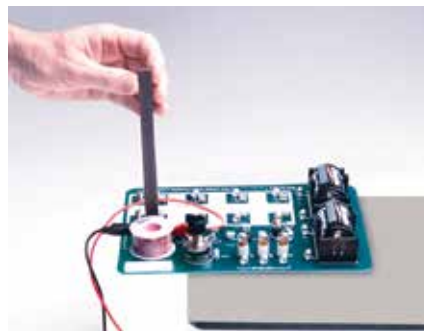

Using PASCO Capstone and a Voltage Sensor, students can measure the electromotive force (EMF) created when a magnet is dropped through a coil. By integrating the voltage-time graph, students can also measure the changes in magnetic flux created by the magnet.

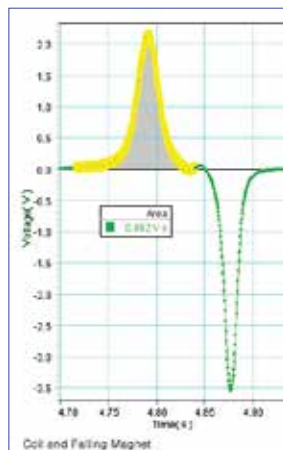

### Includes

- 18 cm x 25 cm circuit board
- Resistors (24) (4.7 Ω–220 kΩ, 5%, 0.25-5 W)
- Capacitors (7) (1 μF–330 μF)
- Diodes (6), Transistors (2), and LEDs (4)
- Wire leads (22 gauge)
- Push-button switch
- Storage tray and laboratory manual
- Battery holders (2)
- Light sockets (3) and lamps (3)
- 25 Ω, 2 W potentiometer (1)
- Component connectors (36)
- Transistor socket (1)
- 8.2 to 19 mH coil and iron core



### Order Information

AC/DC Electronics Laboratory..... EM-8656  
 Electronic Components –  
 AC/DC Electricity..... EM-8668

## Basic Electricity

EM-8622

- ▶ Durable, easy-to-use kits
- ▶ Explore basic electronics
- ▶ Complete lab manual

These simple kits provide a strong foundation for future studies in electronics. They take students from the basics of Ohm's Law through simple series and parallel circuit analysis, and into some elementary aspects of electronics where they will build circuits using capacitors, transistors, and diodes. One kit per two students is recommended, giving each student his or her own circuit board.

### Includes

#### Two Circuit Boards with the following features:

- Battery holders: (2)
- Resistor: (1) 3.3  $\Omega$ , 2 W
- Light sockets: (3) with 3 bulbs (#14)
- Potentiometer: (1) 25  $\Omega$ , 2 W
- Spring connectors: (32)
- Transistor socket: (1)
- Storage tube for holding components (components stay with the kit longer)

#### Components Package containing:

- Resistors: (23) (10  $\Omega$  - 220 k $\Omega$ , 5%, 1/2 W)
- Capacitors: (4) (100  $\mu$ f, 330  $\mu$ f)
- Diodes: (2)
- Transistors: (2)
- Wire leads: 22 gauge



### Typical Experiments

#### With Teacher's Guide and Sample Data.

1. Getting Acquainted
2. Series vs. Parallel Circuits
3. Ohm's Law
4. Resistances in Circuits
5. Voltages in Circuits
6. Currents in Circuits
7. Kirchhoff's Rules (nodes and loops)
8. Capacitors in Circuits
9. Diodes
10. Transistors



To see the experiments, type the product number into the search box at [www.pasco.com](http://www.pasco.com) and download the manual.

### Order Information

Basic Electricity Laboratory  
(2 boards) ..... EM-8622

#### Required:

"D" Cell Batteries

Basic Digital  
Multimeters (2) ..... SE-9786A p. 241

#### Replacement Supplies:

Light Bulbs (#14, 25 pack)..... EM-8627

Electronic Components –

Basic Electricity Lab..... EM-8663

### Components Set



### Unique Spring Connectors

Twist them, bend them, push on them: no damage done. These connectors will still hold components and wires securely.

### Circuit Experiment Board

With this board and the included components, students can build a variety of basic circuits, from resistors in series and parallel to a simple amplifier.

### Low Voltage

Two D batteries provide all the power needed (batteries not included).

## Innovative physics textbooks and PASCO physics products

*Matter & Interactions* is a two-volume textbook and curriculum by Ruth Chabay and Bruce Sherwood, published by Wiley & Sons. It is intended for science and engineering students taking calculus-based introductory university physics. For more information on purchasing these textbooks, visit [www.wiley.com](http://www.wiley.com).

## Electric and Magnetic Interactions

*Electric and Magnetic Interactions (Vol. 2 of 2)* continues the emphasis on atomic-level descriptions and analysis and modeling physical systems. Electrostatics and circuit phenomena are treated as one integrated subject. The Desktop Electricity Kit allows students to carry out just-in-time desktop experiments on electrostatics, magnetism, and circuits.



## Desktop Electricity Kit EM-8675



When used in tandem with the *Electric and Magnetic Interactions* textbook, this kit gives students the conceptual tools to further their understanding of electric and magnetic interactions. While its components look simple, they provide hands-on opportunities for students to build powerful conceptual models.

### Desktop experiment kit includes

- Capacitor 1F, 2.5 V
- Resistor 47  $\Omega$ , 0.5 W
- Resistor 100  $\Omega$ , 0.5 W
- Lamp Holder T3-1/4 (qty 2)
- #48 Miniature Lamp 2.0 V, 0.6 A (qty 2)
- Incandescent Lamp 2.5 V, 0.3 A (qty 2)
- Battery Holder
- Alkaline Battery D-cell (qty 2)
- Bar Magnet (0.375" x 1")
- Compass, Liquid Filled
- Wire-Red 22AWG (6 ft)
- Alligator Clip Leads (12") (qty 7)
- Nichrome Wire #26 (18")
- Nichrome Wire #30 (18")

### Order Information

Desktop Electricity Kit..... EM-8675

# Circuits

## CASTLE "2005" Curriculum

Capacitor-aided system for teaching and learning electricity

- ▶ Complete electricity curriculum
- ▶ Redesigned sections to facilitate beginning CASTLE curriculum in grade 8 or 9

## CASTLE Kit

(for 2 students) EM-8624A

## Economy CASTLE Kit

(for 8 students) EM-8654

## The CASTLE™ Approach

CASTLE is a high school electricity curriculum that leads students from initial naive ideas to an increasingly expert understanding of electrical phenomena. A sequence of self-guided experiments uses large capacitors and transient bulb lighting to help students confront misconceptions, grasp the physics of current propulsion, and build intuitive explanatory models.



### Typical Experiments

#### Core Curriculum investigates

1. What is happening in the wires?
2. What do the bulbs do to moving charge?
3. Where does the moving charge originate?
4. What makes charge move in a circuit?
5. How do wires distribute electric pressure in a circuit?
6. How are values of circuit variables measured?

#### Advanced Curriculum investigates

7. Does all matter contain charge? What are electrons?
8. What is the cause of distant action effects?
9. What pushes on tiny charge carriers like electrons?
10. How do semiconductors work? What is AC?
11. How do motors and generators work?
12. How are magnetic and electromagnetic fields produced?



To see the experiments, type the product number into the search box at [www.pasco.com](http://www.pasco.com) and download the manual.

### The Curriculum Guide

Download the Manuals FREE.

Download the CASTLE Curriculum Guide for FREE. At [www.pasco.com](http://www.pasco.com) just type CASTLE in the search box and click GO!

The teacher's manual helps teachers put the CASTLE Kits to the best possible use. The student manual has investigations for each stated experiment, plus commentaries to prepare students for labs as well as summary exercises to reinforce the lab experience.

### Carbon Resistors

These impede flow similar to low resistance bulbs, but don't glow and divert attention to role as energy sinks.

### Battery Holder

Securely holds batteries and yet makes them visible so their function within the circuit is evident.

### High-Quality Compass

Non-invasive monitoring of movement in wires enables students to visualize the direction of charge flow.

### Miniature Light Bulbs

Different shaped bulbs have different resistance values.

### Screw Sockets and Stands

Stands provide a sturdy support for bulbs and are easy to quickly connect into a circuit.

### 25,000 µF Capacitor

Provides the foundation for this intuitive introduction to current electricity.

### Auxiliary Equipment for Core Curriculum



The Mini Generator (1) enables students to distinguish charge circulation from energy transfer. The 100,000 µF Capacitor (2) lengthens the time scale of transient bulb lighting.

### The Kits

Each CASTLE Kit includes all the materials needed (except for three D batteries) for two students to work through a complete introduction to basic electricity. Each Economy CASTLE Kit includes all the materials needed (except batteries) for eight students.

### Materials Included in Each Kit

Component	CASTLE Kit	Economy Kit
25,000 µF capacitor (20 volts, nonpolar)	1	4
#14 light bulbs (round)	4	25
#48 light bulbs (oblong)	6	25
10 Ohm resistor	4	16
Miniature light bulb sockets and stands	4	16
Wires with alligator clips	10	40
Battery holder (spring-loaded)	1	4
High-quality compass	1	4
Storage box	1	0

### Auxiliary Equipment for Advanced Curriculum



Bi-color LEDs detect electric vectors in electromagnetic fields produced in these coils (3) by accelerating charge when current is turned on and turned off.

### Order Information

- CASTLE Kit ..... EM-8624A  
 Three "D" batteries are required per kit, (not included).  
 Economy CASTLE Kit..... EM-8654  
 12 "D" batteries are required per kit, (not included).

#### Recommended:

- Mini Generator ..... SE-8645 p. 224  
 Capacitor (0.1 F) ..... EM-8655  
 (Minimum of two each per class)  
 Primary and Secondary Coils ... SE-8653A p. 226  
 (Minimum of two each per advanced class)

#### Replacement Supplies:

- We recommend the purchase of one EM-8627 and one EM-8628 spare bulb set for every five CASTLE Kits, or for every Economy CASTLE Kit.  
 Light Bulbs (#14, 25 pack) ..... EM-8627  
 Light Bulbs (#48, 25 pack) ..... EM-8628  
 Light Bulb Sockets (10 pack) .... EM-8630  
 Liquid-Filled Compasses (5 pack) ..... EM-8631A  
 Capacitors (0.025 F, 2 pack) ..... EM-8632

## Resistance Apparatus

EM-8812

- ▶ Slide-wire potentiometer
- ▶ Measure resistance and resistivity
- ▶ Four wire diameters, five wire materials

A current is established in a wire of known diameter, and the voltage drop across a section of the wire is measured. Students can calculate the resistance of the wire and the resistivity of the material.

$$R = \frac{\rho L}{A}$$

### Features

- ▶ **Vary wire length:** Slide-wire potentiometer pick-up makes it easy. Use the built-in scale to measure the length of the wire.
- ▶ **Vary wire diameter:** Four different diameters of brass wire are included. Investigate the difference between resistance and resistivity. Interchange wires quickly and easily.
- ▶ **Vary wire material:** Five different material wires are included. Investigate how resistivity depends on the wire material.
- ▶ **Storage:** Built-in storage tray holds wires.

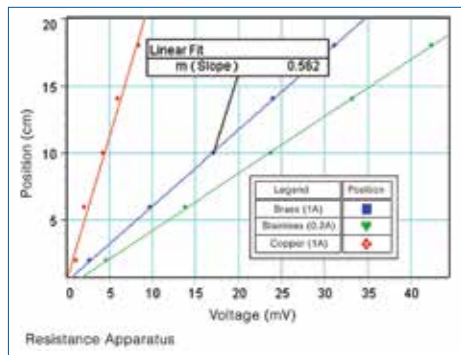

Graph shows voltage drop across various lengths for three different material wires. The slope of the line (along with wire diameter and current) is used to calculate the resistivity of the material.

### Includes

- Two each of the following
- (30 cm long) wires:
    - Copper (1.0 mm diameter)
    - Aluminum (1.0 mm diameter)
    - Stainless Steel (1.0 mm diameter)
    - Nichrome (1.0 mm diameter)
    - Brass (0.5 mm, 0.8 mm, 1.0 mm, 1.3 mm diameter)



**Built-in cm scale and slide wire probe** make it easy to measure the voltage drop across various wire lengths.

**Slide wire probe** Spring-loaded wire probe slides easily along the wire, making contact at a single point.

**Sample wire** Wires are held securely and straight by the wire guides and lugs.

**Connection to DC power supply**

The Resistance Apparatus has a slide wire probe to easily change the measured length of the wire, and utilizes a four wire hook-up to accurately measure the voltage drop. It comes with four different brass wire diameters and four other wire materials.

**Connection to voltmeter**

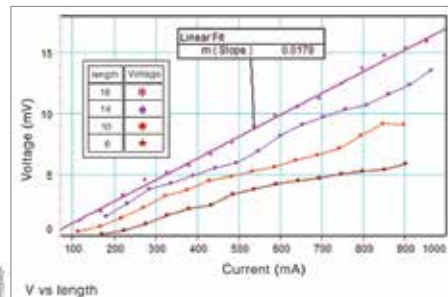

For this experiment, the 850 Universal Interface produces a 10 sec voltage ramp to apply a varying current through a brass wire. A graph of voltage drop vs. current is created, and the slope of this line is the resistance of that length of wire.

### Order Information

Resistance Apparatus.....	EM-8812	
<i>Shown in use with:</i>		
850 Universal Interface.....	UI-5000	p. 12
Voltage Sensor.....	UI-5100	p. 51
2 m Patch Cord Set.....	SE-9415A	p. 216
<i>Recommended:</i>		
Galvanometer Sensor.....	PS-2160	p. 54
Replacement Wires.....	EM-8813	

## Patch Cords

**Banana plug cord sets** 30 cm, 75 cm, and 2 m lengths

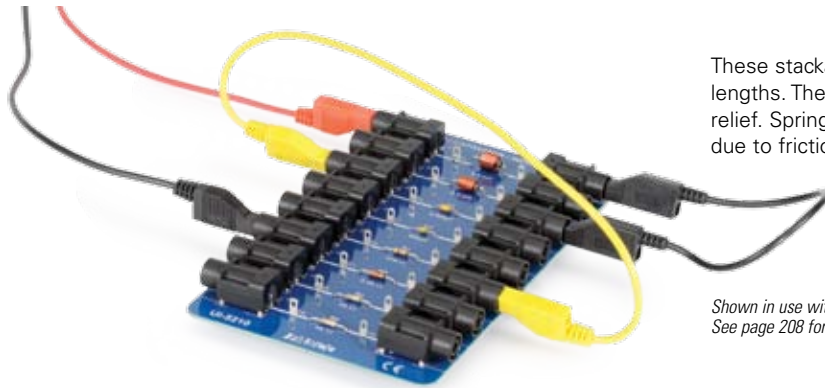

These stackable patch cords come in four convenient lengths. The grips are made of soft plastic for flexible strain relief. Spring connectors rotate in the grips, reducing wear due to friction.

*Shown in use with UI-5210 circuit board.  
See page 208 for more information.*

### 2 Meter Patch Cord Set

SE-9415A

Two each of black and red. 2 m long.



#### Order Information

2 Meter Patch Cord Set.....SE-9415A

### Short Patch Cords

SE-7123

30 cm long, two each red, yellow, blue, black.



#### Order Information

Short Patch Cords (set of 8).....SE-7123

### Alligator Clip Leads

EM-8634 (10 pack)

Use these 30 cm long Alligator Clip Leads for almost any application — from hooking up instruments to bread boarding circuits. They come in sets of 10: two each of yellow, white, red, green and black.



#### Order Information

Alligator Clip Leads (set of 10).....EM-8634

### Long Patch Cords

SE-9750, SE-9751

75 cm long, available in red or black.



#### Order Information

Red (set of 5).....SE-9750

Black (set of 5).....SE-9751

### Shrouded Long Patch Cords

EM-9740, EM-9745

75 cm long, five black or five red. Terminals are shrouded banana plugs. Maximum rating: 600 VDC, 10 Amps.

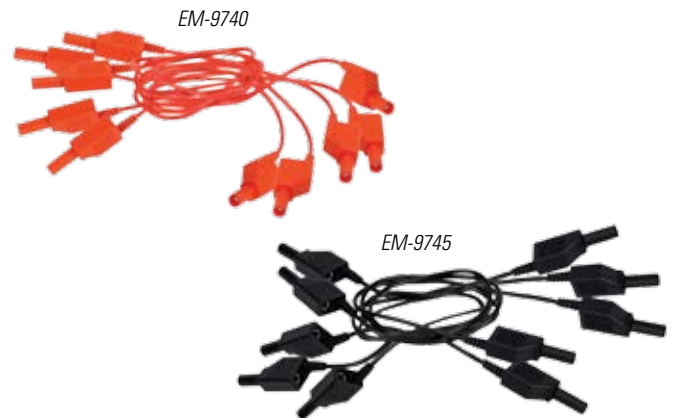

#### Order Information

Red (set of 5).....EM-9740

Black (set of 5).....EM-9745

## Alligator Clip Adapters

SE-9756 (10 pack)

Convert banana plugs into alligator clips with this set of 10 adapters. The 4 mm banana plug clips are bright tin-plated steel.

Includes five red and five black.



### Order Information

Alligator Clip Adapters  
(set of 10).....SE-9756

## Shrouded Alligator Clip Adapters

SE-9758  
(10 pack)

For use with both regular and shrouded banana plugs.

Includes five red and five black adapters.



### Order Information

Shrouded Alligator Clip Adapters  
(set of 10).....SE-9758

## Shrouded Alligator Test Leads

PS-3544  
(Set of 2)

These test leads are included with the Wireless Voltage Sensor (PS-3211). They can also be used with the Wireless Current Sensor (PS-3212).

Includes one red and one black lead.



### Order Information

Shrouded Alligator Test Leads  
(set of 2).....PS-3544

## Resistors and Capacitors

Resistor Pack (10 ea.) EM-8784

10 Ω, 100 Ω, 330 Ω, 560 Ω,  
1000 Ω, 3300 Ω, 10 kΩ, 22 kΩ,  
100 kΩ, 220 kΩ, 330 kΩ.

Resistors

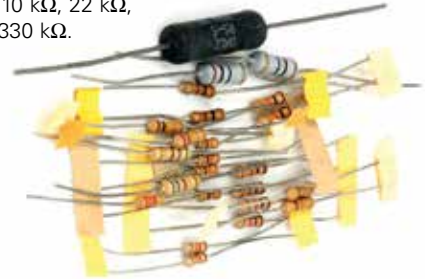

Capacitor Pack (10 ea.) EM-8785

1 μF, 10 μF, 47 μF, 100 μF,  
330 μF, 470 μF

Capacitors

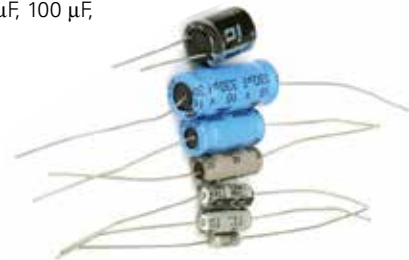

### Order Information

Resistor Pack.....EM-8784  
Capacitor Pack.....EM-8785

## Capacitors

EM-8655 (0.1 F)

EM-8632 (0.025 F)

SE-8626 (1.0 F)



EM-8655:

(0.1 F) Electrolytic, bipolar, 10 Volt capacitor with screw terminals, 4.5 cm diameter, 14 cm long.

EM-8632:

(0.025 F) Electrolytic, bipolar, 25 Volt capacitor with screw terminals, 5 cm diameter, 8 cm long. Contains two capacitors.

SE-8626:

(1.0 F) Electrolytic, bipolar, 5 Volt capacitor.

### Order Information

Capacitors 0.1 F.....EM-8655  
0.025 F (2 pack) .....EM-8632  
1.0 F.....SE-8626

## Basic Circuits

### Circuit Components

Use these stand-alone components to build your own circuits.

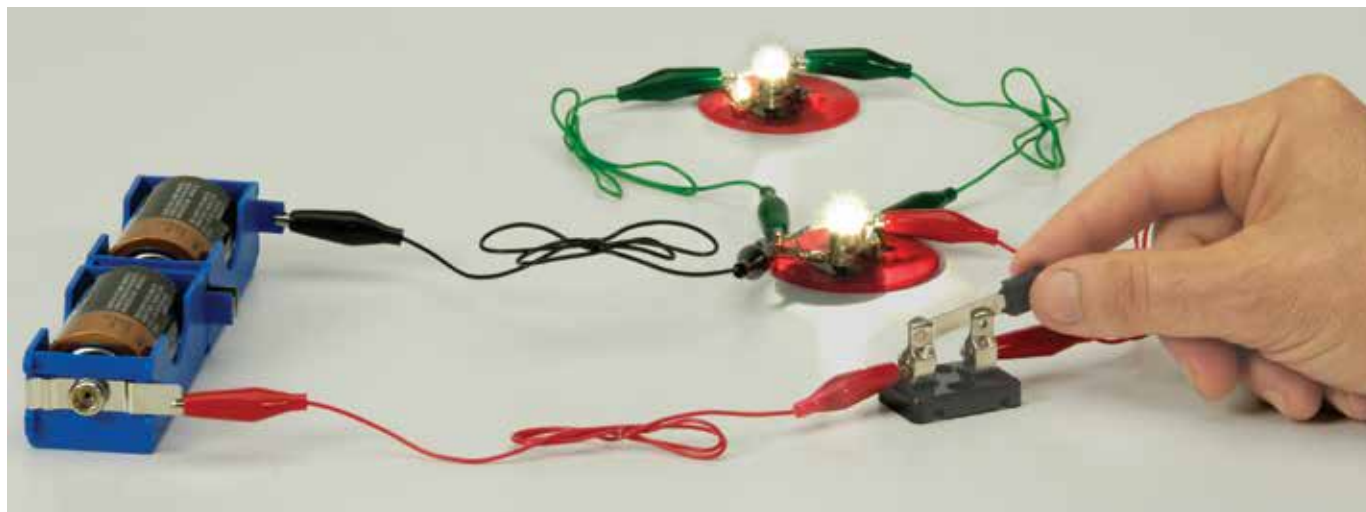

Investigate series and parallel combinations of bulbs and batteries using components detailed below.

#### Series/Parallel Battery Holder

SE-8799 (10 pack)

This unique battery holder allows "D" cell batteries to be easily connected in both series and parallel. Metal extensions on both sides of the holder are also convenient for use with alligator clips.

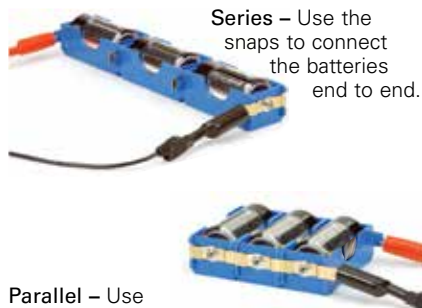

**Series** – Use the snaps to connect the batteries end to end.

**Parallel** – Use the metal slides to use the batteries side by side.

#### Order Information

Series/Parallel Battery Holder (10 pack).....SE-8799

*Recommended:*

Light Bulbs (#14, 25 pack).....EM-8627

Light Bulb Sockets (10 pack).....EM-8630

Alligator Clip Leads (set of 10).....EM-8634

#### Light Bulb Sockets

EM-8630

Miniature socket has a plastic base with spring-loaded metal clips to hold wire leads. Accepts screw-type miniature bulbs. Includes ten sockets.



#### Order Information

Light Sockets (10 pack).....EM-8630

#### Light Bulbs

EM-8627: 2.5 V, 0.3 A bulbs (25 bulbs.)

EM-8628: 2.0 V, 0.06 A bulbs. (25 bulbs.)

EM-8814: 7.5 V, 0.22 A bulbs. (25 bulbs.)

Screw-type base, suitable for use with EM-8630 Sockets.



#### Order Information

2.5 V, 0.3 A (25 pack #14).....EM-8627

2.0 V, 0.6 A (25 pack #48).....EM-8628

7.5 V, 0.22 A (25 pack #50).....EM-8814

#### Switch Set

EM-8815 (6 pack)

This single-pole single-throwknife switch has screw terminals and a Bakelite™ base. Through-holes allow for mounting base to another surface.



#### Order Information

Switch Set (SPST) 6 pack.....EM-8815

#### Alligator Clip Leads

EM-8634 (10 pack)

Use these 30 cm long Alligator Clip Leads for almost any application — from hooking up instruments to bread boarding circuits. They come in sets of 10: two each of yellow, white, red, green and black.



#### Order Information

Alligator Clip Leads (set of 10).....EM-8634

## Fuel Cell Tutorial Set

SE-8837A

This complete fuel cell tutorial kit includes everything needed to study the operation of fuel cells. Students cover the metal base-plate with templates from the tutorial book. These act as guides to which students attach the magnetically mounted components.

Solar cells, fuel cells, gas storage tanks, and a fan can be combined for numerous experiments such as solar car, hydrogen production in a solar hydrogen gas station, air-breathing fuel cell car, solar hydrogen system, and reversible fuel cell system. A detailed textbook, *Fuel Cell Technology for Classroom Instruction* with exercises is included.



### Specifications

#### Electrolyzer Cell 5:

5 cm<sup>3</sup>/min H<sub>2</sub>;  
2.5 cm<sup>3</sup>/min O<sub>2</sub>;  
1.16 W

#### Reversible Fuel Cell H<sub>2</sub>/O<sub>2</sub>/Air

**H<sub>2</sub>/O<sub>2</sub> mode:** 500 mW

**H<sub>2</sub>/Air mode:** 150 mW

**Gas storage:** 30 cm<sup>3</sup> H<sub>2</sub>; 30 cm<sup>3</sup> O<sub>2</sub>

**Solar Module:** 2.0 V / 600 mA; 13 cm x 9 cm

**Load (fan):** 10 mW

**Load (car):** 150 mW

**Cable Length:** 250 mm

**H x W x D:** 140 x 450 x 380 mm

**Weight:** 3.5 kg



### Fuel Cell Tutorial Set Includes

- Reversible Fuel Cell H<sub>2</sub>/O<sub>2</sub>/Air: for production of hydrogen and oxygen and conversion of hydrogen to electricity
- PEM Electrolyzer Cell 5: for hydrogen and oxygen production
- Two Hydrogen/Oxygen Storage Tanks
- Solar Cell
- Fan: to use as an electrical load
- Car: to use as an electrical load
- Experimentation Plate with Templates
- Connector Cables and Tubing
- 250 ml Distilled Water
- Fuel Cell Technology Textbook
- Carrying Case



**Template:** This template for the Solar Hydrogen Setup shows students how to connect the components. The components mount magnetically to the steel backing plate.



**Solar Hydrogen Car Setup:** The car can also be powered directly by the solar cell outside in full sunlight.



**Solar Hydrogen Setup:** Uses solar energy to power the electrolyzer that separates the hydrogen from the oxygen in the water. Then the hydrogen and oxygen are used in the fuel cell to run electricity through the fan.



**Hydrogen Gas Station and Fuel Cell Car H<sub>2</sub>/Air Setup:** Students can construct this hydrogen gas station to fill the tanks on the fuel cell car.

### Order Information

Fuel Cell Tutorial Set..... SE-8837A  
Power solar cell with sunlight or lamp.

# Generators

## Energy Transfer Generator

ET-8771B

- ▶ Transfers gravitational potential energy to electrical energy
- ▶ Open design: 19 mm neodymium magnet can be seen spinning between the two coils
- ▶ Real-time computer measurement of output power

PASCO's Energy Transfer Generator demonstrates the conversion of gravitational potential energy into electrical energy as a falling weight turns a magnet between two coils. The open design permits easy identification of the essential parts of the generator. The supplied lamp or load resistor can be plugged into the output banana jacks. A Voltage/Current Sensor can be used to measure the generated current, voltage, and power.

By wrapping the string around different-sized steps on the three-step pulley, the generator will spin at different speeds. The smaller the pulley radius, the slower the weight falls and the greater percentage of the potential energy is converted to electrical energy.

The AC power generated by spinning the shaft by hand easily lights the included red-green LED. The LED goes from red to green, indicating the direction of the current.

The built-in rod clamp is used to mount the generator on a rod stand.

**Case Dimensions:** 8.7 x 4.4 x 3.6 cm



### Includes

- Generator with three-step pulley
- Red-Green LED mounted on plug
- 100-ohm load resistor mounted on plug
- Spool of thread

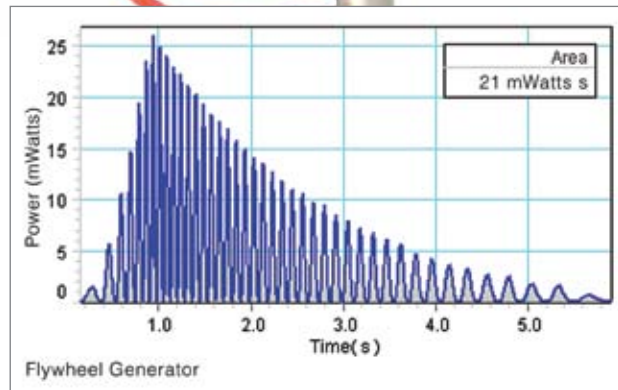
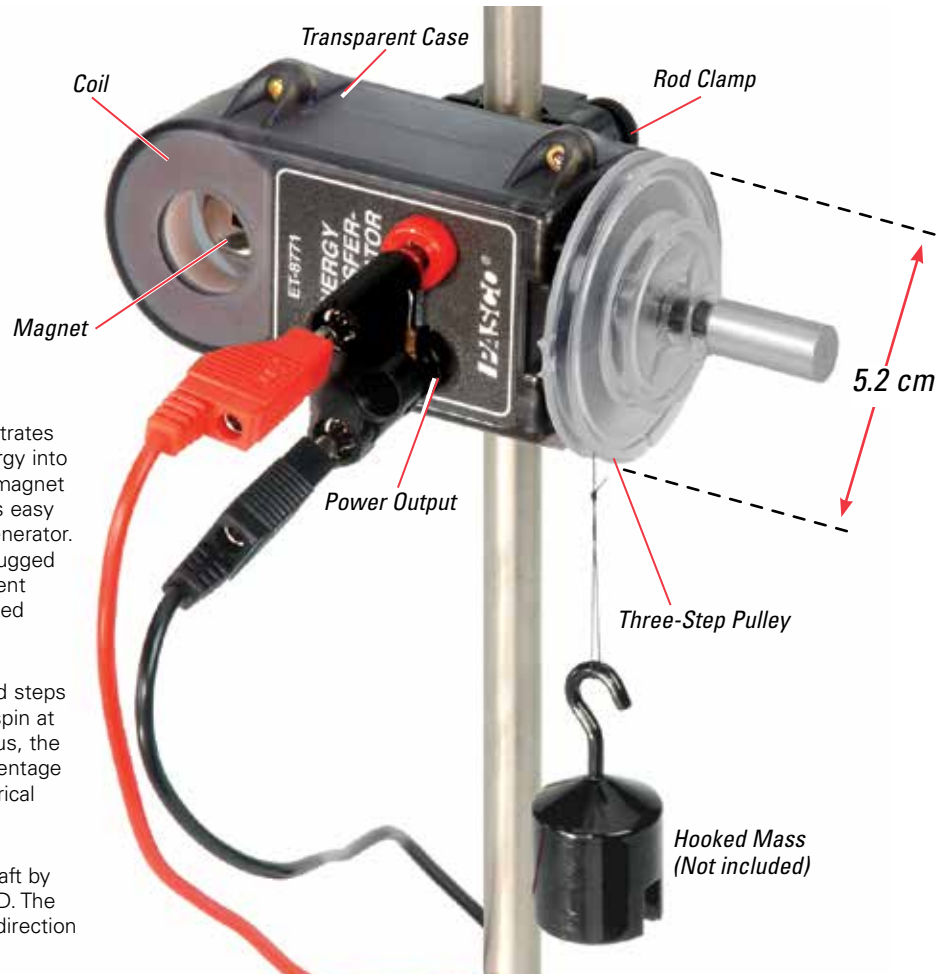

### Order Information

Energy Transfer Generator.....	ET-8771B	
<i>Recommended:</i>		
2 Meter Patch Cord Set.....	SE-9415A	p. 216
Hydro Accessory .....	ET-8772	p. 221
Hooked Mass Set.....	SE-8759	p. 187
Large Rod Base.....	ME-8735	p. 176
Steel Rod (90 cm).....	ME-8738	p. 176
No Bounce Pad.....	SE-7347	p. 184
<i>Required for use with PASPORT:</i>		
Voltage/Current Sensor .....	PS-2115	p. 53

## Energy Transfer Hydro Accessory

ET-8772

- ▶ Demonstrates hydroelectric power generation
- ▶ Open design gives view of spinning turbine and water stream
- ▶ Falling water lights an LED

The Hydro Accessory is used with the Energy Transfer Generator to demonstrate how falling water generates electricity. The gravitational potential energy of the water is converted into electrical energy as the falling water turns the turbine. The water can be supplied using the optional Water Reservoir. The water that has passed through the turbine is caught in a beaker and measured to determine the total mass that has fallen.

The water nozzle size and angle can be adjusted to optimize performance. By changing the height of the Water Reservoir, different efficiencies are achieved.

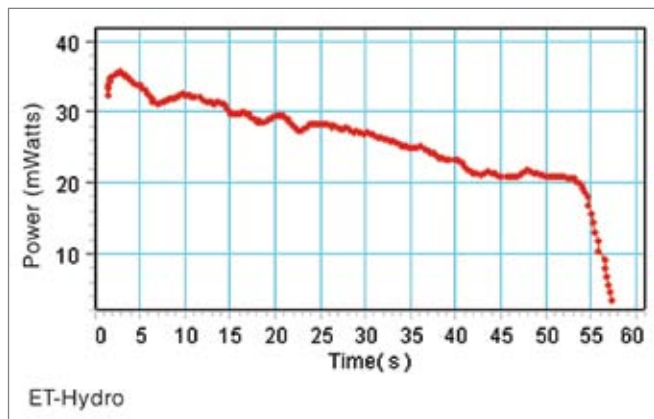

Power data as water falls from the reservoir through the turbine



### Includes

- Turbine housing
- Plastic turbine (4 cm diameter)
- Water nozzles (5)
- Tubing (2 m long)
- Plastic hose clamp
- Screwdriver for attaching Hydro Accessory to Generator

### Order Information

Energy Transfer Hydro Accessory.....	ET-8772	
<i>Required:</i>		
Energy Transfer Generator.....	ET-8771B	
<i>Recommended:</i>		
Water Reservoir.....	ME-8594	p. 185
Large Rod Base.....	ME-8735	p. 176
Steel Rod (90 cm).....	ME-8738	p. 176
Three-Finger Clamp.....	SE-9445	p. 178
1000 ml Beaker (6 pack).....	SE-7288	p. 185

# Wind Turbine & Generator

## Energy Transfer Wind Turbine

ET-8783



Attach this clear propeller to the Energy Transfer Generator for a complete wind energy turbine. Students will better understand the process of electrical energy production from wind after using the turbine.

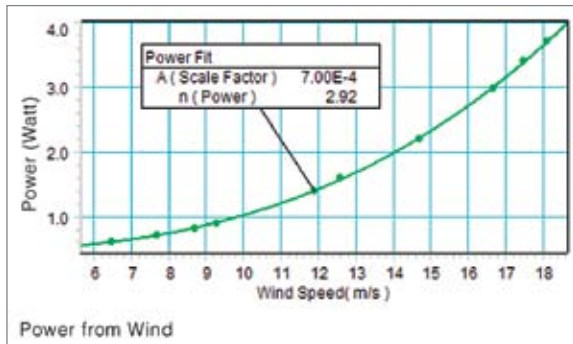

### Includes

- Fan
- Mounting hardware



### Order Information

Energy Transfer Wind Turbine.....ET-8783  
 Required:  
 Energy Transfer Generator.....ET-8771B

## Mini Generator

SE-8645



The Mini Generator produces up to 6 volts DC for basic experiments in electricity, electromagnetism, and electrolysis. It replaces the usual power supply with a device that students can see, operate, and understand.

### Order Information

Mini Generator ..... SE-8645  
 Recommended:  
 Capacitor (1 Farad) (see below)..... SE-8626  
 Light Bulb Sockets (10 pack) ..... EM-8630  
 Light Bulbs #50  
 7.5 V (25 pack) ..... EM-8814

## Capacitor (1 Farad)

SE-8626 (1.0 F)



Electrolytic, bipolar, 5 1.0 F capacitor. Charge up this capacitor with the Mini Generator and then let go of the crank and the handle will continue to rotate in the same direction as the capacitor discharges.

### Order Information

1.0 F Capacitor..... SE-8626

## Ring Launcher

EM-8817

- ▶ Electromagnetic induction
- ▶ Shoots ring 2 meters high
- ▶ Improved design with thermal shutoff

This Ring Launcher has been optimized to maximize safety by enclosing all wiring inside the case. A thermal shutoff switch protects the coil by preventing overheating.

Includes a coil with a bulb that lights by induction when the coil is placed over the launcher core. Also includes five rings: one split aluminum ring that will not launch, one copper ring, one shorter aluminum ring, and two regular length aluminum rings.

### A classic demonstration

In this demo, an aluminum ring is propelled straight up by the Lorentz force that arises from the interaction between the alternating magnetic field of the coil and the current induced in the ring.

For great demo ideas using the PASCO Ring Launcher, check out James Lincoln's AAPT video. James explains how the ring launcher works and walks you through all the classic demonstrations.

<https://www.youtube.com/watch?v=G0sTOcyhcFM>



Ring Launcher design ideas contributed by Carl Schneider & John Ertel from the U.S. Naval Academy.



### EM-8817 includes

- Launcher
- Coil with Light Bulb
- Split Aluminum Ring
- Aluminum Ring (2)
- Short Aluminum Ring
- Copper Ring



Lighting a bulb connected to a coil by induction; coil and bulb are included in Ring Launcher Accessories.

### Order Information

Ring Launcher with Accessories (120 VAC only) .....	EM-8817
<i>Also available:</i>	
Ring Launcher without Accessories .....	EM-8661
<i>Replacement:</i>	
Ring Launcher Accessories .....	EM-8662

# Magnetism

## Magnetic Demonstration System

EM-8644B

### Demonstrate:

- ▶ Magnetic damping
- ▶ Diamagnetism and paramagnetism
- ▶ Magnetic force on a current-carrying wire swing

This all-in-one demonstration system includes the Variable Gap Magnet (EM-8618) and the Magnetic Force Accessory (EM-8642A), both found on the opposite page.



### Includes

- Variable Gap Magnet
- Pole Pieces
- Three aluminum paddles (solid, slotted, closed slotted)
- Glass rod
- Aluminum rod
- Wire swing
- Special mounting rod



### Demonstrate Magnetic Damping

Swing the solid aluminum paddle through the gap and it stops dead, the motion damped due to eddy currents. Now try the slotted paddles. One swings freely while the other is immediately damped.



### Demonstrate Force on a Current-Carrying Wire

Pass a current through the wire swing (power supply not included) to investigate the right-hand rule for magnetic forces.

### Demonstrate Diamagnetism and Paramagnetism

The diamagnetic glass rod (figure a) aligns transverse to the field; the paramagnetic aluminum rod (figure b) aligns with the field.

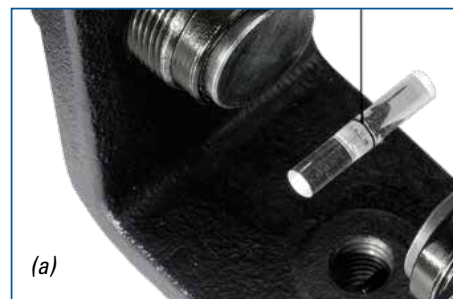

(a)



(b)

### Order Information

Magnetic Demonstration System ..... EM-8644B  
(Includes EM-8618 and EM-8642A)

#### Required:

Power Supply (18 V DC, 5A) ..... SE-9720A p. 232  
or  
Mini-Generator ..... SE-8645 p. 224  
Base and Support Rod ..... ME-9355 p. 177

#### Shown in use with:

2 Meter Patch Cord Set ..... SE-9415A p. 216

## Variable Gap Magnet

EM-8618

- ▶ Lower cost
- ▶ Larger magnets (1 inch diameter)
- ▶ Greater field (1 Tesla maximum)
- ▶ Great for induction experiments

The redesigned Variable Gap Magnet is rugged and durable while providing excellent results as a demonstration tool. The two one inch (2.54 cm) diameter neodymium magnets are mounted on a heavy-duty cast iron base that has a threaded hole for mounting on a support rod to provide even more versatility.

The gap may be varied from 0.5 cm to 8.9 cm using the adjustment screws. Two flat pole pieces are also included to provide a uniform magnetic field when needed.

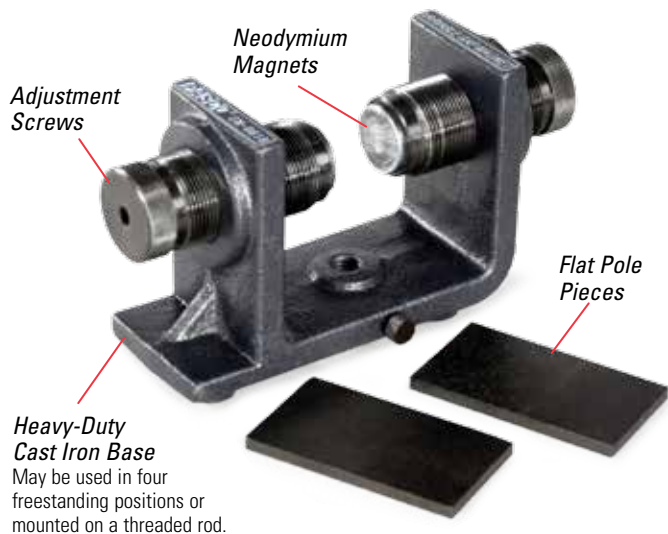

**Heavy-Duty Cast Iron Base**  
May be used in four freestanding positions or mounted on a threaded rod.

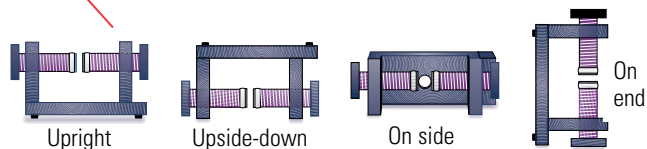

### Order Information

Variable Gap Magnet..... EM-8618  
(Includes Variable Gap Magnet with Pole Pieces)

## Magnetic Force Accessory

EM-8642A

### Includes

- Three aluminum paddles (solid, slotted, closed slotted)
- Glass rod
- Aluminum rod
- Wire swing
- Special mounting rod



### Order Information

Magnetic Force Accessory.....EM-8642A

## Induction Wand

EM-8099

The Induction Wand is a rigid pendulum with a coil at the bottom end, connected to the banana terminals at the other end. A through-hole allows the pendulum to be connected to a Rotary Motion Sensor, for detailed investigations of induction as the coil is swung through a magnetic field.

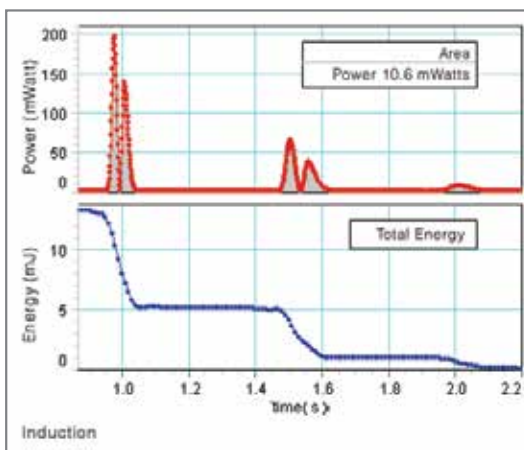

The energy of the pendulum decreases with each pass of the coil through the magnet. The energy dissipated in the resistor is obtained from the area under a power versus time plot.

### Includes

- Wand with screw
- Resistive load



### Order Information

Induction Wand.....EM-8099

## Coils

### Coils and Cores

#### Basic Coil Set

SF-8616

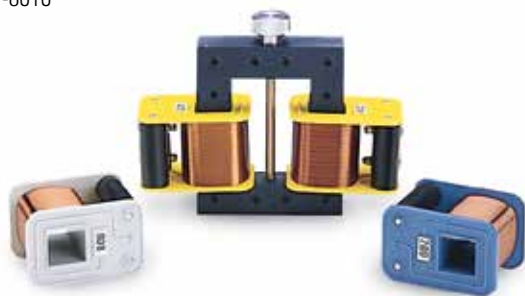

These high-quality coils and laminated iron cores provide an effective introduction to electromagnetic theory. Purchase them individually or as a complete set. The coils are color-coded and each coil is labeled with the number of turns and the direction of the winding. Use them to investigate:

**Electromagnetism:** Show how the magnetic field can be increased by increasing the current, by adding an iron core, or by using a coil with more turns.

**Induction:** Pass a magnet through a coil and detect the resulting electromotive force (EMF) with a galvanometer. Show how the EMF depends on the number of turns in the coil and on the relative velocity of the magnet and coil.

**Transformers:** Mount coils onto the U- or E-shaped iron cores to demonstrate mutual inductance and transformer theory. Then connect a load to investigate power transfer. Investigate basic transformer theory with an AC power supply and a voltmeter. Advanced principles require a high power output function generator (Model PI-9587C or PI-9598) and an oscilloscope. For better experiments and demonstrations, use a computer with PASCO's 850 Universal Interface (p. 11).

#### Primary and Secondary Coils

SE-8653A



Transformer theory can be studied with this set of nested coils consisting of an outside coil (length = 11 cm) having 2920 turns, an inner coil (length = 12 cm) having 235 turns, and a removable 0.96 cm diameter soft iron core. The outer coil is large enough (inner diameter = 2 cm) to drop a bar magnet (SE-8604, page 236) through to demonstrate induction.

#### Order Information

Primary and Secondary Coils ..... SE-8653A

#### Complete Coil Set

SF-8617



Using the signal generator capability of the 850 Universal Interface and oscilloscope display of PASCO Capstone™ Software, students can investigate transformer theory.

Basic Coil Set SF-8616	Complete Coil Set SF-8617	Model	Individual Parts Description
1	1	SF-8609	Coil (200 turn)
2	2	SF-8610	Coil (400 turn)
1	1	SF-8611	Coil (800 turn)
-	1	SF-8612	Coil (1600 turn)
-	1	SF-8613	Coil (3200 turn)

#### Order Information

Basic Coil Set ..... SF-8616  
 Complete Coil Set ..... SF-8617  
*Individual parts sold separately (see chart above).*

#### Air Core Solenoid

SE-7585

This air core solenoid has an inner diameter of 5.5 cm and a length of 13.5 cm, allowing ample room to insert an experimental apparatus into its uniform magnetic field. The maximum current of 5 A produces a 200 gauss magnetic field.



#### Specifications

**Total Number of Turns:** 550-570

**Wire Gauge:** 16

**Capacity:** 5 A continuous

**Core Inner Diameter:** 5.5 cm

#### Order Information

Air Core Solenoid ..... SE-7585

## Field and Detector Coils



1. EM-6711 Field Coil: 200 turns of #22 copper wire, 18.6 cm ID, 22.1 cm OD. Max. current 2 A.
2. EM-6723 500 turns of #22 copper wire. Max current 2 A.
3. EM-6712 Detector Coil (400 turn): 400 turns of #28 copper wire.
4. EM-6713 Detector Coil (2000 turn): 2000 turns of #36 copper wire.
5. EM-6714 Bi-color LED Indicator.

### Features

- **Verify Faraday's Law:** Verify all aspects of Faraday's Law.
- **Qualitative Demonstration:** With the Bi-Color LED Indicator and the Variable Gap Magnet, students can see when a current is induced in the detector coil. With the LED indicator plugged into a detector coil, the LED flashes red or green as the detector coil passes through the magnet.
- **Quantitative Demonstration:** PASCO's coils can be used with a function generator and an oscilloscope, or connected to the 850 Universal Interface.

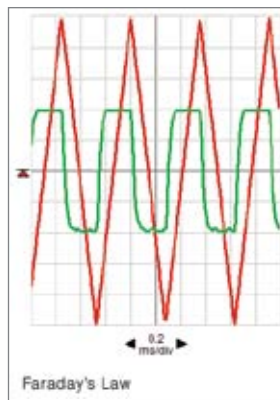

A 5 volt triangle wave (red trace) is applied to the Field Coil, and the induced voltage in the 2000-turn Detector Coil is a square wave (green trace).



Developed for Workshop Physics® activities



For details of experiments using these coils, see Christopher C. Jones, "Faraday's Law Apparatus for the Freshman Laboratory". *Am. J. Phys.* 1987; 55(12):1148-1150.

### Order Information

Field Coil (200-turn).....	EM-6711	
Field Coil (500-turn).....	EM-6723	
Detector Coil (400-turn).....	EM-6712	
Detector Coil (2000-turn).....	EM-6713	
LED Indicator .....	EM-6714	
<i>Recommended:</i>		
Variable Gap Magnet .....	EM-8618	p. 225
850 Universal Interface .....		p. 12
<i>or</i>		
Low Voltage AC/DC Power Supply .....	SF-9584B	p. 235
<i>and:</i>		
Function Generator.....	PI-8127	p. 238

## Helmholtz Coils

EM-6722 with 200-turn Coils  
EM-6724 with 500-turn Coils

The Helmholtz Coils consist of two coils mounted on a base to provide a uniform magnetic field between the coils. The base has a slot that allows the coils to be spaced apart at any distance from 3 cm to 20 cm (center-to-center distance). The proper separation for Helmholtz coils (e.g., the radius of the coils) is marked on the base. Two 0.635 cm (0.25 inch) diameter holes between the coils accommodate mounting devices in the uniform magnetic field.

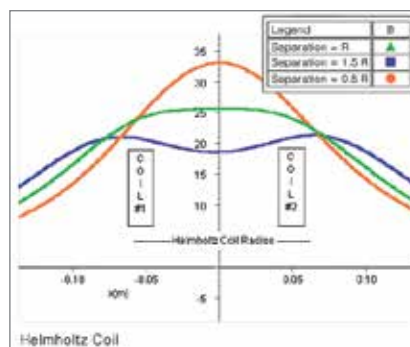

This plot shows the magnetic field strength along the axis of Helmholtz coils for three different coil separations: the green data is the magnetic field with the coils separated at the proper distance (the radius of the coils).

### Order Information

Helmholtz Coils (200-turn Coils) .....	EM-6722
Helmholtz Coils (500-turn Coils) .....	EM-6724
Helmholtz Coil Base (Without Coils) .....	EM-6715

# Force on Current Carrying Wires

## Basic Current Balance

SF-8607

- ▶ Measure force vs. current, wire length, magnetic field, and angle
- ▶ Use a gram balance to measure force

One to six magnets are mounted on an iron yoke, which is placed on a gram balance. A conductor is suspended between the magnets. The weight of the magnets and yoke is measured, then a current (0-5 A) is passed through the conductor. The change in the reading of the balance (0-4 grams) measures the force between the conductor and the magnetic field.

*Basic Current Balance:  
measuring the force on a current-carrying  
wire in a magnetic field.*

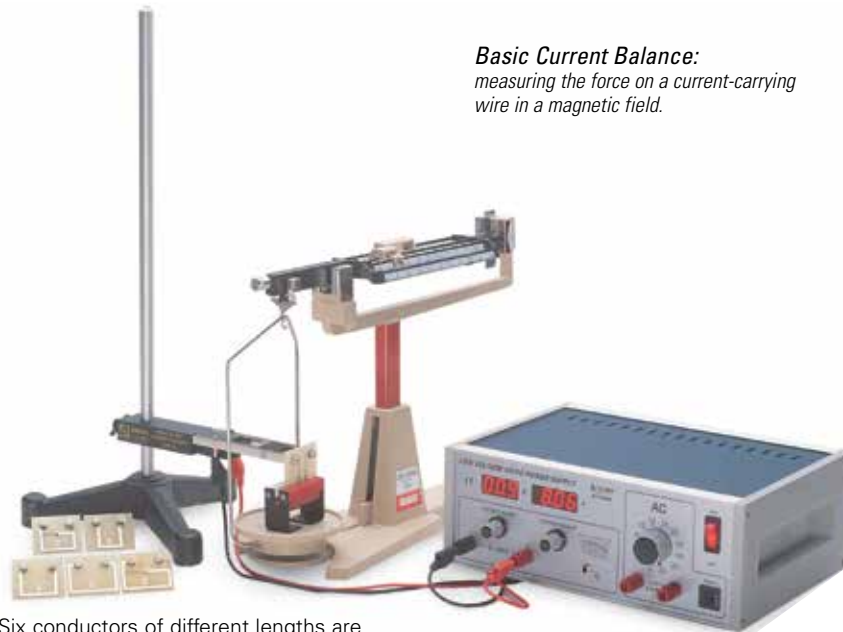

Six conductors of different lengths are provided and can be easily changed while maintaining a repeatable position with respect to the magnetic field.

### Includes

- Iron Yoke (holds magnets)
- Removable Magnets (six)
- Six Conductors (1, 2, 3, 4, 6 and 8 cm in length)
- Mount (for holding/positioning conductors)



## The Current Balance Accessory Kit

SF-8608

The Current Balance Accessory Kit completes the Basic Current Balance, allowing the angle between the conductor and the magnetic field to be varied. The experiment is the same as with the Basic Current Balance, but a 10-turn rectangular coil is used. The coil can be turned through a full 180°, and a built-in degree scale lets students accurately measure the angle between the coil and the field of the fixed magnet.



### Includes

- Fixed Magnet with Yoke
- 10-turn Rectangular Coil

### Order Information

Current Balance  
Accessory Kit ..... SF-8608

### Order Information

Basic Current Balance.....	SF-8607	
<i>Required:</i>		
Ohaus Balance.....	SE-8725	p. 186
Power Supply.....	SF-9584B	p. 235
Base and Support Rod.....	ME-9355	p. 177
<i>Recommended:</i>		
Basic Digital Multimeter.....	SE-9786A	p. 241
Tesla Meter.....	SF-7579	p. 230
<i>Shown in use with:</i>		
2 Meter Patch Cord Set.....	SE-9415A	p. 216

### Lenz's Law Demonstrator

MG-8600



Magnet 6 cm long  
19.8 mm OD



1.5 meter tube

Drop a mass through the 1.5 meter tube. It takes about half a second to drop. Then drop a magnet with an identical mass. It takes over 10 times as long to fall. As the magnet falls, it generates a current in the tube, moving in one direction above the magnet and in the opposite direction below. Both currents obey Lenz's Law and induce magnetic fields that oppose the magnet's motion. Both currents obey Lenz's Law and induce magnetic fields that oppose the magnet's motion. See the difference in weight as the magnet falls through the tube.

#### MG-8600 includes:

- Lenz's Law Magnet
- Unmagnetized Slug
- 1.5 m Aluminum Tube (2 cm ID, 0.28 cm wall)
- 10-turn Rectangular Coil
- Attachment Bracket for Spring Scale
- Ohaus Spring Scale 10N

#### Order Information

Lenz's Law Demonstrator ..... MG-8600

### 3-D Magnetic Field Demonstrator

SE-8603

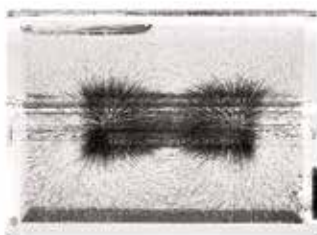

(Magnet not included)

With this 3-D Magnetic Field Demonstrator, the iron filings are suspended in oil in a sealed acrylic container. Insert a magnet into the 10 mm opening, or two magnets with opposing polarities, and watch the filings line up. View the demonstration directly or with an overhead projector.

#### Order Information

3-D Magnetic Field Demonstrator ..... SE-8603

*Recommended:*  
Bar Magnets (set of 2) ..... SE-8604 p. 230

### Dip Needle

SF-8619



This rotatable compass has durable and almost frictionless bearings. Use it horizontally as a standard compass or vertically to find the dip angle of the Earth's magnetic field. Instruction sheet included.

#### Order Information

Dip Needle ..... SF-8619

### Magnaprobe

SE-7390



The Magnaprobe is a great way to demonstrate the 3-D nature of magnetic fields. The probe features a gimbal-mounted Alnico magnet, which is free to move in the x, y, and z dimensions. Suggested activities are included with each probe. Magnaprobe is 12 cm long.



#### Order Information

Magnaprobe (1 each) ..... SE-7390

## Magnetism Supplies

## Plotting Compass

SE-8680



(Appearance may vary)

Includes 20 compasses (19 mm diameter).



## Order Information

Plotting Compass  
(20 pack) ..... SE-8680Liquid Filled Compasses  
(5 pack)

EM-8631A



2.5 cm long needle has north end marked in black. This compass is perfect for investigating the magnetic fields around straight wires. 4.5 cm diameter liquid filled plastic case. Contains five compasses.

## Order Information

Liquid Filled Compasses  
(5 pack) ..... EM-8631A

Replacement part for CASTLE Kits (EM-8624A and EM-8654).

## Neodymium Magnets

Neodymium magnets are some of the strongest commercial magnets available. They come either bare or with a protective coating to prevent the brittle metal from chipping. Plastic case included.

**WARNING**  
This product contains small magnets. Swallowed magnets can stick together across intestines causing serious infections and death. Seek immediate medical attention if magnet(s) are swallowed or inhaled.

Without Hole EM-8648B

13 mm dia. x 5 mm



## Order Information

Neodymium Magnets (16)  
(without hole).....EM-8648B

## Tesla Meter

SF-7579

- ▶ 0–2 Tesla range
- ▶ Range autoscaling



A 6-12 Volt DC power supply is required to use the Tesla Meter.

## Includes

- Tesla Meter with Digital Display
- Probe (80 mm x 8 mm x 2 mm)
- Power Adapter: 110V AC to 9V DC, 200 mA

## Specifications

**Resolution:** 0.1 mT (0 – 200 mT)  
1 mT (200 mT – 2T)**Accuracy:** ±5% of measurement

## Order Information

Tesla Meter ..... SF-7579

## Bar Magnets

SE-8604 (2 pack)

These cylindrical magnets (10 x 50 mm) are small, strong, and color-coded for polarity. Plastic case and keeper plates included.



## Order Information

Bar Magnets  
(2 pack) ..... SE-8604

## Alnico Bar Magnets

EM-8620 (2 pack)



These magnets (150 x 13 mm) are stronger and last longer than iron magnets. They fit a St. Louis motor and the north poles are notched. Case included.

## Order Information

Alnico Bar Magnets  
(2 pack) ..... EM-8620

# DC Programmable Power Supply

PI-9880

- ▶ 1 amp at 18 VDC
- ▶ Digital display
- ▶ Ramp or step positive voltage up or down

Provides a current of 1 A at 18 V, with a resolution of 0.01 V and typical ripple of 10 mV. This DC power supply has added features to cycle the voltage on and off, to ramp the voltage up or down between the maximum and minimum set, and to change the voltage in steps. A positive offset can be introduced so the ramp can start at a voltage other than zero. Minimum period is 0.1 sec (10 Hz) and the maximum period is 999 seconds.

The digital display has four digits (0.76 cm high) and can display voltage, current, or time. The time is displayed to set the period, duration, or duty cycle.

There are both coarse and fine adjustment knobs. As a safety factor, a maximum current and a maximum voltage can be set to protect your students' external circuits. The output is voltage-regulated but not current regulated.

The power supply is connected to AC power using a universal power adapter.

**Power Output**  
Standard banana jacks allow the DC Power Supply to be easily connected to circuits.

**Indentations**  
For stacking during storage.

**LED Display**  
Red LEDs make the display easy to read.

*Small and light weight;  
12 cm x 13 cm x 5.5 cm high  
and approximately 300 g.*

**Display Selection**  
Current, voltage, cycle time.  
Green LED indicates which measurement has been selected.

**Start/Stop**

**Cycle**  
Choice of steps, ramps, or cycle on and off.

**Amplitude Adjustment**  
Sets maximum current, voltage, cycle period.



## Available Functions:

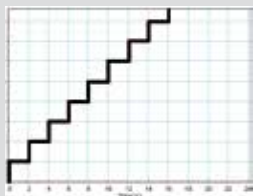

Step Voltage Up

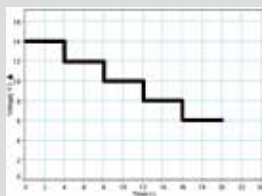

Step Voltage Down from Max to Min

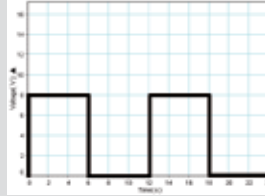

Cycle On and Off

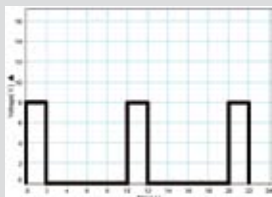

Cycle On and Off with Different Duty Cycles



Ramp Up with Offset

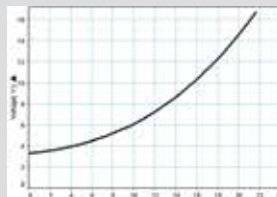

Programmable

## Includes

- DC Power Supply
- Universal Power Adapter



## Order Information

DC Programmable Power Supply ..... PI-9880

## DC Power Supplies

### Power Supply (18 VDC, 5 A)

SE-9720A

- ▶ 0-18 VDC at 0-5 A
- ▶ Serial and parallel operation



This power supply has a remote control connector and switch on the rear panel, so units can be connected in series or parallel with each other to provide higher voltage, higher current, and higher power output.

#### Specifications

**Digital Meters:** Voltage and current; LED

#### Constant Voltage Mode:

- Output Voltage: continuously variable, coarse and fine control
- Line Regulation:  $\leq 0.01\% \pm 3$  mV
- Load Regulation:  $\leq 0.01\% \pm 3$  mV
- Ripple and Noise:  $\leq 0.5$  mV rms

#### Constant Current Mode:

- Output Current: continuously variable, coarse and fine control
- Line Regulation:  $\leq 0.02\% \pm 3$  mA
- Load Regulation:  $\leq 0.02\% \pm 3$  mA
- Ripple and Noise:  $\leq 3$  mA rms

**Power Source:** AC 100, 120, 220, 240 V  $\pm 10\%$ , 50/60 Hz;  
Protection – overload and reverse polarity protected

**Dimensions:** 29 x 13 x 15 cm (5.5 kg)

#### Includes

- Instruction Manual
- Test Lead

#### Order Information

Power Supply (18 Volt DC, 5 A)..... SE-9720A

### Student Power Supply (18 VDC, 3 A)

SE-8828

- ▶ 0-18 VDC at 0-3 A
- ▶ Constant voltage or current
- ▶ Short-circuit protected
- ▶ Current limiting
- ▶ Low noise/ripple



This high quality, compact power supply provides the DC voltage and current levels necessary for most introductory student labs.

#### Specifications

**Digital Meters:** Voltage and current; Backlit LCD

#### Constant Voltage Mode:

- Output Voltage: continuously variable
- Line Regulation:  $< 0.01\% \pm 3$  mV
- Load Regulation:  $< 0.01\% \pm 2$  mV
- Ripple and Noise:  $< 0.5$  mV rms

#### Constant Current Mode:

- Output Current: continuously variable
- Line Regulation:  $< 0.2\% \pm 3$  mA
- Load Regulation:  $< 0.2\% \pm 3$  mA
- Ripple:  $< 3$  mA rms

**Power Source:** AC 100, 120, 220, 240 V  $\pm 10\%$ , 50/60 Hz;  
Protection – overload and reverse polarity protected

**Dimensions:** 34 x 26 x 15 cm (11.5 kg)

#### Order Information

Student Power Supply (18 Volt)..... SE-8828

## Triple Output Power Supply

SE-8587

- ▶ 0-30 VDC at 0-3 A
- ▶ Fixed 5 V and 12 V outputs
- ▶ Digital voltage & current meters
- ▶ Overload and short circuit protection
- ▶ Constant voltage or current



This power supply offers adjustable voltage output (0-30 V), adjustable current output (0-3 A), and two independent constant voltage outputs (5 V and 12 V) with easy snap terminals. Digital displays of both current and voltage allow students to easily gather data. Features overload and short-circuit protection.

### Specifications

**Digital Meters:** Voltage and current; 3 digits; LCD

#### Constant Voltage Mode:

- Output Voltage: continuously variable
- Line Regulation:  $\leq 0.05\% \pm 10$  mV
- Load Regulation:  $\leq 0.05\% + 10$  mV
- Ripple and Noise:  $\leq 0.5$  mV rms

#### Constant Current Mode:

- Output Voltage: continuously variable
- Line Regulation:  $\leq 0.05\% + 10$  mA
- Load Regulation:  $\leq 0.05\% + 10$  mA
- Ripple and Noise:  $\leq 3$  mA rms

**Fixed Output Voltage:** 5 V at 0.5 A continuous; 1 A max.  
12 V at 0.5 A continuous; 1 A max.

**Power Source:** AC 110/220 VAC, 50/60 Hz

**Dimensions:** 29 x 13 x 15 cm (5.5 kg)

### Order Information

Triple Output Power Supply ..... SE-8587

## Power Supply (30 VDC, 6 A)

SE-9721A

- ▶ 0-30 VDC at 0-6 A
- ▶ 0.01% high regulation
- ▶ Constant voltage or current



This single output linear DC power supplies is suitable for high-end precision bench top applications. Low load and line regulation for both constant voltage and constant current mode ensure reliable, predictable output. Overload and reverse polarity protection as well as internal selection for dynamic or constant load are standard.

### Specifications

**Digital Meters:** Voltage and current: 3 1/2 digits; 0.5" LED display

#### Constant Voltage Mode:

- Output Voltage: continuously variable, coarse and fine control
- Line Regulation:  $\leq 0.01\% \pm 5$  mV
- Load Regulation:  $\leq 0.01\% + 5$  mV
- Ripple and Noise:  $\leq 1$  mV rms 5 Hz ~ 1 MHz

#### Constant Current Mode:

- Output Voltage: continuously variable, coarse and fine control
- Line Regulation:  $\leq 0.2\% \pm 3$  mA
- Load Regulation:  $\leq 0.2\% \pm 3$  mA
- Ripple:  $\leq 3$  mA rms

**Power Source:** AC 100, 120, 220, 240 V  
 $\pm 10\%$ , 50/60 Hz; Protection – overload and reverse polarity protected

**Dimensions:** 34 x 26 x 15 cm (11.5 kg)

### Includes

- Instruction Manual
- Test Lead

### Order Information

Power Supply (30 Volt DC, 6 A)..... SE-9721A

# High Voltage Power Supplies

## High Voltage Power Supply

SF-9585A

- ▶ 0 to 50 VDC at up to 50 mA
- ▶ 0 to 500 VDC at up to 50 mA
- ▶ 2 to 7 VAC at up to 3 A



Appearance may vary.

A versatile and reliable supply for experiments requiring medium to high voltages at relatively low currents. The 50 and 500 VDC outputs are independently variable, providing up to 50 mA, and the output displays can be switch-selected to read voltage and current in either range. A separate set of output terminals provides 2, 4, 5, 6 and 7 VAC at up to 3 A, a convenient source for electron tube filaments.

*Note: The positive terminal of the 50-volt supply is internally connected to the negative terminal of the 500-volt supply.*

### Specifications

- Ripple:** Less than 0.1%,  $\pm 1$  digit line  
**Regulation:** <1% at 98-130 V (line voltage)  
**Load Regulation:** <1% at 0-100% load  
**Displays:** Digital readouts 0-50 V, 0-500 V, 0-50 mA (switch-selectable)  
**Power Source:** 115/220 VAC, 50/60 Hz  
**Dimensions:** 21 x 29 x 11 cm (8 x 12 x 4 in.)

### Order Information

High Voltage Power Supply ..... SF-9585A

## Kilovolt Power Supply

SF-9586B

- ▶ 0 to 6 kVDC
- ▶ 6.3 VAC, 2 A filament source
- ▶ Digital readout



Appearance may vary.

This Kilovolt DC Power Supply is used for electron tubes, electrostatics, the Millikan Oil Drop experiment, etc. The high voltage section is by design "floating" relative to ground. This means that either the black (negative) terminal or the red (positive) terminal may be connected to ground to give a voltage range of 0 to +6 kV, resp. 0 to -6 kV relative to ground. The output is well regulated and current limited for safety. (The maximum short circuit current is 2 mA).

### Specifications

- DC – Output Voltage:** 0-6 kV stabilized, continuously adjustable
- Short Circuit Current: 2 mA (Max.)
  - Ripple and Noise (max.): Less than 1%
  - Readout Accuracy: Better than 1% + 1 digit
- AC – Output Voltage:** 6.3 V
- Output Current (max.): 3 A
- Dimensions:** (W x D x H): 312 x 225 x 117 mm

### Order Information

Kilovolt Power Supply ..... SF-9586B

## AC/DC Power Supply 12V 3A

SF-9581

- ▶ Combined DC and AC supply at a low price
- ▶ Stabilized, continuously adjustable DC: 0 to 12 V
- ▶ AC presets: 2, 4, 6 and 12 V
- ▶ Currents up to 3 A for both outputs
- ▶ Outputs are overload protected

*Appearance may vary.*

This power supply delivers a stabilized DC voltage, continuously adjustable between 0 and 12 V. Moreover, an AC voltage is supplied, which can be set to 2, 4, 6 or 12 V. The two outputs can simultaneously supply up to 3 A. Both outputs are overload protected. The DC part is protected electronically and resets automatically, while the AC part is provided with a circuit breaker that must be reset manually if it trips.

### Specifications

**DC Output Voltage:** 0-12 V (stabilized), continuously adjustable

**Maximum DC Output Current:** 3 A

**Maximum Ripple:** 100 mV

**AC Output Voltage:** 2, 4, 6, 12 V, stepwise adjustable

**Maximum AC Output Current:** 3 A

**Power Consumption:** 110 W (Max.)

**Fuse:** T 1A (slow)

**Dimensions:** (WxDxH): 20.3 x 20.5 x 11.7 cm

### Order Information

AC/DC Power Supply..... SF-9581

## Low Voltage AC/DC Power Supply

SF-9584B

- ▶ 0 to 24 VDC at 0 to 10 A
- ▶ 0 to 24 VAC at up to 6 A
- ▶ Digital readouts

*Appearance may vary.*

The low voltage Power Supply has been designed specifically for use in teaching physics, chemistry, and other science subjects. It can provide both direct current (DC) and alternating current (AC). The Power Supply can provide both types of electrical power at the same time, and they can be adjusted independently of one another. Separate digital displays are provided for DC and AC output.

### Specifications

**DC – Output Voltage:** 0 to 24 V DC

- Current: From 0 to 12 V, 10 A maximum. From 12 to 24 V, linearly decreasing from 10 A to 6 A, dependent on voltage setting
- Meter: Digital display (volts/amps); 1%  $\pm$  2 LSD; Ripple: <25 mVpp

**AC – Output Voltage:** 0 to 24 V AC, continuously adjustable

- Current: 0 to 6 A
- Overload Protection Meter: Digital display (volts/amps); 2%  $\pm$  LSD

**Power Source:** AC 115/230 VAC, 50/60 Hz

**Power Use:** 320 W

**Dimensions:** 30 x 23 x 12 cm (12 x 9 x 5 in.)

### Order Information

Low Voltage AC/DC Power Supply ..... SF-9584B

# Power Supplies

## Power Supplies and a Current Amplifier for Advanced Physics Experiments

The power supplies and instruments on this page are used in various advanced physics experiments involving finding fundamental constants (Photoelectric Effect, Franck-Hertz, and e/m). Since each experiment uses some combination of these, it is possible to purchase one of each to perform all three experiments, one at a time.

Experiment	DC Power Supply I	DC Power Supply II	DC (Constant Current) Supply	DC Current Amplifier
Photoelectric Effect (page 288)	X			X
Franck-Hertz (page 289)	X	X		X
e/m (page 287)		X	X	

Connect to a 550 or 850 Interface:

These instruments can be used stand-alone by reading the digital displays. However, they have special data collection ports for connecting a 550 or 850 Universal Interface (see pp. 10-11) to record data and analyze it in PASCO Capstone. Each type of voltage and current reading is automatically identified when the power supply is connected to a 550 or 850 analog port with the special cord (included).

### DC (Constant Voltage) Power Supply I

SE-6615

- ▶ 0 to 6.3 V DC, 1 A maximum
- ▶ -4.5 to 0 V DC, 10 mA maximum
- ▶ -4.5 to 30 V DC, 10 mA maximum

The (0 to 6.3 V) output is independent of the (-4.5 to 0 V) and (-4.5 to 30V) outputs, which share an output and are selected by pushing a button.



#### Specifications

Independent floating ground reference

**Ripple:** <1%

*Includes cords to connect to the 550 and 850.*

#### Order Information

DC (Constant Voltage)  
Power Supply I .....SE-6615

### Tunable DC (Constant Current) Power Supply

SE-9622

- ▶ 0 to 3.5 A DC, 20 V maximum
- ▶ Fixed 6.3 V AC, 1A maximum



This constant current power supply has a digital readout for the current, which can be tuned from 0 to 3.5 A DC. It also has a 6.3 V AC power supply for heating filaments. A High Current Sensor (PS-2193 or CI-6740) can read the current when using this power supply with interfacing experiments. Both DC and AC outputs are available simultaneously on separate floating output terminals.

#### Order Information

Tunable DC (Constant Current)  
Power Supply .....SE-9622

### DC (Constant Voltage) Power Supply II

SE-9644

- ▶ 0 to 12 V DC, 1 A maximum
- ▶ 0 to 100 V DC, 30 mA maximum
- ▶ 0 to 200 V DC, 30 mA maximum

The (0 to 12 V) output is independent of the (0 to 100 V) and (0 to 200V) outputs, which share an output and are selected by pushing a button.



#### Specifications

Independent floating ground reference

**Ripple:** <1%

*Includes cords to connect to the 550 and 850.*

#### Order Information

DC (Constant Voltage)  
Power Supply II .....SE-9644

### DC Current Amplifier

SE-6621

- ▶ Detects Picoamp currents
- ▶ Six ranges from  $10^{-8}$  A to  $10^{-13}$  A



#### Specifications

Independent floating ground reference

**Maximum Voltage Input:** 15 V

**Zero drift:**  $\leq 0.2\%$  of full range  $10^{-13}$ A after 30 min.

*Includes cords to connect to the 550 and 850.*

#### Order Information

DC Current Amplifier .....SE-6621

## Tunable DC Power Supply 6A

SE-9656

- ▶ Used in Zeeman Effect experiment
- ▶ Can be used in the e/m experiment to power the coils
- ▶ Maximum current of 6 A

The Tunable DC Power Supply supplies power to the pen-type mercury lamp and the electromagnet (SE-9655) in the Zeeman Effect Apparatus (SE-9654). The output for the mercury lamp is 1500 V AC and the output for the electromagnet is zero to 6 A with a maximum voltage of 36 V DC.



### Specifications

**AC Output:** Fixed 1500 V, maximum current 145 mA

**DC Output:** Constant current: adjustable from zero to 6 A  
 Maximum voltage: 36 V  
 Digital readout  
 Extra fuse included: 250 V T5A

### Order Information

Tunable DC Power Supply 6A .....SE-9656

## Wide Range Function Generator

SB-9549A

This function generator is similar to the Basic Function Generator, but it provides a wider frequency range and greater output voltage.



### Specifications

**Ranges:** 0.2 Hz to 5 MHz in seven ranges, ( $\pm 1$  count)

**Waveforms:** sine (distortion  $< 1\%$  below 100 kHz); square (2% symmetry, 50 nS max rise and fall time); triangle (98% linearity below 100 kHz, 95% above 100 kHz)

**Outputs:** 20 Vp-p no load, 10 V p-p max into 50  $\Omega$  load; continuously variable, 20 dB range with 20 dB step; DC offset:  $\pm 10$  V (no load),  $\pm 5$  V (50  $\Omega$  load); TTL/CMOS-compatible pulse

**Sweep:** external voltage-controlled oscillator, 0-10 V signal can produce 100:1 frequency change

**Power Source:** 115/220 VAC, 50/60 Hz

**Accessories:** BNC to insulated clips

### Order Information

Wide Range Function Generator .....SB-9549A

## High-Frequency, High-Power Function Generator

SF-9580

- ▶ Wide frequency range: 0.001 Hz to 10 MHz
- ▶ 10 Watts up to 100 kHz to drive speakers
- ▶ Sweep mode
- ▶ Step mode



*Appearance may vary.*

### Simple design

For basic use, you just operate two large buttons: one for frequency, one for amplitude. That's it. If you want to change waveform or to utilise the new step and sweep modes, the display keeps you updated on the status of the generator.

### Unique frequency control

The frequency is set by a speed sensitive button. Turn slowly to set the display's last digit. Turn faster and the response accelerates softly. We have designed this function to work intuitively in practical experiments with common physics equipment.

### Drive speaker and vibrators directly

The built-in 10 W power amplifier drives effortlessly power-consuming equipment such as a vibrator or speaker. The amplifier can deliver more than 1 A for all frequencies between 0.001 Hz and 100 kHz.

### Advanced features

The generator connects to your PC through a standard USB cable. Custom defined waveforms (e.g. created by means of a spreadsheet) can be saved to the generator. Sequences of settings can be programmed for automatic execution.

### Specifications

**Bipolar:** Sine, triangle, square; **Positive:** Square pulse, triangle pulse, ramp up, ramp down

**Distortion (sine):**  $< 0.1\%$  up to 20 kHz;  $< 1\%$  otherwise

**Frequency Range:** 50  $\Omega$  and sync outputs: 0.001 Hz to 10.00 MHz; Power output: 0.001 Hz to 100.0 kHz

**Frequency Stability:** Better than 0.005 %

**Amplitude:** 50  $\Omega$  output, no load: 0 to 10 V (20 V p-p for bipolar waveforms); Sync output: 5 V (TTL signal: 0 to 5 V); Power output: 0 to 10 V (20 V p-p for bipolar waveforms)

**Max Current:** 50  $\Omega$  output, short circuit: 200 mA (only briefly); 50  $\Omega$  output, into 50: 100 mA (unlimited); Power output: 1 A (unlimited)

**Power Consumption:** 85 W (max); 21 W (idle)

**Dimensions (WxDxH):** 31.2 x 20.5 x 11.7 cm

### Order Information

High-Frequency, High-Power Function Generator .....SF-9580

# Function Generator

## Function Generator

PI-8127

- ▶ 0.001 Hz to 150 kHz
- ▶ Programmable frequency sweep
- ▶ 10 Volts at 1 amp
- ▶ Use for circuits and/or driving speakers
- ▶ Use the ramp function to vary the speed of DC motors
- ▶ Frequency resolution of 0.001 Hz over entire range



### Upgradable Firmware

Download the latest features for your PI-8127: The built-in USB port allows users to access and upgrade firmware whenever the unit is attached to a computer running current versions of PASCO Capstone™ Software (pp. 6-13).

### Features

The Function Generator outputs sine, square, triangle, positive and negative ramps in addition to DC. It's powerful output, 1 Amp at 10 Volts, makes it useful for driving speakers, string vibrators, and circuits. Set maximum current and voltage outputs for safety. The LCD display is used to show readouts of frequency, voltage amplitude, and rms current.

- ▶ **LCD Readout:** The LCD displays frequency, voltage, current, waveform, and menus. The backlight has two levels, low and high, selectable using the menu. The low backlight is useful in dark rooms.
- ▶ **Frequency/Range Selection:** There are two ranges, 0.001 Hz to 100 Hz and 1 Hz to 100 kHz, selected using the range push-button switch (integrated with the frequency knob).
- ▶ **Output Standby:** Pushing the standby button disables the output without changing settings.
- ▶ **Output Current/Voltage Maximum:** The maximum current or maximum voltage can be set using the menu. This is useful when the instructor needs to limit the voltage applied to a light bulb.
- ▶ **Offset Voltage:** Any waveform may be offset with a DC voltage ranging from -10 V to +10 V, provided the peak voltage does not exceed 10 V.
- ▶ **Frequency Sweep:** Sweep between any two frequencies at a selectable rate.

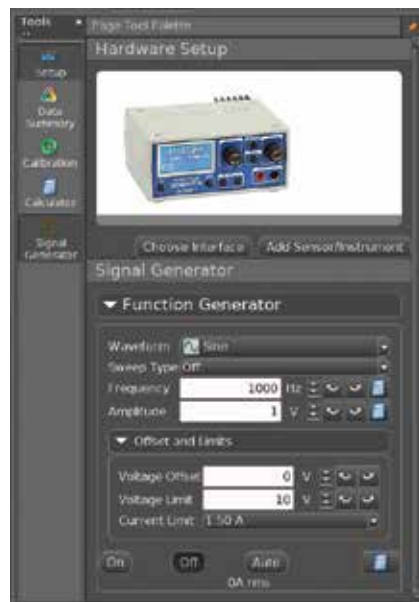
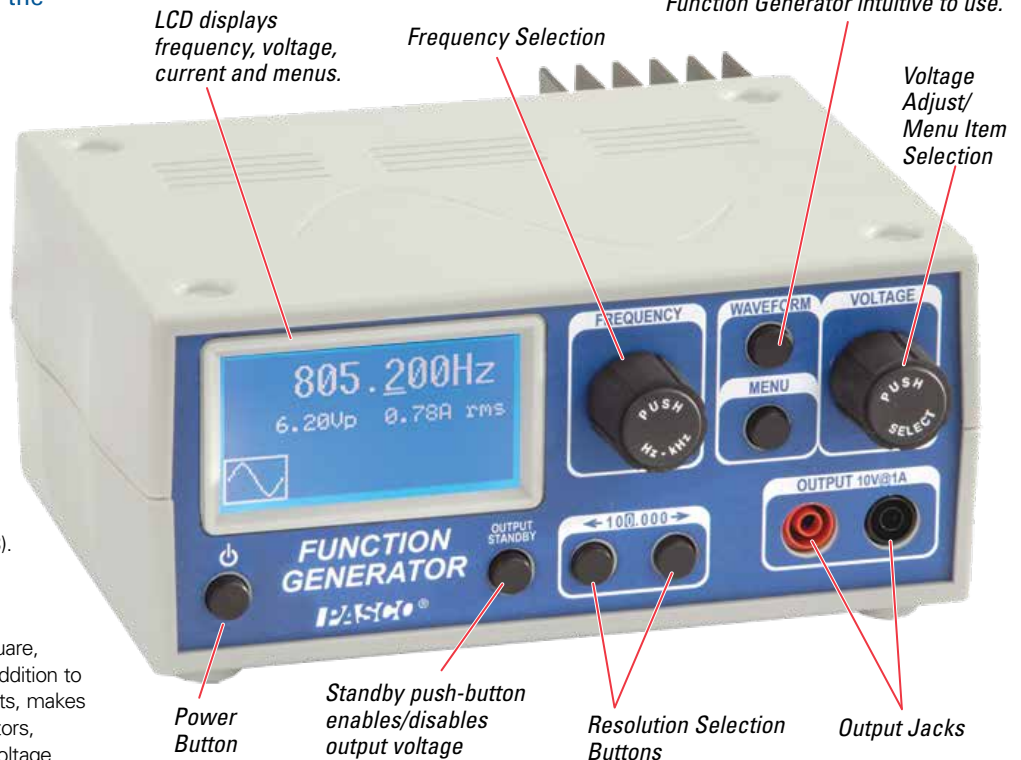

Use the Function Generator stand alone or connect to a computer via USB cable and control all its functions from PASCO Capstone™. Use it with PASPORT interfaces and sensors.

### Specifications

**Input Power:** 15 V @ 1.6 A.

**Voltage Output:** ±10 V @ 1 A.

**Frequency Range:** DC to 100 kHz. Sine wave retains its form to 150 kHz.

**Frequency Resolution:** 0.001 Hz over entire range.

**Offset Voltage:** ±10 V.

**Waveforms:** Sine, Triangle, Square, Positive Ramp, Negative Ramp, DC

**External Voltage Input:** ±10 V Maximum

**Trigger Output:** TTL Compatible; BNC jack on back of unit

**Display:** LCD Graphics Monochrome Display, 128 x 64, with Two-Level Backlight

**Displays:** Frequency, Waveform, Voltage, Current, Offset Voltage.

**Amplitude Modulation:** Modulate the signal of one function generator using another.

### Order Information

Function Generator ..... PI-8127

## Decade Capacitance Box

SE-8689



This Decade Capacitance Box supplies five decades of capacitance from 100 pF to 11.111  $\mu$ F in 100 pF steps. Add or subtract capacitance with slide switches. Three color-coded binding posts provide reliable connections.

### Specifications

**Accuracy:**  $\pm 5\%$

**Maximum Voltage:** 50 VDC

### Order Information

Decade Capacitance Box.....SE-8689

## Decade Resistance Box

SE-7124



Resistance is plainly displayed with this six-decade resistance box since a rotary switch selects the resistance within each decade. With 1% accuracy and 1/2 watt resistor, it will accommodate most student experiments.

### Specifications

**Resistance:** 0 to 1, 111, 110  $\Omega$  in 1  $\Omega$  increments

**Accuracy:**  $\pm 1.0\% \pm 0.1 \Omega$

**Power Dissipation:** 1/2 Watt resistors

### Order Information

Decade Resistance Box .....SE-7124

## Heavy-Duty Voltmeter

SF-9568A



The Voltmeter has three ranges and is switch-selectable to measure AC or DC voltages.

### Specifications

**DC Ranges:** 0 to 3 V/15 V/30 V

**AC Ranges:** 0 to 3 V/15 V/30 V

**Accuracy:**  $\pm 2\%$

**Sensitivity:** 10 k $\Omega$ /V

### Order Information

Heavy-Duty Voltmeter .....SF-9568A

## Heavy-Duty Ammeter

SF-9569A



The Ammeter has three ranges and is switch-selectable to measure AC or DC values. All ranges are overload-protected up to 15 amps.

### Specifications

**DC Ranges:** 0 to 50 mA/500 mA/5 A

**AC Ranges:** 0 to 50 mA/500 mA/5 A

**Accuracy:**  $\pm 2\%$

**Max Volt Drop:** 0.23 V

### Order Information

Heavy-Duty Ammeter .....SF-9569A

## Heavy-Duty Galvanometer

SF-9500A



A "push-to-read" switch protects the galvanometer during hookup by shunting the current through an equivalent resistor.

### Specifications

**DC Ranges:** 50  $\mu$ A/500  $\mu$ A/5 mA

**Internal Resistance:** 1.5 k $\Omega$ /170  $\Omega$ /17  $\Omega$

**Accuracy:**  $\pm 2\%$

### Order Information

Heavy-Duty Galvanometer .....SF-9500A

# Oscilloscope

## Digital Storage Oscilloscope

SB-9621A (100 MHz)

- ▶ 2-Channel 100 MHz bandwidth
- ▶ 2 M points of memory gives finer detail
- ▶ FFT/FFTrms/Zoom FFT
- ▶ Delay on/off
- ▶ USB Flash storage and data logger
- ▶ Go/NoGo function
- ▶ Print directly to printer
- ▶ PC remote control software



This 2-channel oscilloscope is designed to meet educational demands. With fast waveform process capability, more advanced triggering functions, and light-weight design, this oscilloscope is an excellent replacement for an analog scope.

Via the USB Device port, the user can easily build a remote control program to manipulate the machine, storing data directly into a flash drive for further analysis.

Several acquisition modes and 27 auto measurement functions help the user accurately measure waveform properties.

A total of 15 waveforms can be saved into the internal memory for later recall and display, and two saved reference waveforms plus two live waveforms can be shown on the screen at the same time for comparison.



### Specifications

**Bandwidth:** 100 MHz ,  
2 Input Channels

**Sampling Rate:** 1 GSa/s Real-Time  
and 25 GSa/s Equivalent-Time

**Record Length:** 2 Mega Points

**Vertical Scale:** 2 mV to 10 V

**Horizontal Range:** 1 ns to 50 s

**Number of Auto Measurements:**  
Up to 27

**Functions:** +, -, x, FFT, FFTrms,  
Zoom FFT

**Display:** 5.7" Color TFT LCD

**Ports:** USB Host and Device Ports

**Data Logger**

See [www.pasco.com](http://www.pasco.com) for  
complete specifications.

### Order Information

Digital Storage Oscilloscope  
100 MHz .....SB-9621A

## Precision Digital Multimeter, Component Tester, and Thermometer

SB-9631B

An excellent general purpose multimeter. Features high-accuracy overload protection on all ranges and a built-in digital thermometer. It can measure capacitance and transistor gain (hFE).



### Specifications

**DC Voltage:** 200 mV, 2 V, 20 V, 200 V, 1000 V;  $\pm (0.5\% + 1 \text{ digit})$  10 M  $\Omega$  input impedance

**AC Voltage:** 200 mV, 2 V, 20 V, 200 V;  $\pm (1\% + 4 \text{ digits})$  750 V;  $\pm (1.5\% + 4 \text{ digits})$  10 M  $\Omega$  input impedance

**DC Current:** 200  $\mu$ A, 2 mA, 20 mA, 200 mA;  $\pm (1\% + 1 \text{ digit})$

**AC Current:** 200  $\mu$ A, 2 mA, 20 mA, 200 mA;  $\pm (1.2\% + 4 \text{ digits})$

**Resistance:** 200  $\Omega$ ;  $\pm (1\% + 3 \text{ digits})$  2 k $\Omega$ , 20 k $\Omega$ , 200 k $\Omega$ , 2 M $\Omega$ ;  $\pm (0.8\% + 1 \text{ digit})$  20 M  $\Omega$ ;  $\pm (3\% + 3 \text{ digit})$

**Capacitance:** 20 nF, 200 nF, 2  $\mu$ F, 20  $\mu$ F, 200  $\mu$ F;  $\pm (3\% + 10 \text{ digits})$

**Temperature:** -4° to 1400°F; -4°F to 900°F;  $\pm 2.0\%$  reading + 4°F; 900°F to 1,400°F;  $\pm 3.0\%$  reading + 4°F

**Additional Functions:** Diode test, transistor hFE, audible continuity test, fold-out stand

**Display:** 3-1/2 digit LCD display, 17 mm high digits, polarity indication, low battery indication

**Drop Resistant**

**Power:** 200-hour life on 9 V alkaline (battery included). Test leads, temperature probe and battery are included.

### Order Information

Precision Digital Multimeter..... SB-9631B

*Replacement Supplies:*

Thermocouple Probe..... SB-9632

## Digital LCR Meter

SE-8792



Measure inductance, capacitance, and resistance. Test leads are included, along with a battery, a protective holster, and a manual.

### Features

▶ **Accuracy:** 1% or better on most ranges

▶ **Easy to Use:** Push-button selection for all measurements

▶ **Digital Display:** 4-1/2 digit backlit LCD

▶ **Built-in Tilt Stand:** Convenient tabletop use

### Specifications

**Inductance:** 2000.0  $\mu$ H, 20.000 mH, 200.00 mH, 2000.0 mH, 20.000 H, 200.00 H, 20.000 H ( $\pm 0.7\%$  rdg + Lx/10000 + digit)

**Capacitance:** 2000.0 pF, 20.000 nF, 200.00 nF, 2000.0 nF, 20.000  $\mu$ F, 200.00  $\mu$ F, 2000.0  $\mu$ F ( $\pm 0.7\%$  rdg + 5 digit)

**Resistance:** 20.000  $\Omega$ , 200.00  $\Omega$ , 2.0000 k $\Omega$ , 20.000 k $\Omega$ , 200.00 k $\Omega$ , 2.0000 M $\Omega$ , 20.000 M $\Omega$  ( $\pm 0.5\%$  rdg + 8 digit)

**Power:** 9 V alkaline battery (included)

**Accessories:** Test leads (2), alligator clips (2), protective holder

### Order Information

Digital LCR Meter..... SE-8792

## Basic Digital Multimeter

SE-9786A

This basic meter includes all functions and ranges needed for most introductory lab work.

### Features

▶ 20 Amp range

▶ Backlit display with 25 mm digits

▶ Soft rubber boot for drop protection

▶ Built-in tilt stand

▶ Type K thermometer built in for surface or air measurements

▶ Auto power off saves battery life

### Specifications

**DC Voltage:** 0.1 mV to 600 V with  $\pm 0.5\%$  accuracy

**AC Voltage:** 1 mV to 600 V with  $\pm 0.3\%$  accuracy

**DC Current:** 0.1  $\mu$ A to 20 A

**AC Current:** 0.1 mA to 20 A

**Resistance:** 0.1  $\Omega$  to 20 M $\Omega$

**Additional Functions:** Input fuse protection, audible and visible misconnection signals, data hold freeze display reading

**Display:** 3-1/2 digit display with 25 mm digits, polarity indication, low battery indication

**Power:** 9 V battery (included)



### Order Information

Basic Digital Multimeter..... SE-9786A

# Ripple Tank

## Ripple Tank System

WA-9899

- ▶ Completely redesigned system
- ▶ More affordable
- ▶ Integrated strobe/ripple generator simplifies operation
- ▶ Foam "beach" design dramatically reduces reflections from walls
- ▶ Silent operation

The redesigned Ripple Tank System is easier to use, more reliable, and more affordable. The strobe and rippler are controlled by the same unit, and a new feature makes it possible to introduce a small frequency difference between the strobe and the rippler to make the waves appear to move slowly. A simple switch changes the phase of the two rippers from 0 to 180 degrees.

The rippler uses voice coil actuators for precise and silent operation. The frequency range (1.0 Hz to 50.0 Hz) includes those important low frequencies that make refraction more prominent. The LED digital frequency readout can be seen in low lighting. The rippler has knobs to easily adjust the dipper depth and the amplitude of the dipper stroke.

The new light source is a white LED that remains cool during operation and produces a bright, clear wave pattern. The light can be used as a strobe or in steady mode.

### Typical Applications

- ▶ Speed of Wave Propagation
- ▶ Superposition of Waves
- ▶ Effects of Varying Water Depth
- ▶ Reflection, Refraction, and Diffraction

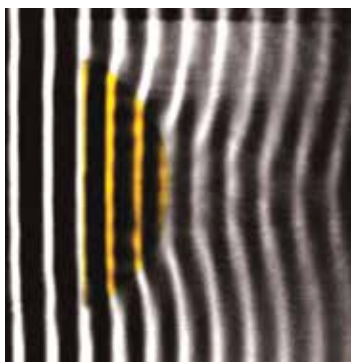

The yellow convex lens focuses the plane water waves. The waves show a pronounced refraction due to the abrupt change in depth of the water over the plastic lens.

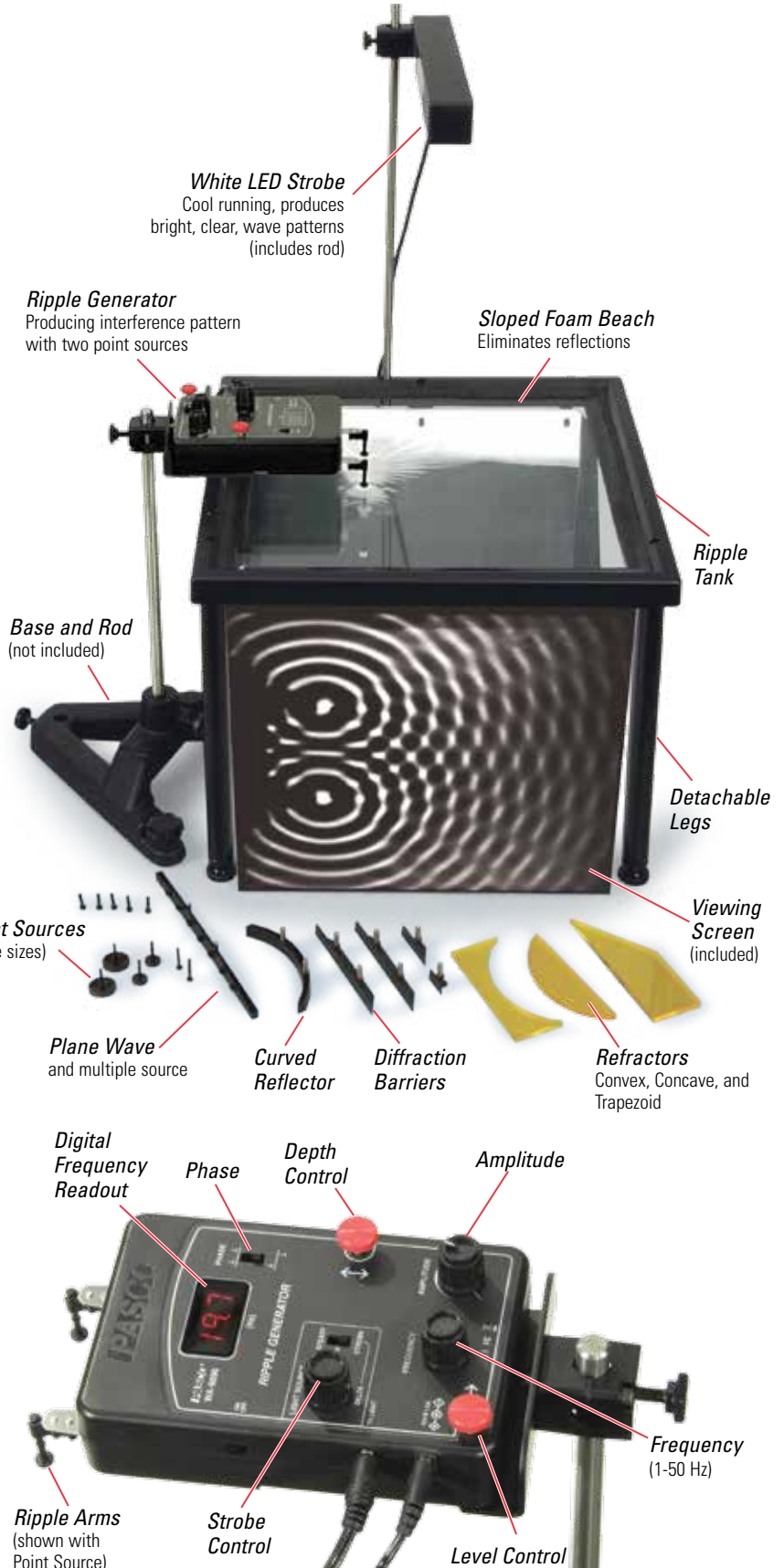

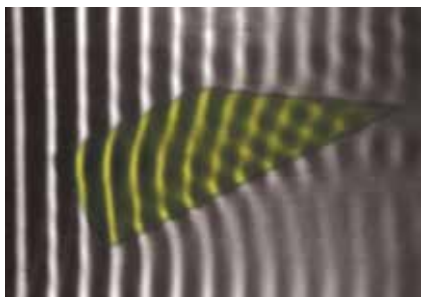

Refraction occurs at the boundaries of this rhomboid shape.



The Doppler Effect is clearly demonstrated by moving the dipper. In this picture the movement is downward.



Diffraction Barriers are used to create a double slit to show interference. The barriers can be changed to adjust the slit width and slit separation.

**Specifications – Ripple Tank (WA-9897)**

- Viewing Area:** 34 cm x 34 cm
- Usable Tank Depth:** 1 cm
- Drain Tube:** 30 cm long
- Projection Screen:** 35.6 cm x 38.8 cm wide
- Acrylic Mirror:** 49.8 cm x 38.8 cm wide
- Light Source Support Rod:** 46 cm long
- Water-Resistant Storage Box:** 64 cm x 52 cm x 17 cm

**Specifications – Ripple Generator/Light Source (WA-9896)**

- Voice Coil Actuator Frequency Range:** 1.0 to 50.0 Hz with 0.1 Hz Resolution
- Light Source:** Strobe or Steady, 5 W White LED
- Digital LED Display:** Frequency/Delta
- Adjustable Delta Frequency Between Ripple Generator and Strobe:** ± 45% frequency setting in steps of 9%
- Phase Switch:** 0 or 180 degrees  
Depth, Tilt, and Amplitude Adjustment Controls
- Power Supply:** 15 VDC at 1.5 A with On/Off Switch
- Rippler Case Dimensions:** 10.5 cm x 16.3 cm x 3.9 cm

**Includes**

- Ripple Tank (complete components list at right)
- Ripple Generator/Light Source (complete components list at right)
- Water Resistant Storage Box included (64 cm x 52 cm x 17 cm)



**Order Information**

Ripple Tank System .....	WA-9899	
<i>Required:</i>		
Large Rod Base .....	ME-8735	p. 176
90 cm Rod .....	ME-8738	p. 176
<i>Replacement:</i>		
Ripple Tank Replacement Set.....	WA-9898	

**Ripple Tank**

WA-9897



**Includes**

- Tank with Legs
- Projection Mirror and Screen
- Strobe Mounting Rod
- Refractors (convex, concave, rhomboid)
- Curved Reflector
- Diffraction Barriers (2 long, 1 short, 1 mini)
- Plastic Storage Box for components
- Surfactant
- Drainage Tube (30 cm) with Clamp
- 1 liter Plastic Beaker
- Pipette
- Clear Plastic Ruler
- Water Resistant Storage Box for Entire System

See specifications at left.

**Order Information**

Ripple Tank..... WA-9897

**Ripple Generator/Light Source**

WA-9896



**Includes**

- Ripple Generator/Strobe Driver with Power Adapter
- LED Strobe Assembly
- Plane Wave Generator with Multi-point Dippers
- Point Sources (3 sizes)

See specifications at left.

**Order Information**

Ripple Tank Generator/ Light Source..... WA-9896

**Ripple Tank Replacement Set**

WA-9898

**Includes**

- Plastic Storage Box for Components
- Dippers
- Pipette
- Foam Beach
- Refractors
- Curved Reflector
- Diffraction Barriers

See specifications at left.

**Order Information**

Ripple Tank Optics..... WA-9898

# Standing Waves

## String Vibrator

WA-9857A

- ▶ Great tool for mechanical wave demonstrations
- ▶ Uses magnetic field to drive flexible tongue

The String Vibrator transforms mechanical wave demonstrations to hands-on activities that every lab group can easily perform. Featuring an elegant design with no motors or speakers, the String Vibrator allows students to study the fundamental characteristics of mechanical waves including wave speed, frequency, wavelength, amplitude, interference, and resonance.

### Includes

- String Vibrator Unit
- Wave Cord (3 meters) (not shown)



### Order Information

String Vibrator ..... WA-9857A  
 Required:  
 Sine Wave Generator ..... WA-9867

**Clamping**  
 Convenient for clamping the String Vibrator to the tabletop or any other edge. Holes allow permanent mounting to a surface.

### Power Inputs

Drive String Vibrator's coil with Sine Wave Generator or 850 Interface.

### Stainless Steel Tongue

Flexible metal strip mounted to a powerful neodymium magnet; includes a hole for connecting string or wave cord.

### Air Vents

Provide good circulation of air around coil.

### Custom Plastic Case

Tough enough for student use; stacking posts allow several units to be vertically stacked for storage.



## Strobe

ME-6978

- ▶ 1 Hz to 500 Hz
- ▶ Variable intensity
- ▶ Low cost
- ▶ External trigger

Unique modular design makes it easy to light any geometry. The Strobe includes the Strobe Control Box and one Strobe Module. Additional Strobe Modules can be purchased separately (see below) for up to a total of four lamp modules per controller, and multiple control boxes can be connected together using the External Trigger. The Strobe Modules have a tilting lamp head on a sturdy base that sits on the table or fastens to a rod stand.



### Digital Display



Tilting lamp head on a sturdy base sits on the table or fastens to a rod stand.

### Includes

- Control Box
- Strobe Module (1)

### Specifications

**Frequency Range:** 1 Hz to 500 Hz  
**Resolution:** 0.1 Hz  
**Accuracy:** 0.1%  
**Lamp Life:** 50,000 hours.  
**Brightness:** 230 lumens (peak) per module

### Order Information

Strobe ..... ME-6978  
 Additional Strobe Module ..... ME-6982  
 Shown in use with:  
 String Vibrator ..... WA-9857  
 25 cm long Steel Rod (2) (threaded) ..... ME-8988  
 Aluminum Table Clamp (2) ..... ME-8995  
 Sine Wave Generator ..... WA-9867  
 Multi-Clamp ..... ME-9507

p. 176

## Sine Wave Generator

WA-9867

- ▶ Sine wave output up to 800 Hz
- ▶ Ideal for driving speakers and wave drivers
- ▶ Auto-scan of resonant frequencies

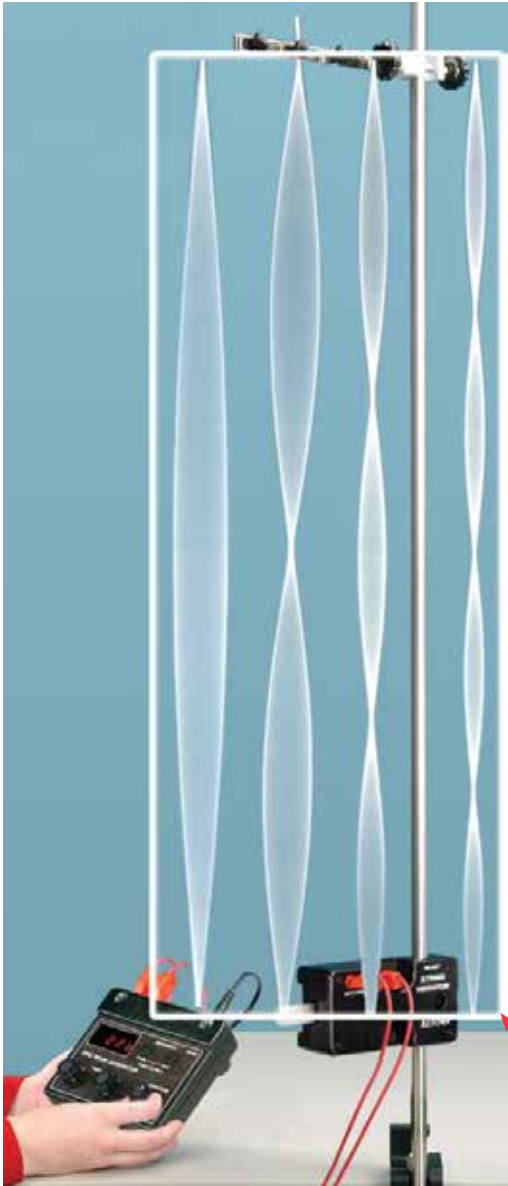

### Includes

- Sine Wave Generator
- Power Supply: 15 VDC 2A



**LED Display**  
Red LEDs make the display easy to read with 0.1 Hz resolution.

**Power Output**  
Standard banana jacks allow the Sine Wave Generator to be easily connected to other devices.

**Frequency Increments**  
Use these buttons to store a frequency increment and scan through a frequency range by this increment.

**Amplitude**  
Vary the amplitude of the sine wave 0 to 10 V peak.

**Frequency Adjustment**  
Change the frequency by 1 Hz or 0.1 Hz increments.



**High Power Output**  
To drive speakers.

### Features

- ▶ **Custom Plastic Case:** Designed to withstand student use; includes angled rubber feet for ease of use and rear rod clamp for additional mounting options. Cases are also stackable for easy storage.
- ▶ **Digital Display:** Frequency is displayed with 0.1 Hz resolution using red LEDs.
- ▶ **Frequency Adjustment:** Adjust the frequency of the output with either the fine (0.1 Hz) or coarse (1 Hz) knobs. The knobs include a "smart scan" feature so they change frequency more quickly when continuously turned.
- ▶ **Amplitude Adjustment:** Change the voltage of the sine wave signal.
- ▶ **"Learn" Frequency:** The Sine Wave Generator will store a frequency increment, then it will cycle through the selected frequency range by the increment automatically, which is very useful for resonance demonstrations or activities.

### Order Information

Sine Wave Generator.....	WA-9867	
<i>Recommended:</i>		
String Vibrator .....	WA-9857A	p. 244
Mechanical Wave Driver .....	SF-9324	p. 246
Open Speaker.....	WA-9900	p. 248
Economy Resonance Tube.....	WA-9495	p. 248
<i>Shown in use with:</i>		
2 Meter Patch Cord Set.....	SE-9415A	p. 216

# Mechanical Waves

## Mechanical Wave Driver and Accessories

### Mechanical Wave Driver

SF-9324

- ▶ Drive any wave experiment at specified frequencies
- ▶ Variable amplitude
- ▶ Tough and versatile

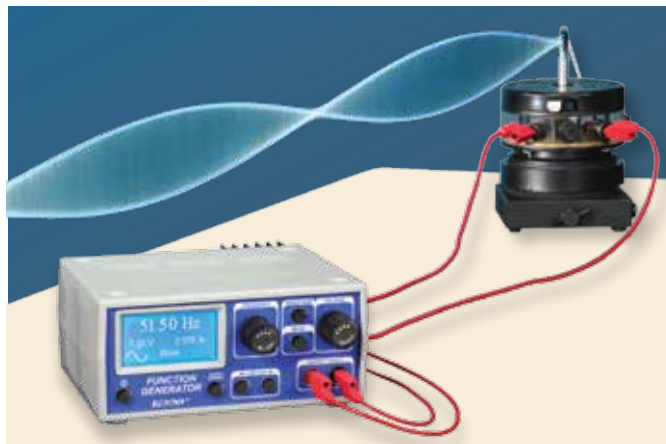

SF-9324  
8 Ω Impedance

#### Powering the Wave Driver

Different PASCO products can be used to power the Wave Driver; see below.

#### Features

**Frequency Response:** From 0.1 to 1000 Hz with an amplitude of approximately 5 mm up to about 50 Hz.

**Mounts Vertically or Horizontally:** Designed to sit upright on a table, on its side, or mounted on a 12.7 mm (1/2 inch) rod.

**Driving Signal Required:** Requires a function generator with a minimum of  $\pm 8 \text{ V}@0.5 \text{ A}$ . An accurate measurement of frequency is necessary for quantitative resonance experiments.

#### Order Information

Mechanical Wave Driver .....	SF-9324	
<i>Required:</i>		
Banana Plug Patch Cord .....	SE-9751	p. 216
<i>Plus one of the following function generators:</i>		
Sine Wave Generator.....	WA-9867	p. 245
Function Generator.....	PI-8127	p. 238
850 Universal Interface.....		p. 12
<i>Equivalent function generator providing up to 1 A to an 8 Ω impedance.</i>		
<i>Shown in use with:</i>		
2 Meter Patch Cord Set.....	SE-9415A	p. 216
<i>Recommended:</i>		
Slot String Holder (set of 4).....	SF-9322	
Hole String Holder (set of 4).....	SF-9323	

### Longitudinal Wave Spring

WA-9401

Using the Longitudinal Wave Spring accessory, it is easy to demonstrate and visualize the nodes and antinodes of longitudinal waves.

Unstretched length is 13 cm.



*Longitudinal waves can be easily demonstrated with the Longitudinal Wave Spring.*

#### Order Information

Longitudinal Wave Spring ..... WA-9401

### Violin Chladni Plate

SE-7319

This 40 cm-long plate is shaped like a standard violin. Place sand on the plate and excite with either a violin bow or wave driver. Includes a standard banana jack connector for use with the Mechanical Wave Driver.



#### Order Information

Violin Chladni Plate..... SE-7319

### Chladni Plates Kit

WA-9607

In the early nineteenth century, Ernst Chladni added another dimension to wave experiments by sprinkling sand on a thin plate and using a violin bow to induce vibrations. The sand that collected along the nodal lines of the wave patterns painted clear and beautiful pictures of the various modes of vibration.

The Chladni Plates Kit and a Wave Driver allow continuous vibrations to be produced at measurable frequencies. Students can determine the resonant frequencies of the plates and examine the modes of vibration at any frequency.

The Chladni Plates Kit includes a 24 cm x 24 cm square plate, round plate, 0.8 kg of extra-fine sand, and a sand shaker. The round plate can be vibrated about its center or about an offset point to investigate both symmetric and asymmetric modes of vibration.



#### Order Information

Chladni Plates Kit ..... WA-9607

Mechanical Wave Driver Accessories

Metal Resonance Strips

SF-9404

These resonance strips demonstrate standing waves, harmonics, and the relationship between length, frequency, and resonance.



Investigate the unique resonant frequencies of the Metal Resonance Strips.

Order Information

Metal Resonance Strips.....SF-9404

Resonance Wire Loop

SF-9405

Use this wire loop (29 cm diameter) to introduce Bohr's quantum atom using a classical model.



Order Information

Resonance Wire Loop.....SF-9405

String Holders

4 mm diameter banana plugs fit into shaft of Wave Driver (SF-9324).



Slot (set of 4)  
SF-9322



Hole (set of 4)  
SF-9323

Order Information

Slot String Holder (set of 4).....SF-9322  
Hole String Holder (set of 4).....SF-9323

Structures Resonance

Structures System

PASCO's Structures System is ideal for demonstrating resonance in complex systems. The plastic I-Beams clearly show two different bending moments and can be connected together to build a variety of structures. See page 254 for more examples.

The long plastic I-Beam is constructed of components from the Advanced Structures Set (p. 145). It is driven using the Mechanical Wave Driver and the Function Generator (PI-8127), demonstrating the three lowest harmonics.

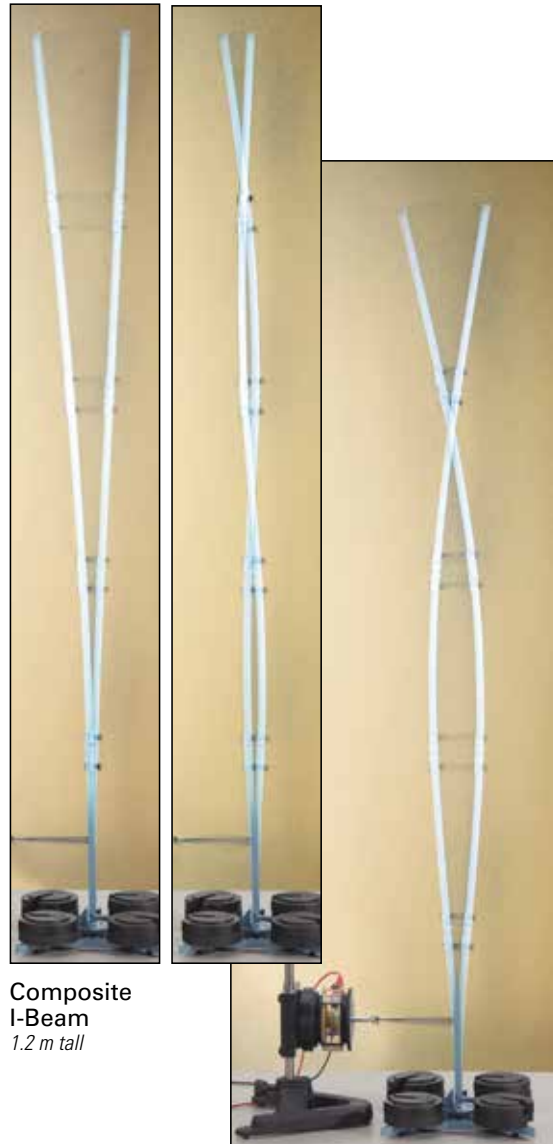

Composite I-Beam  
1.2 m tall

Order Information

Advanced Structures Set..... ME-6992B p. 143  
Large Slotted Mass Set..... ME-7566 p. 187  
45 cm Stainless Steel Rod..... ME-8736 p. 176  
Large Rod Base..... ME-8735 p. 176

# Resonance

## Demonstrate Acoustic Resonance

### Economy Resonance Tube

WA-9495



**Metric Scale**  
Directly measures length of air column for open and closed tube.

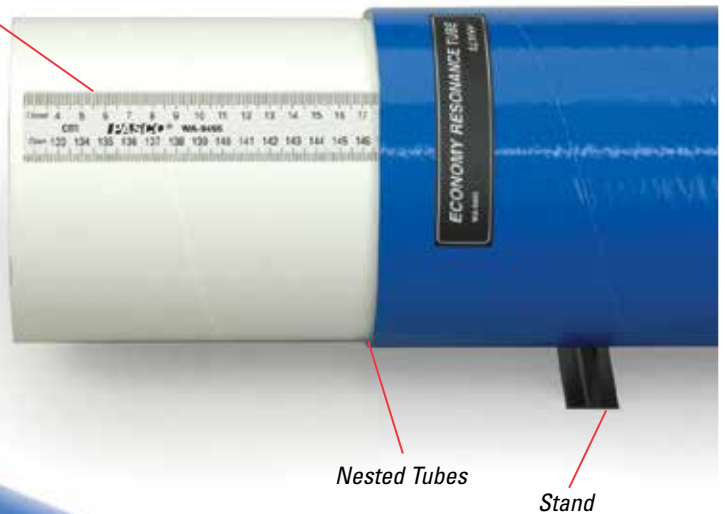

Students will have no difficulty hearing resonant frequencies from this tube. Two nested cardboard tubes allow the length of the air column to be easily varied. And the inner tube contains a removable end-cap to change from a "closed" to an "open" tube. The length of the resonating column can be read directly off the metric scale for both open and closed operation.

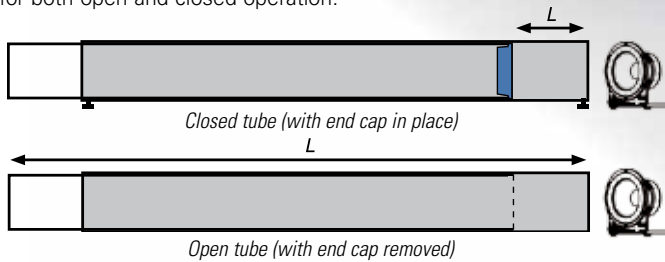

The removable end-cap on the inner tube allows the air column to act as either an "open" or a "closed" tube.



Shown in use with the Open Speaker and the Sine Wave Generator

### Open Speaker

WA-9900

Features a high-quality, 13.3 cm woofer mounted on a sturdy base with standard banana jack inputs. The Open Speaker is not enclosed inside a case, making it perfect for resonance experiments.



#### Specifications

**Frequency Response:** 75 - 8000 Hz

**Impedance:** 8 ohms

**Input Power:** 60 watts (max)

#### Order Information

Open Speaker ..... WA-9900

#### WA-9495 includes

- Outer Tube (length 1.3 m; diameter 0.15 m)
- Inner Tube (includes measuring tape and removable end-cap)
- Tube Stands (2)

#### Order Information

Economy Resonance Tube ..... WA-9495

Shown in use with:

Open Speaker ..... WA-9900

Sine Wave Generator ..... WA-9867

2 Meter Patch Cord Set ..... SE-9415A

p. 245

p. 216

## Resonance Air Column with Speaker

WA-9594

- ▶ Very loud resonance
- ▶ Tough polycarbonate tube
- ▶ Use with speaker or tuning fork

The Resonance Air Column (WA-9606) emits a very loud sound when the plunger is moved to a node position. It works as well as a water column but without the mess. The secret is in the long molded piston head, which is very efficient in reflecting the sound waves. The plunger handle is made of flexible acetyl so it will not break.

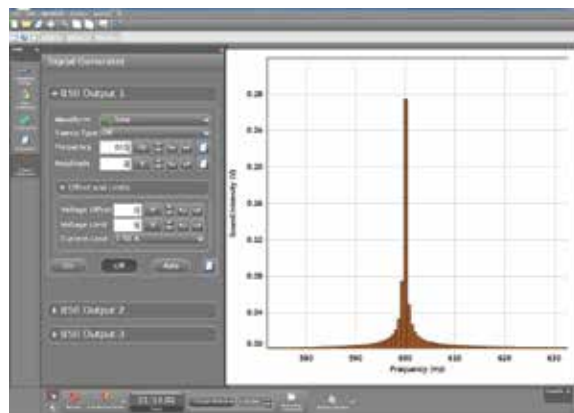

PASCO Capstone controls the sine wave output of the 850 Universal Interface to drive the speaker. The FFT display of the Sound Sensor data shows the tube's resonant response.

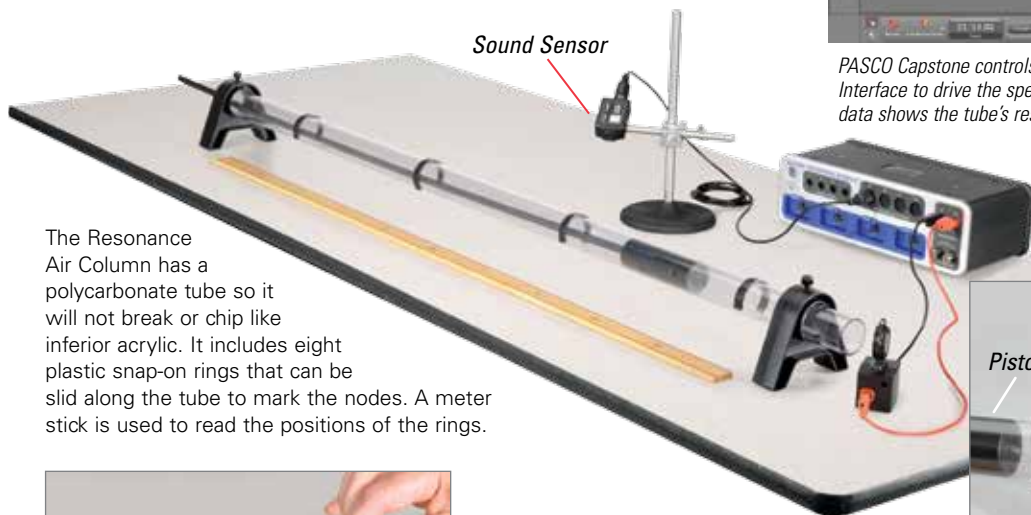

The Resonance Air Column has a polycarbonate tube so it will not break or chip like inferior acrylic. It includes eight plastic snap-on rings that can be slid along the tube to mark the nodes. A meter stick is used to read the positions of the rings.



The Resonance Air Column can be used as a closed or open tube. In the closed mode, tuning forks or speakers are suitable for sound sources. In the open mode, a speaker with a signal generator is required to vary the frequency until the tube sounds a resonance.

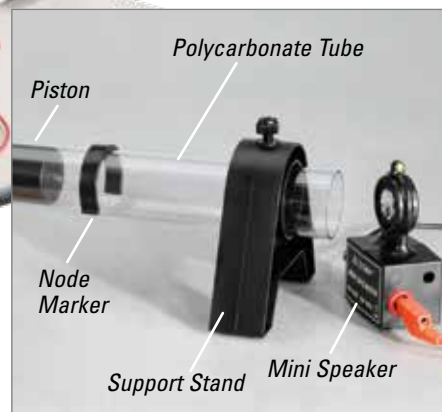

### Specifications

- Material:** Polycarbonate
- Length:** 4.0 ft (1.2 m)
- Diameter:** 1.5" O.D. (3.8 cm)
- Wall thickness:** 1/16" (1.6 mm)
- Plunger Length:** 4.2 ft (1.3 m)
- Plunger Handle:** Acetyl

### WA-9594 includes

- Resonance Air Column (WA-9606)
- Mini Speaker (WA-9605)

### WA-9606 includes

- Tube and plunger,
- Node markers (8)
- Detachable stands (2)

### Order Information

Resonance Air Column with Speaker .....	WA-9594
Resonance Air Column (without speaker).....	WA-9606
<i>Shown in use with:</i>	
850 Universal Interface.....	UI-5000 p. 12
Sound Sensor .....	CI-6506B p. 57
Tuning Fork Set.....	SE-7342 p. 253
2 Meter Patch Cord Set.....	SE-9415A p. 216
Meter Stick (6 pack).....	SE-8827 p. 182



## Mini Speaker

WA-9605

The Mini Speaker (WA-9605) is specially made to work with the Resonance Air Column. It can be powered with the Function Generator (PI-8127) or an 850 Universal Interface (UI-5000). It is also useful as a stand-alone speaker for doing interference demonstrations. Two of these essentially point sources can output the same frequency and the spatial interference pattern can be explored.

### Specifications

- Maximum Voltage:** 10 V
- Power:** 2 W
- Impedance:** 8 Ω
- Protection Resistor:** 15 Ω, 2 W



### Order Information

Mini Speaker .....WA-9605

# Transverse Waves

## Complete Wave Motion Demonstrator

SE-9600

- ▶ Produces slow-moving, high-amplitude transverse waves
- ▶ Demonstrates all basic wave phenomena

The PASCO Complete Wave Motion Demonstrator allows mechanical waves to be created to demonstrate the behavior and properties common to many types of waves.

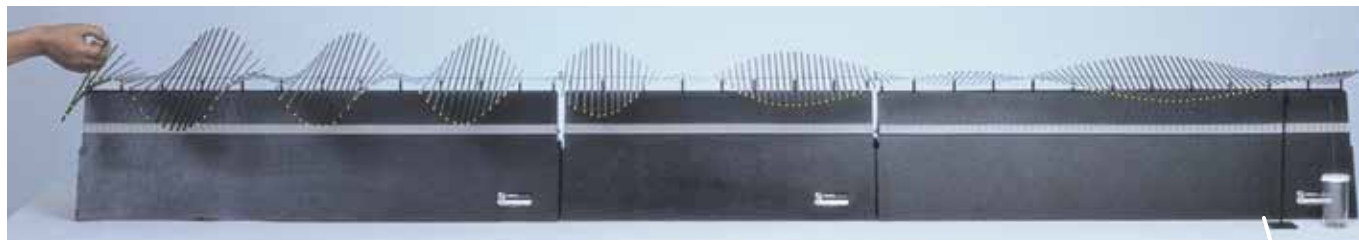

The Complete Wave Motion Demonstrator in three sections: The high-amplitude, slow-moving waves provide a fascinating introduction to basic wave phenomena.

### Features

- ▶ **2.3 Meters Long:** Plenty of room to watch the wave develop and interact.
- ▶ **Three Wave Sections:** Each section has rods of different lengths, allowing reflection and transmission demonstrations.
  - Section 1 is 92 cm long with 46 cm rods.
  - Section 2 is 92 cm long with 23 cm rods. The resulting wave velocity is about three times as fast.
  - Section 3 is 46 cm long with rods that vary exponentially from 46 cm to 23 cm. This section acts as an impedance-matching unit.
- ▶ **Yellow Rod Tips:** Easy viewing and highlights wave motion.
- ▶ **Folds** for Compact Storage
- ▶ **Easy Setup**

### How It Works

A series of steel rods is attached at their centers to a torsion wire. When a rod is displaced and released, a wave propagates along the rod. Velocity depends on the torsion constant of the wire and the moment of inertia of the rods.

### Order Information

Complete Wave Motion Demonstrator.....SE-9600

## Wave Motion Actuator

SE-7125

- ▶ Sinusoidal driver
- ▶ Reproducible pulse
- ▶ Digital readout

The Wave Motion Actuator sinusoidally drives the Complete Wave Motion Demonstrator (above). It can also generate a reproducible pulse. The Actuator arm is magnetically coupled to the rod of the Wave Demonstrator.

The frequency of the sine wave is continuously variable from 0.1 Hz to 3 Hz and the frequency and period are displayed on the digital readout.

### Demonstrate:

- Wave propagation velocity
- Wave reflection boundary conditions
- Wave interference and standing waves



### Order Information

Wave Motion Actuator .....SE-7125

## Single Section Wave Motion Demonstrator

SE-9601

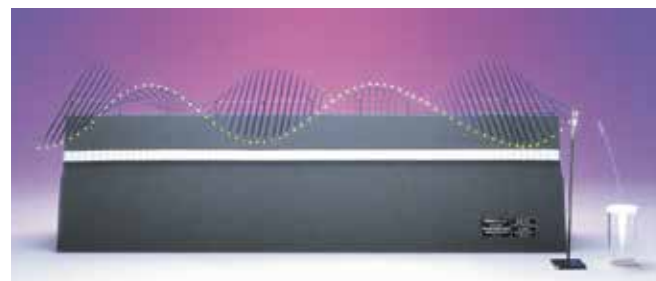

A-frame design collapses for easy storage.

### Includes

- Section 1 (46 cm long rods)
- Length of section: 92 cm
- Clamp for rigid termination
- Dash pot for liquid damping

### Order Information

Single Section Wave Motion Demonstrator .....SE-9601

### Snakey

SE-7331



Easily create clear standing wave patterns.



This extra-long metal spring is ideal to study mechanical waves. The Snakey has an unstretched length of 2 meters. Pull the convenient end loops more than 10 meters apart to demonstrate transverse, longitudinal, and standing waves.

#### Order Information

Snakey .....SE-7331

### Glow String (2 pack)

SE-8690



**WARNING**  
**CHOKING HAZARD**  
Small parts. Not for children under 3 years.

This string glows in the dark after being exposed to light. Use it to demonstrate wave motion, including resonance and standing wave patterns. Two rolls are included, totaling over 15 meters of string.

Color of string may be different from that shown.

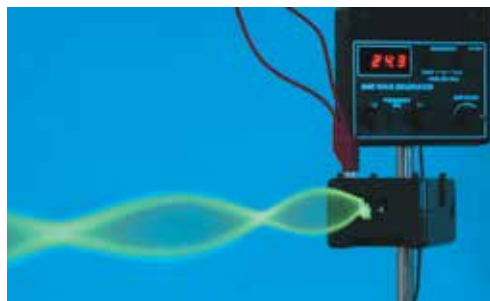

Glow String forming a standing wave using PASCO's String Vibrator WA-9857, Sine Wave Generator WA-9867, and a UV Light Source.

#### Order Information

Glow String (2 pack) .....SE-8690

### Double-Length Slinky

SE-8760



The Slinky is an excellent tool for demonstrating transverse and longitudinal wave phenomena. This Double-Length Slinky is twice as long as a traditional slinky, allowing students to create well-defined wave pulses and standing wave patterns. The tension in the Slinky is very low, causing wave pulses to travel slowly throughout its length.

#### Order Information

Double-Length Slinky ..... SE-8760

### Elastic Wave Cord

SE-9409



This highly visible elastic cord can be used to set up standing transverse waves. Or pluck it to watch wave propagation. Approximately 3 mm diameter and 90 meters in length.

#### Order Information

Elastic Wave Cord .....SE-9409

# Oscillations, Waves, and Sound

## Curriculum

### Oscillations, Waves, and Sound Teacher Resources

EP-6480

- ▶ 5 interactive simulations
- ▶ 8 interactive equations
- ▶ 13 slide presentations
- ▶ 13 lesson plans
- ▶ 13 student assignments
- ▶ Requires Waves and Sound Equipment Kit

Teach the science and technology of waves and sound. Lessons cover harmonic motion, waves, sound, period, frequency, wavelength, resonance, Doppler effect, interference, frequency spectrum, multi-frequency sound, digital sound, human perception, and music.

This electronic module runs locally on any device. No installer is required; just copy the folder over to your Mac® or Windows® computer, Chromebook™, or iPad®. Students read and interact with the physics lessons directly on their device or computer. For more information, visit [pasco.com](http://pasco.com)



## Equipment

### Oscillations, Waves & Sound Equipment Kit

EP-3578

The Waves and Sound Equipment Kit gives you the fundamental tools you need to teach harmonic motion, waves, and sound. Our “slinky” and “snakey” springs are high-quality metal (not plastic), and four steel tuning forks are great for making the connection between science and music.

#### Includes

- Steel transverse wave “snakey” spring (1.8 m)
- Extra-large steel longitudinal wave “slinky” spring
- 25 cm extension spring
- Pendulum/spring hanger
- Resonance lever
- 1” diameter aluminum pendulum ball
- Resonance tube
- Tuning fork 256 Hz
- Tuning fork 320 Hz
- Tuning fork 284 Hz
- Tuning fork 512 Hz



#### Order Information

Oscillations, Waves, & Sound	
Teacher Resources.....	EP-6480
Oscillations, Waves, & Sound Equipment Kit .....	EP-3578
<i>Required:</i>	
Tripod Stand .....	EP-3572
Weights.....	EP-3563

### Tripod Stand

EP-3572

#### Includes

- 68.6 cm extruded aluminum vertical rail
- Wide tripod base with aluminum legs and rubber feet
- Includes 5 sliding 14-20 inserts, already installed

#### Order Information

Tripod Stand .....EP-3572

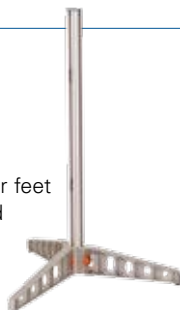

### Weights

EP-3563

#### Includes

- 2 mass hangers
- 25 fender washer masses

#### Order Information

Weights.....EP-3563



## Doppler Rocket

WA-9826

- ▶ Experience the frequency shift of sound waves
- ▶ Easily generate high velocity motion
- ▶ Rugged construction



**Skinned Foam Body**  
Protects buzzer during impact

**Rope Tube**  
Pass rope through to fly horizontally

*Flying Horizontally — A set of two ropes can be passed through the center of the unit. This allows students to use the included handles to propel the Doppler Rocket across the room at high velocities. The unit is guided by the ropes. Students hear the change in pitch as the Doppler Rocket flies past them.*



The Doppler Rocket combines the elements of a toy with an audio Doppler shift to create an educational experience students won't forget. The Doppler Rocket emits a true, sinusoidal sound waveform at a constant frequency of approximately 620 Hz. The circuit and speaker are housed in skinned foam that protects the unit during normal impacts. The circuit is powered by a 9 V battery. As the Doppler Rocket passes the students, they hear a noticeable shift in frequency. Velocities of 10 m/s can be easily achieved, resulting in a 20 Hz shift in frequency.

### Includes

- Doppler Rocket
- Rope (30 meters)
- Handles (4)
- Handle Cushions (4)
- Battery (9 Volt)



### Order Information

Doppler Rocket..... WA-9826

## Sympathetic Resonance Box Set

SE-7345

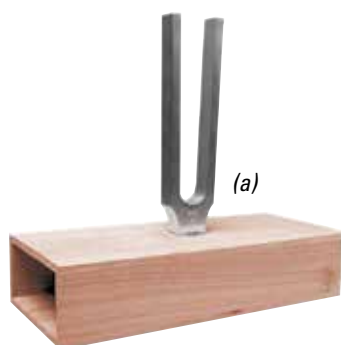
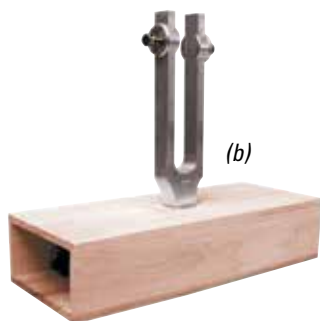

Resonance boxes are great instruments for amplifying sound from a tuning fork. These boxes are constructed from hardwood and feature an A4 tuning fork mounted directly to the box. Use Capstone software and a sound sensor (CI-6506B) to measure the sound waves and beat frequencies created by these resonance boxes.

### Includes

- Hardwood resonance box with a 256 Hz A4 tuning fork (a)
- Hardwood resonance box with an adjustable tuning fork (b)

### Order Information

Sympathetic Resonance Box Set .....SE-7345  
*Recommended:*  
 Sound Sensor .....CI-6506B  
 850 Universal Interface .....UI-5000  
 PASCO Capstone

## Tuning Fork Set

SE-7342



The tuning fork has long been the tool of choice for helping students understand the relationship between wave frequency and pitch. These high-quality aluminum tuning forks are both rugged and economical. The set includes eight forks representing a full octave of frequencies, a soft protective case, and a rubber mallet.

Note	Frequency
C	256 Hz
D	288 Hz
E	320 Hz
F	341.3 Hz
G	384 Hz
A	426.7 Hz
B	480 Hz
C	512 Hz

### Order Information

Tuning Fork Set.....SE-7342

# Basic Optics System

## Basic Optics System

OS-8515C

- ▶ Geometric and ray optics
- ▶ Concave and convex lenses
- ▶ Concave/convex mirror

PASCO's Basic Optics System is easy-to-use, affordable, and ruggedly designed. Large 50 mm diameter optics components are mounted in protective holders that snap directly onto the aluminum track and are easy to slide and position. Built-in metric tape makes measurements of image and object distances quick and accurate for both lenses and mirrors. The versatile Light Source doubles as a tabletop ray box for studies in reflection, refraction, color addition, and Snell's Law. All the components (except the track) fit in the included custom foam storage box.

**Four 50 mm Diameter Lenses**  
+100, +200, +250, -150 mm lenses are mounted in protective holders.

**Adjustable Lens Holder**  
Use your own lenses (from 19 mm to 75 mm in diameter) or choose from our lens sets.

**Viewing Screen**  
White plastic screen snaps into the optics bench and the position of the screen can be read directly on the bench scale.

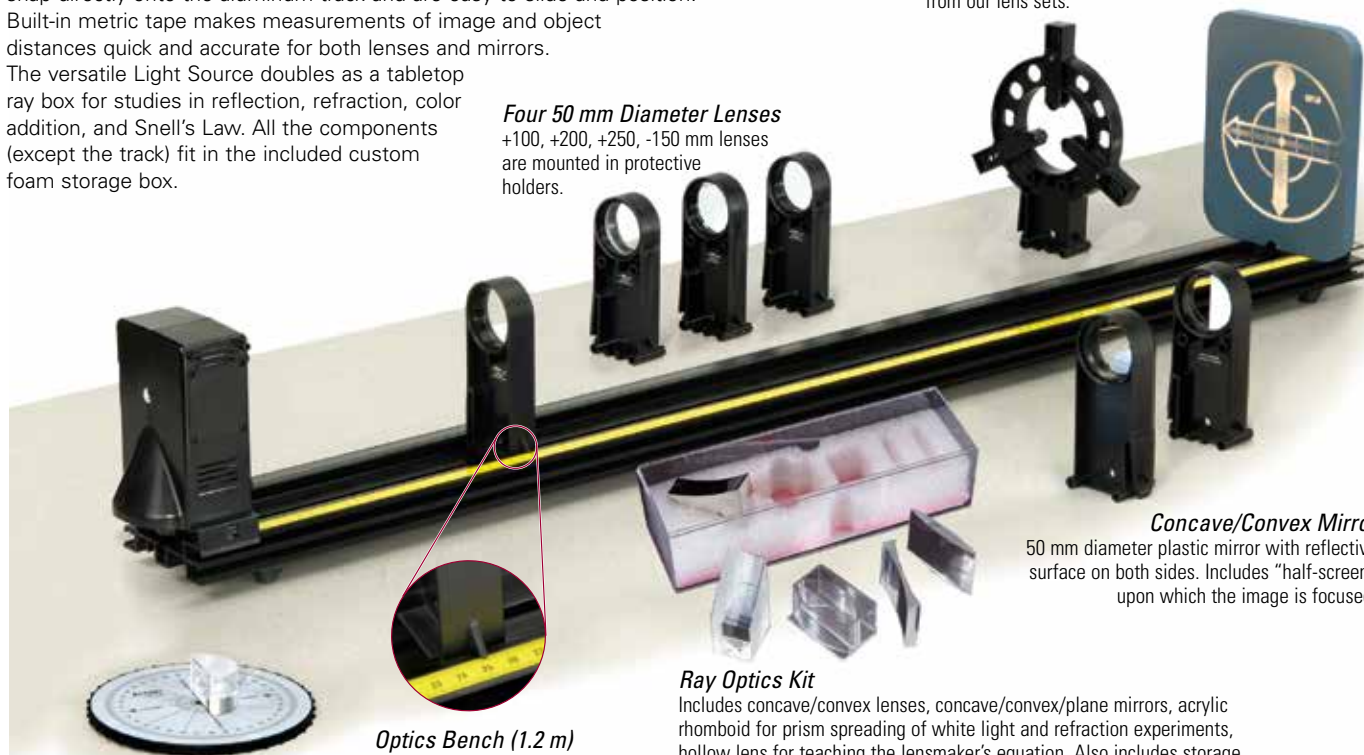

**Concave/Convex Mirror**  
50 mm diameter plastic mirror with reflective surface on both sides. Includes "half-screen" upon which the image is focused.

**Ray Optics Kit**  
Includes concave/convex lenses, concave/convex/plane mirrors, acrylic rhomboid for prism spreading of white light and refraction experiments, hollow lens for teaching the lensmaker's equation. Also includes storage tray that can be used as a water tank for the hollow lens.

**Ray Table**  
Two-piece construction allows the table to be rotated for studying Snell's Law or the Law of Reflection. Includes D-shaped acrylic lens.

**Optics Bench (1.2 m)**  
The lenses, mirrors, light source, and screen snap into this rugged aluminum extrusion. The metric tape makes position measurements easy.



Ray Table in use showing both the reflected and refracted rays.

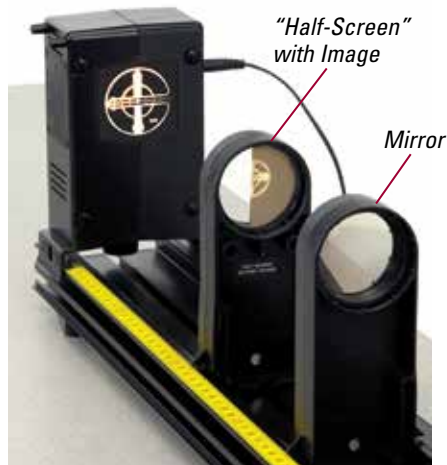

Light Source: Has a lighted crossed arrow target with metric scale for focusing images through lenses or for use with the concave mirror.

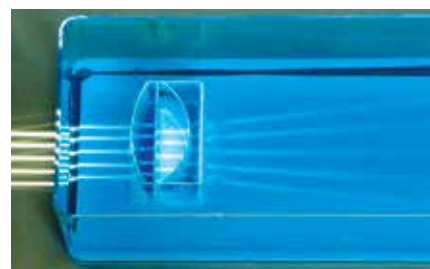

The storage tray is used to create a "hollow" air-filled convex lens. Note that the rays diverge.

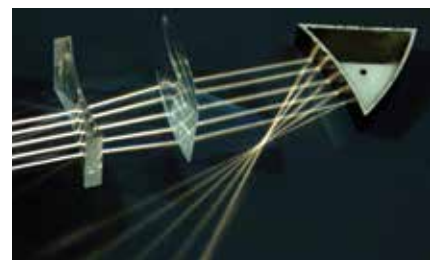

Components from the Ray Optics Kit showing refraction and reflection

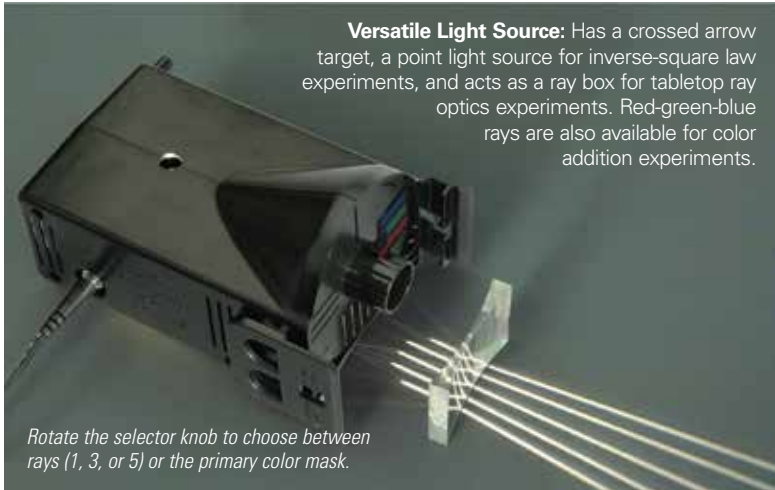

**Versatile Light Source:** Has a crossed arrow target, a point light source for inverse-square law experiments, and acts as a ray box for tabletop ray optics experiments. Red-green-blue rays are also available for color addition experiments.

Rotate the selector knob to choose between rays (1, 3, or 5) or the primary color mask.

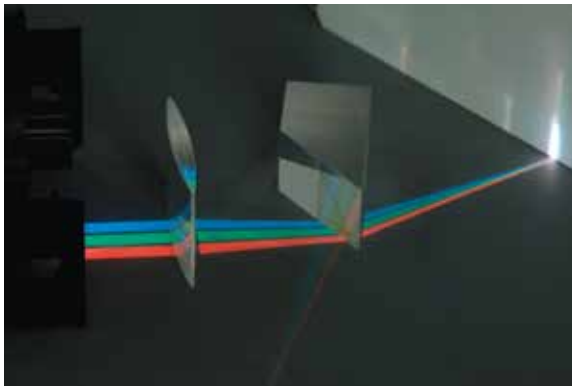

The primary color mask allows experiments in color addition using components from the Ray Optics Kit.

### Included Basic Optics System Experiments

- |                              |   |  |
|------------------------------|---|--|
| 1. Color Addition            | 7. Hollow Lens                                    | 13. Focal Length and Magnification of a Concave Mirror |
| 2. Prism                     | 8. Lensmaker's Equation                           | 14. Virtual Images                                     |
| 3. Reflection                | 9. Apparent Depth                                 | 15. Telescope  |
| 4. Snell's Law               | 10. Reversibility                                 | 16. Microscope   |
| 5. Total Internal Reflection | 11. Dispersion                                    | 17. Shadows  |
| 6. Convex and Concave Lenses | 12. Focal Length and Magnification of a Thin Lens |  |

## Basic Optics System Storage Box

All components (except the track) fit in the custom foam box. There are additional slots for accessory lenses (see page 258).



### Includes

- 1.2 m Optics Bench
- Basic Optics Light Source
- 50 mm diameter Glass Lenses in Holder +100 mm, -150 mm, +200 mm, +250 mm
- Adjustable Lens Holder
- Concave/Convex Mirror with Screen
- Ray Optics Kit
- Ray Table with D-shaped Lens
- Viewing Screen
- Storage Box

### Order Information

Basic Optics System ..... OS-8515C

## Basic Optics Components and Accessories

Pages 256-270



### System Components

pg 256



### Color Mixer

pg 260



### Lens Sets

pg 258



### System Accessories

pg 263



### Human Eye Model

pg 264-265



### Diffraction

pg 266-268

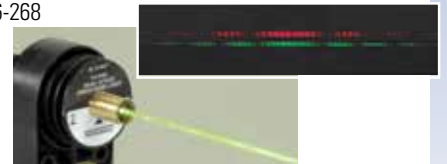

### Dynamics Track Optics

pg 270



# Basic Optics Components

## Basic Optics Light Source

OS-8470

- ▶ One, three, or five parallel rays
- ▶ Three primary color source
- ▶ Crossed arrow object and point source

The Basic Optics Light Source is an excellent source for a variety of optics experiments. A single 10-watt quartz-halogen bulb provides bright, easy-to-see illumination without a lot of heat. By turning the box to a different side, it becomes a:

1. Crossed Arrow Object with Metric Scale: ideal for showing images, focal point, and magnification.
2. Bright Point Source: The very small filament of the halogen bulb provides an excellent point source for experimenting with shadows or the Inverse Square Law.
3. Three Primary Colors Source: The red, green, and blue filters provide three rays of light that are easily combined with a lens for color mixing.
4. One, Three, or Five Ray Source: Just rotate the knob in front of the light source to vary the number of rays produced.



Rotate the selector knob to choose between rays (1, 3, or 5) or the primary color mask.



The Basic Optics Light Source provides a point source and an extremely bright crossed arrow target. Use free-standing or easily clip directly to Basic Optics Track.

### Order Information

Basic Optics Light Source..... OS-8470

## Ray Optics Kit

OS-8516A

### Includes

- Double-Convex Lens
- Double-Concave Lens
- Rhomboid
- Eye-Dropper
- Triangular mirror accessory with concave, convex, and plane reflective surfaces
- Hollow lens to fill with a liquid or use as an air lens.



### Order Information

Ray Optics Kit ..... OS-8516A

## Concave/Convex Mirror Accessory

OS-8457

- ▶ 50 mm diameter
- ▶ ±100 mm focal length
- ▶ Plastic mirror

This double-sided convex/concave plastic mirror is mounted in a lens holder for easy placement on the Basic Optics Track. The Accessory also includes a “half screen” that allows light to pass through on one side, and an opaque screen on the other half to focus the real image formed by the concave mirror.



### Includes

- Concave/Convex Mirror
- Half Screen

### Order Information

Concave/Convex Mirror Accessory ..... OS-8457

## Ray Table

OS-8465

- ▶ Angle of reflection
- ▶ Snell's Law
- ▶ Total internal reflection

The Ray Table provides an excellent viewing surface for ray optics. The table can be rotated about its axis to quickly change the incident angle of the ray. The resulting angles of reflection and refraction are easily measured directly off the polar grid printed on the table. The (included) acrylic cylindrical D lens simplifies the experiment by having the rays bend at only one surface. Investigate Snell's Law for both cases of rays either entering or leaving the acrylic.



### Includes

- Table
- D-shaped Lens

### Order Information

Ray Table ..... OS-8465

## Aperture Accessories

OS-8524

### Aperture Disk

Simulate the compound lens system of a camera using the Aperture Disk. Simply snap the disk onto one face of a lens. The disk offers six different  $f$ -number settings for controlling the amount of light that reaches the viewing screen.



The  $f$ -number is designated as  $f / \#$ , where  $\#$  equals the focal length of the lens,  $f$ , divided by the diameter of the aperture,  $D$ . (Example uses a +100 mm lens.)

$f$ -Number	Aperture Diameter (mm)
$f / 4$	25.0
$f / 5.6$	17.7
$f / 8$	12.5
$f / 11$	8.8
$f / 16$	6.3
$f / 22$	4.4

The Peripheral Mask passes light through the center only.



### Spherical Aberration Attachments

Do the center and outside parts of a lens focus light differently? With the Spherical Aberration Attachments, students will be surprised by the answer. Simply snap the attachments onto a lens from the Basic Optics System and compare the image distance for each attachment.



Peripheral Mask shown mounted on +250 mm lens.



The Center Mask passes light through an outside ring.

### Includes

- Aperture Disk and Holder
- Spherical Aberration Attachments

### Order Information

Aperture Accessories..... OS-8524

## Adjustable Lens Holder

OS-8474

The Adjustable Lens Holder for the Basic Optics System is designed for use with lenses and mirrors with diameters between 19 mm and 75 mm.

Place the lens or mirror in the holder and adjust the three arms to hold the component. A set screw in each adjustable arm ensures that the mirror or lens will remain in place. The holder snaps into the Basic Optics Track and is designed to position all mirrors and lenses at the same height as the rest of the Basic Optics System components.



Actual view through the lens of the magnified image of the pencil.

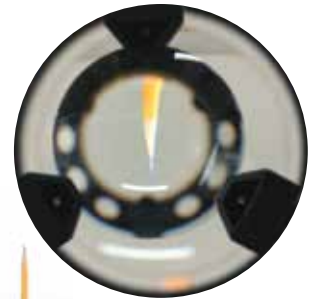

Build a telescope or microscope: Shown with 1.2 m Basic Optics Track OS-8508.

### Order Information

Adjustable Lens Holder..... OS-8474

## Lens Holder Set

OS-8522

These holders for the Basic Optics System are an excellent way to permanently mount 50 mm diameter lenses.

Just push in the two retaining rings to hold the lens in place.



### Order Information

Lens Holder Set (2 pack)..... OS-8522

# Basic Optics Accessories

## 50 mm Diameter Lens Assortment

SE-7581

This set of six lenses is made of polished glass with ground edges and comes in a wooden storage box.

Focal Length (mm)	Description	Focal Length (mm)	Description
+1000	double convex	-1000	double concave
+300	double convex	-200	double concave
+150	double convex	-150	double concave

### Order Information

50 mm Diameter Lens Assortment..... SE-7581

## Geometric Lens Set

OS-8466A



This is a set of three unmounted 50 mm diameter glass lenses with focal lengths of +100 mm, +200 mm, and -150 mm. These are the same lenses included in the Dynamics Track Optics Kit (OS-8471A) and the Beginning Optics System (OS-8459). They can be mounted in the Adjustable Lens Holder on page 259.

### Order Information

Geometric Lens Set..... OS-8466A

## Lens Sets

### Basic Optics Geometric Lens Set (set of 2)

(+200, +100 mm) OS-8456

### Accessory Lens Set (set of 2)

(+250, -150 mm) OS-8519



Each lens is mounted in a lens holder for protection and easy storage. The lens holder clips directly to the Basic Optics Track.

### Order Information

Basic Optics Geometric Lens Set (set of 2) ..... OS-8456

Accessory Lens Set (set of 2)..... OS-8519

## Ground Glass Lenses (set of 6)

SE-9013

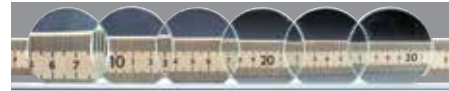

These precision ground glass lenses provide a useful range of focal lengths. Each lens has a 50 mm diameter – small enough for easy mounting, yet large enough for effective viewing. The set of six comes in a convenient storage box.

Focal Length	Description	Focal Length	Description
500 mm	concave convex	-150 mm	double concave
300 mm	plano convex	-300 mm	plano concave
150 mm	double convex	-500 mm	convex concave

### Order Information

Ground Glass Lenses (set of 6) ..... SE-9013

## Adjustable Focal Length Lens

OS-8494

Use the syringe to adjust the amount of water in the lens. Changing the curvature of the clear flexible membranes changes the focal length of the lens.

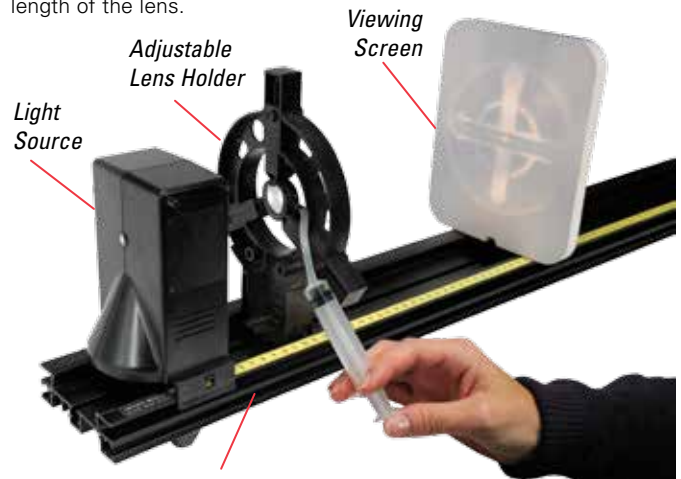

Use the Adjustable Focal Length Lens with your Basic Optics System.

See page 264 for use with Human Eye Model.

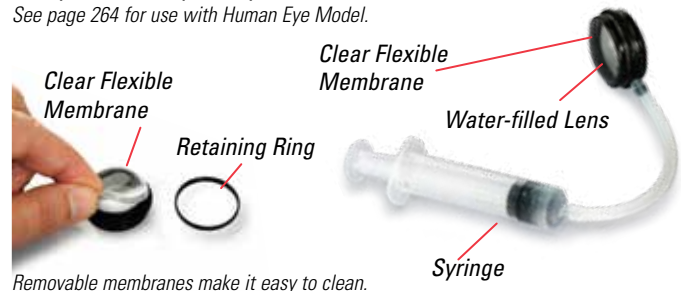

Removable membranes make it easy to clean.

### Includes

- 10 mL Syringe
- 1 ft. Silicon Tubing
- Lenses (2)

### Order Information

Adjustable Focal Length Lens ..... OS-8494

Shown in use with:

Basic Optics System ..... OS-8515C

p. 254

## Basic Optics Viewing Screen

OS-8460

This white plastic screen is used with the Basic Optics System. The screen snaps into the optics bench and the position of the screen can be read directly on the bench scale. Also fits the Dynamics Track Optics Carriages (OS-8472 on page 269) for use with a Dynamics Track.

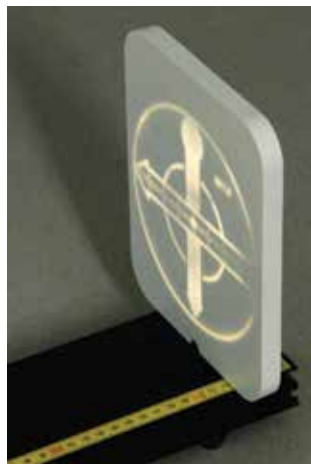

### Order Information

Basic Optics Viewing Screen .....OS-8460

## Basic Optics Spares Kit

OS-8510

*All parts are organized in a plastic case for easy storage.*



The Basic Optics Spares Kit includes many of the small parts that are sometimes lost after student use. Also includes two replacement bulbs for the Light Source. Suitable for all versions of the Basic Optics System (OS-8515).

### Includes

- 10 W bulb for Basic Optics Light Source OS-8470 or OS-8517A (2)
- 6-32 1 1/2" Screw for the Basic Optics Light Source OS-8517A (8)
- 3/8" Screw for optics accessories (6)
- 3/8" Brass thumbscrew for optics track brackets (4)
- 1/4-20 1/2" Nylon thumbscrews (8)
- 1/4-20 Square nuts (20)
- Nylon washers (6)
- 1/4-20 9/16" Round steel thumbscrews (4)
- 1/4-20 3/8" Round steel thumbscrews (4)
- 6-32 5/8" Round steel thumbscrews (6)
- 6-32 3/8" Round steel thumbscrews (4)
- 4-40 5/16" Round steel thumbscrews (4)
- 6-32 3/16" Round steel thumbscrews (4)
- Replacement rubber feet for optics bench (6)
- Replacement rubber feet for Basic Optics Light Source OS-8517A (15)
- Replacement screws for Basic Optics Light Source OS-8470 (4)
- Plastic storage box (1)

### Order Information

Spares Kit – Basic Optics .....OS-8510

## Optics Benches

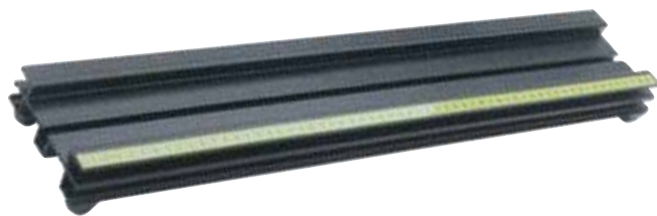

### 60 cm Optics Bench

OS-8541

This short optical bench is for experiments such as polarization and spectrophotometry.

### 120 cm Optics Bench

OS-8508

This optics bench is used for lens and mirror experiments, inverse-square law, and diffraction/interference experiments. If you want a bench longer than 120 cm, use the Optics Bench Connectors, shown below.

### Order Information

60 cm Optics Bench ..... OS-8541  
120 cm Optics Bench ..... OS-8508

## Optics Bench Rod Clamps

OS-8479

Rod Clamps are used to elevate Basic Optics benches to match the height of various light sources.



### Includes

Two Rod Clamps

### Order Information

Optics Bench Rod Clamps ..... OS-8479  
Shown in use with:  
Small Round Base with Rod ..... ME-8270

# Color

## Color Mixer

OS-8496

- ▶ Demonstrates additive color mixing
- ▶ Accessory to Basic Optics System

The Color Mixer has separate controls for each of the red, blue, and green LEDs that allow brightness to be adjusted from off to full output.

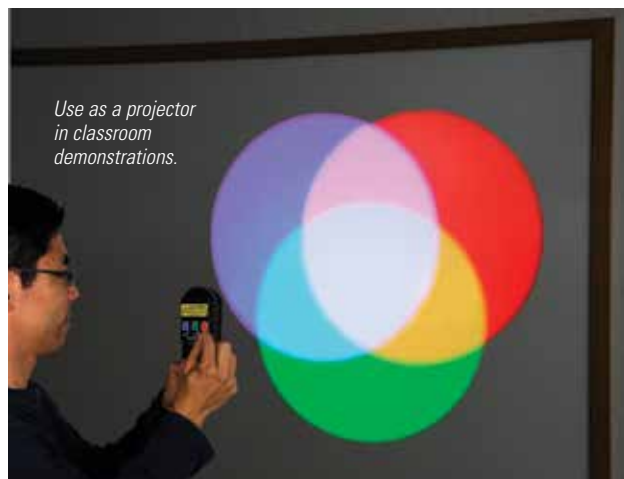

Use as a projector in classroom demonstrations.

Individually adjust the intensity of the super bright red, green, and blue LEDs.

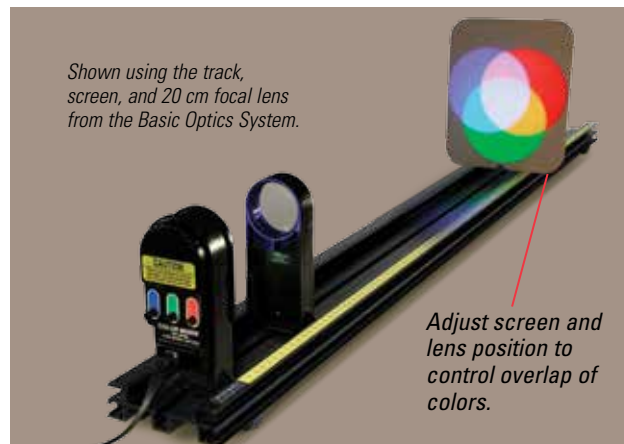

Shown using the track, screen, and 20 cm focal lens from the Basic Optics System.

Adjust screen and lens position to control overlap of colors.

Use free-standing, hand-held, or clip it directly to the Basic Optics Track.



### Includes

- Tri-color light source
- Power supply

### Order Information

Color Mixer ..... OS-8496

## Color Mixer Accessory Kit

OS-8495

- ▶ Accessory to the Color Mixer
- ▶ 7 filter cards
- ▶ 11 printed color cards
- ▶ Manual with 9 lab activities

Each card includes a graph showing its transmitted or reflected spectrum. Sets are enclosed in a clear envelope.

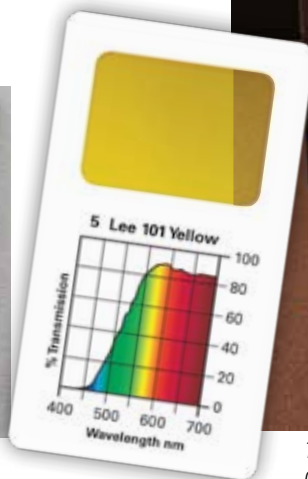

The red filter's spectral chart shows it transmits only red light. Students observe that the blue and green circles disappear and the overlapping areas of magenta, yellow, and white become red.

### Includes

- 7 Filter cards
- 11 Printed Color cards
- Manual (not shown)

### Order Information

Color Mixer Accessory Kit ..... OS-8495

## Polarizer Demonstrator

OS-9477A

Confirm Malus' Law using the Polarizer Demonstrator and a Light Sensor. The angle is read directly from the polarizer, which is marked in 5° increments. Any light source can be used, but the experiment works especially well with the Color Mixer, as shown here.

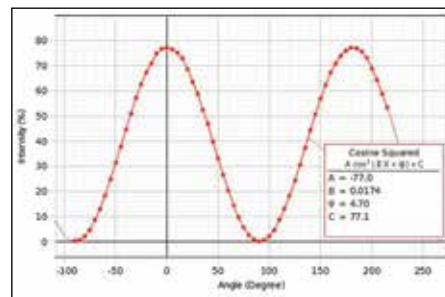
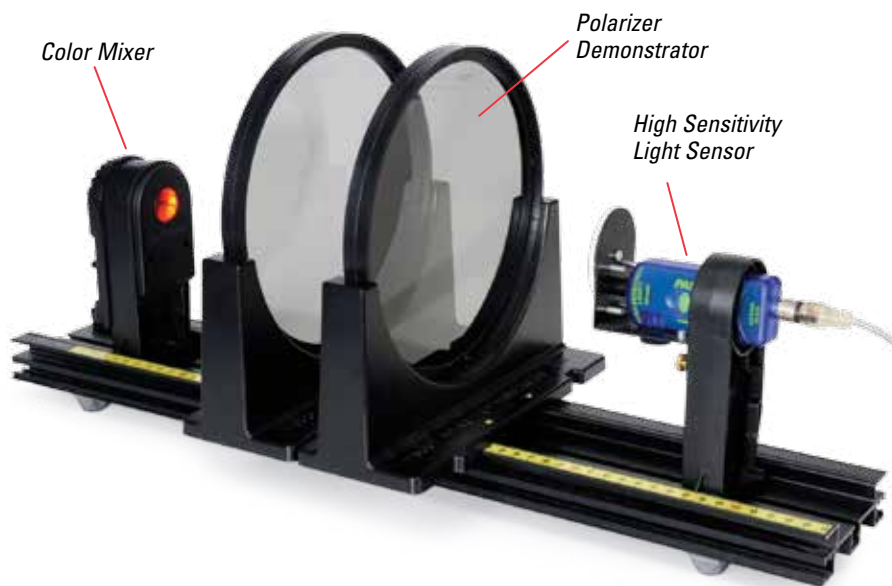

As the polarizer is rotated, the intensity of the light varies as the square of the cosine of the angle between the two polarizers.

### Order Information

Polarization Demonstrator .....	OS-9477A
<i>Shown in use with:</i>	
Optics Bench (60 cm) .....	OS-8541 p. 259
Aperture Bracket .....	OS-8534A p. 269
Color Mixer .....	OS-8496 p. 260
High Sensitivity Light Sensor .....	PS-2176 p. 49

## Polarizer Demonstrator Accessory

OS-8172

This accessory adds a central platform and diffuser to the Polarizer Demonstrator (OS-9477A). Put sugar water in one of the two supplied square glass bottles and put it on the platform between crossed polarizers. Use a desk lamp or Color Mixer (OS-8496) behind the diffuser and rotate one of the polarizers to see the sugar water change colors as the axis of polarization of different colors rotates to different angles.



*Demo with Karo® corn syrup showing wavelength dependence of optical rotation. The light source used was a compact florescent, not included.*



### Includes

- Square Glass Bottles (2)
- Metal Stand for Bottles
- Diffusion Screen

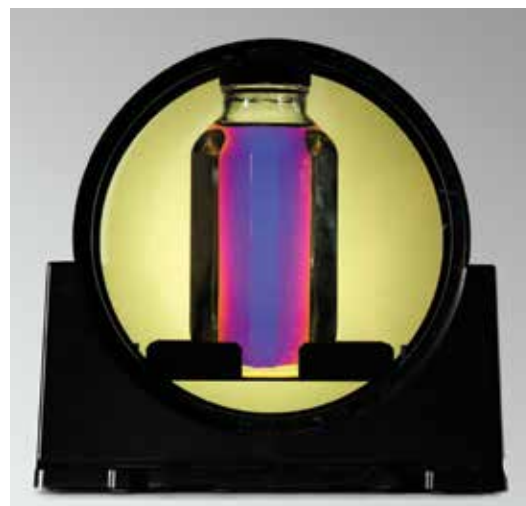

### Order Information

Polarizer Demonstrator Accessory .....	OS-8172
<i>Required:</i>	
Polarizer Demonstrator .....	OS-9477A
<i>Suggested:</i>	
Color Mixer .....	OS-8496 p. 260

# Polarization

## Polarization Analyzer

OS-8533A

Students can confirm Malus' Law of Polarization by using the Polarization Analyzer with the Basic Optics System. All components mount directly to PASCO's Basic Optics Bench OS-8541. The Rotary Motion Sensor is used to measure the angle between the two polarizing disks. The Light Sensor measures the intensity of light that passes through both polarizers.

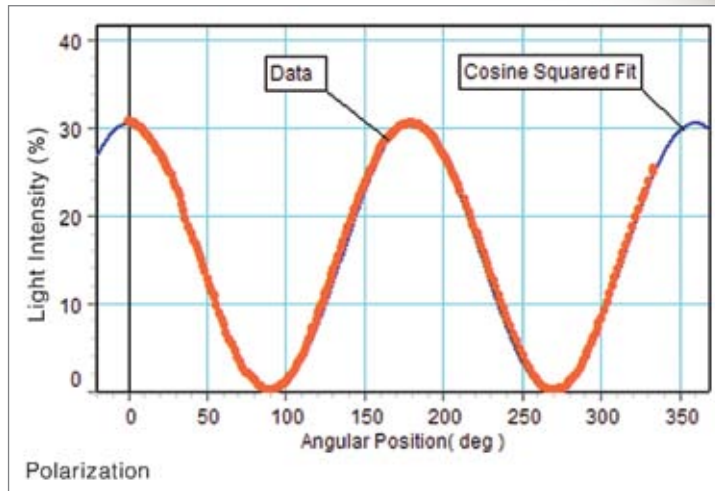
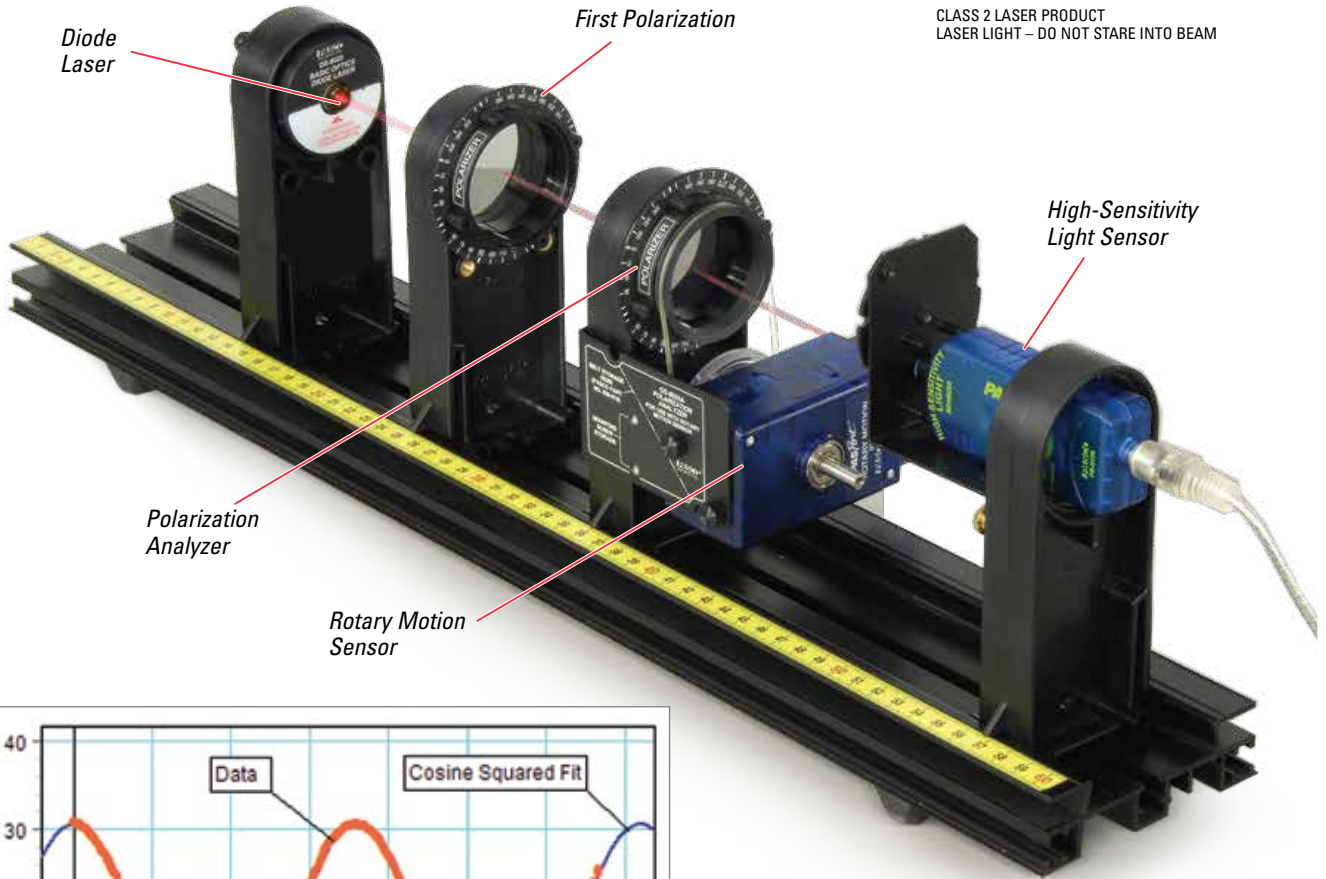

As the polarizer is rotated, the intensity of the light varies as the square of the cosine of the angle between the two polarizers.

See page 366 for complete experiment.

Shown with OS-8541, 60 cm track.

### Includes

- Polarizer Disks (2)
- Polarizer Holder
- Aperture Bracket
- Accessory Holder with Mounting Bracket
- Accessory Holder for Aperture Bracket
- Retarder Disk



### Order Information

Polarization Analyzer .....	OS-8533A
<b>Required:</b>	
Rotary Motion Sensor .....	PS-2120A
High-Sensitivity Light Sensor.....	PS-2176
Basic Optics System .....	OS-8515C
Diode Laser .....	OS-8525A

p. 25  
p. 49  
p. 254  
p. 269

## Linear Polarizer

OS-8549

This pair of rectangular polarizers are mounted in cardboard frames. The polarizing film dimensions are 3.5" x 6". Includes two polarizers.

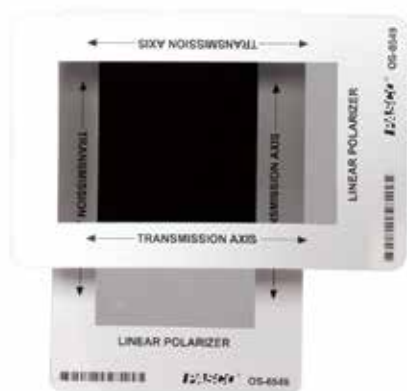

### Order Information

Linear Polarizer (2 pack).....OS-8549

## Polarizer Set

OS-8473

This accessory set includes two polarizer disks and an optics holder. Rotate the polarizers relative to one another to view the effect on light intensity.



### Order Information

Polarizer Set .....OS-8473

## Brewster's Angle Accessory

OS-8170A

- ▶ Polarization by reflection
- ▶ Brewster's Angle
- ▶ Fresnel's Law of Reflection
- ▶ Snell's Law

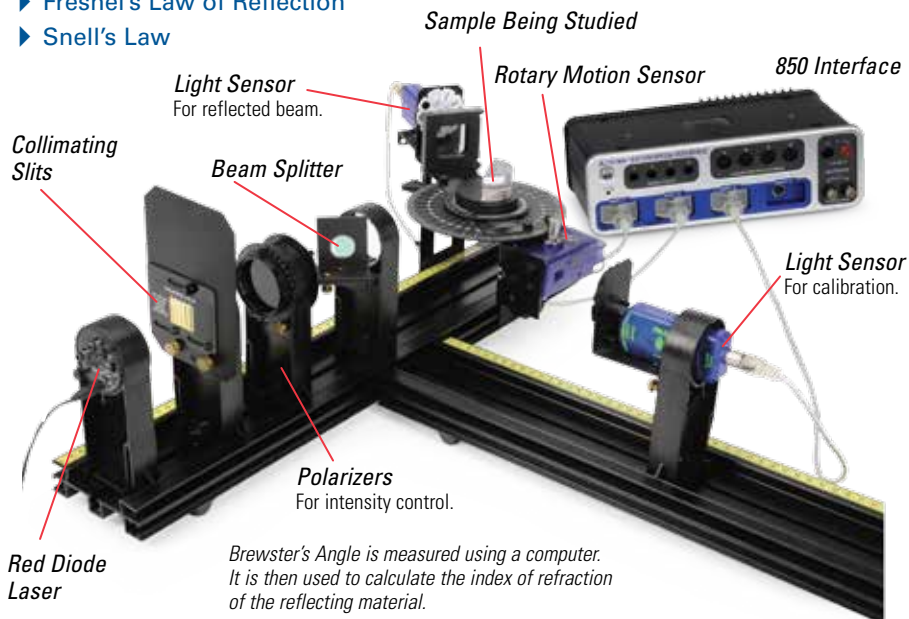

When light reflects off a nonconducting material, the reflected light is partially polarized. The amount of polarization depends on the incident angle and the index of refraction of the reflecting material. The incident angle that gives maximum polarization is called Brewster's Angle.

Light from a diode laser (wavelength = 650 nm) is reflected off the flat side of an acrylic semi-circular lens. The reflected light passes through a polarizer and is detected by a Light Sensor. The angle of incidence is measured by a Rotary Motion Sensor mounted on the Spectrophotometer table. The intensity of the reflected polarized light versus incident angle is graphed to determine the angle at which the light intensity is a minimum. This is Brewster's Angle, which is used to calculate the index of refraction of acrylic.

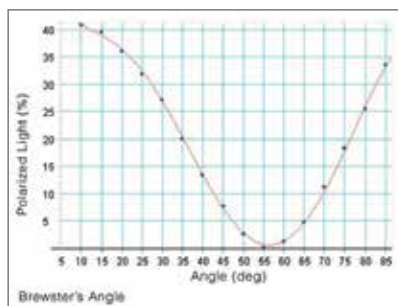

*Developed using original ideas from P.J. Ouseph, Professor of Physics at University of Louisville, KY: "Polarization of Light by Reflection and the Brewster Angle" by P.J. Ouseph, Kevin Driver, and John Conklin, Am. J. Phys. 69, 1166 (2001). This modification to the experiment was suggested by Cristian Bahrim and Wei-Tai Hsu in the American Journal of Physics article: "Precise measurement of the refractive indices for dielectrics using an improved Brewster angle method" Vol. 77, page 337 (2009).*

*The intensity (% of total reflected) of the reflected polarized light as a function of the incident angle. See Brewster's Angle Experiment on page 367.*

### Includes

- Acrylic semi-circular lens
- Lens platform
- Polarizers (2) with holder
- Analyzing polarizer
- Beam splitter



CLASS 2 LASER PRODUCT  
LASER LIGHT - DO NOT  
STARE INTO BEAM

### Order Information

Brewster's Angle Accessory ..... OS-8170A

Beam Splitter (only)..... OS-8171

For other required equipment, see the Brewster's Angle experiment EX-5544A on page 351.

# Optics of the Human Eye

## Human Eye Model

OS-8477A

- ▶ Classic eye model at an affordable price
- ▶ 3-D working model of the human eye

### Features

- ▶ **Working Model of the Human Eye:** Two lenses are used to form images on the retina. Sealed tank holds water to simulate the vitreous humor. Size and orientation of the illuminated object can be easily measured.
- ▶ **Study the Optics of Normal Vision and Vision Correction:** Use the included plastic lenses to create images for normal vision, far-sightedness, near-sightedness, and astigmatism. Additional lenses are placed in front of the eye to correct for vision problems.
- ▶ **Fixed Corneal Lens and Interchangeable Crystalline Lens:** The crystalline lens is surrounded by water (vitreous humor). By changing the crystalline lens, the eye can focus on both near and far objects.
- ▶ **Movable Retina:** Three positions to demonstrate near-sightedness, far-sightedness, and normal vision.
- ▶ **Variable Pupil Size:** Students can observe the change in brightness and clarity of the image as the pupil size is reduced.

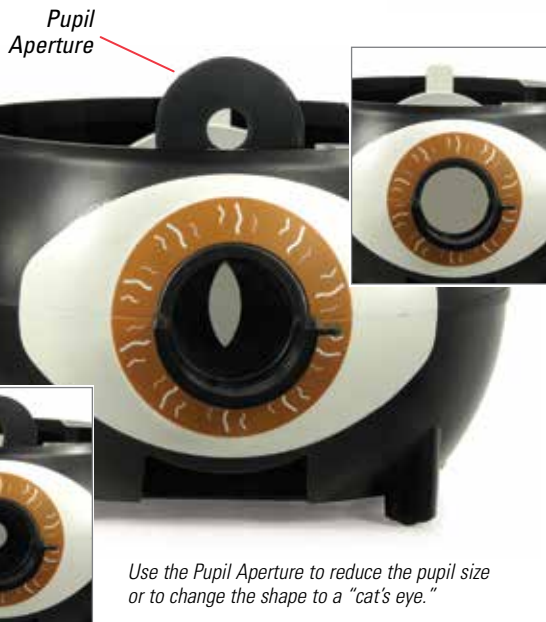

*The Eye Model can image any illuminated picture, or use with the Basic Optics System and Eye Model Bracket shown on page 277.*

### Includes

- Molded Plastic Eyeball
- Plastic Lenses (2 sets of 6)
- Pupil Aperture
- Retina Screen
- Optics Caliper (1)
- Adjustable Focal Length Lens with Syringe, Tubing, and 2 Flexible Lenses
- Experiment Manual



### Order Information

Human Eye Model.....OS-8477A

#### Recommended:

Basic Optics Light Source.....OS-8470 p. 256  
 Human Eye Replacement Set  
 (includes lenses, screen, and pupil) .....OS-8476  
 Optics Caliper (set of 5) .....OS-8468 p. 265

### Specifications

**Focal Lengths in Air of Plastic Lenses:** +62 mm (+16d), +120 mm (+8.3d), +400 mm (+2.5d), -1000 mm (-1.0d), -128 mm (-7.8d) cylindrical, +307 mm (+3.26d) cylindrical  
**Corneal Lens Focal Length in Air:** +140 mm (+7.1d)  
**Dimensions:** 15 cm x 17 cm x 10 cm high

## Eye Model Bracket

OS-8469

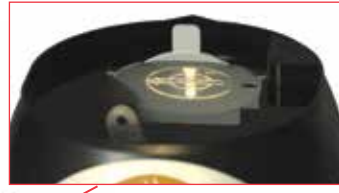
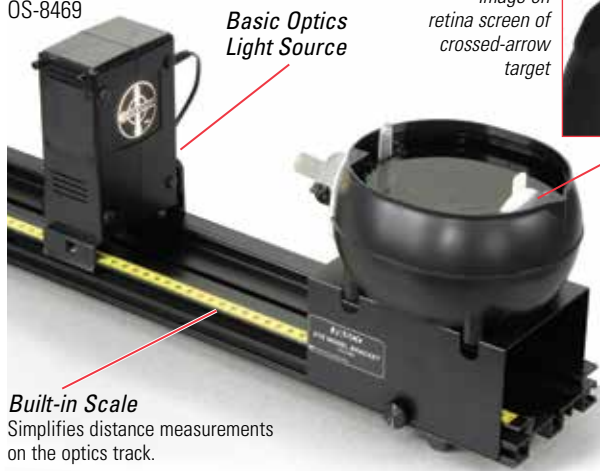

The Eye Model Bracket allows the Human Eye Model to be used with the Basic Optics System (OS-8515C). The bracket holds the Eye Model securely on the track at the correct optical height.

The illuminated crossed-arrow target on the Basic Optics Light Source makes the perfect object. Easily measure object and image distances, as well as the size of the object and image for calculations of magnification.

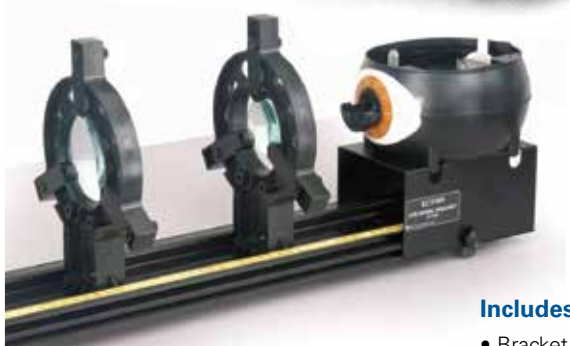

Eye Model and Bracket shown with a telescope made using two Adjustable Lens Holders (OS-8474) and accessory lenses (see page 273). Students can see the image through the telescope with their own eyes, and then place the Eye Model on the track and see the same image projected on the retina screen.

### Includes

- Bracket
- Two 1/4-20 thumb screws with nuts



### Order Information

Eye Model Bracket..... OS-8469  
 Shown in use with:  
 Basic Optics System ..... OS-8515C  
 Human Eye Model..... OS-8477A

## Optics Caliper

OS-8468

- ▶ Glow-in-the-dark tips
- ▶ Waterproof

This lightweight plastic caliper is perfect for measuring images in the dark. Simply span the object and then use a scale to measure the distance. For approximate measurements, use the built-in cm scale on the calipers.

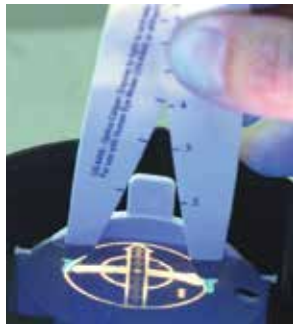

*Use the Optics Caliper to measure image sizes in the Human Eye Model. Glow-in-the-dark tips activated using a UV light source.*

### Order Information

Optics Caliper  
 (Set of 5) ..... OS-8468

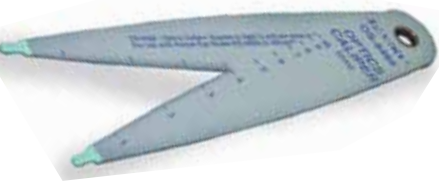

*The tips of the caliper glow in the dark. Activate with an incandescent or UV lamp.*

## Optics of the Human Eye

### Adjustable Focal Length Lens

OS-8494

Use the syringe to adjust the amount of water in the lens. Changing the curvature of the clear flexible membranes changes the focal length of the lens.

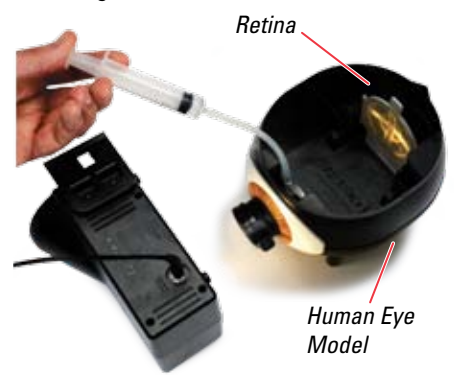

### Demonstrate accommodation:

Show how the eye lens changes focal length by changing its surface curvature.

*See page 274 for use with Basic Optics System.*

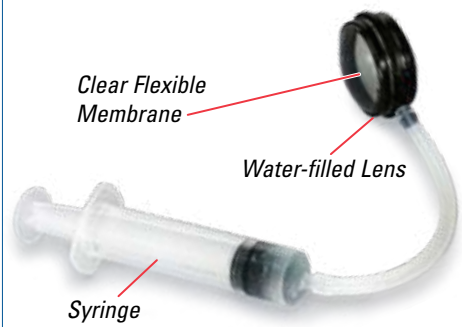

### Includes

- 10 mL Syringe
- 1 ft. Silicon Tubing
- Lenses (2)

### Order Information

Adjustable Focal Length Lens..... OS-8494

Shown in use with:  
 Human Eye Model..... OS-8477A p. 264

# Diffraction

## Sensor-Based Diffraction System

OS-8452 with Optics Bench

- ▶ Vacuum deposited chromium on glass
- ▶ Double-slit interference
- ▶ Single-slit diffraction
- ▶ Real-time intensity graphs

The Sensor-Based Diffraction System enables students to scan many diffraction and interference patterns during one lab period. They can study the differences caused by changing the slit width, slit separation, and number of slits. And, with the addition of the Green Diode Laser, they can study the difference caused by changing the wavelength.



Scanning with the Linear Translator (on page 269): In this unique scanning system, the diffraction pattern is scanned using a light sensor attached to a Rotary Motion Sensor. As the wheel on the Rotary Motion Sensor is rotated by hand, the Rotary Motion Sensor moves along a gear rack (called the Linear Translator). Students make the association between the diffraction pattern they see and the real-time graph of the light intensity versus position.

CLASS 2 LASER PRODUCT  
LASER LIGHT – DO NOT STARE INTO BEAM

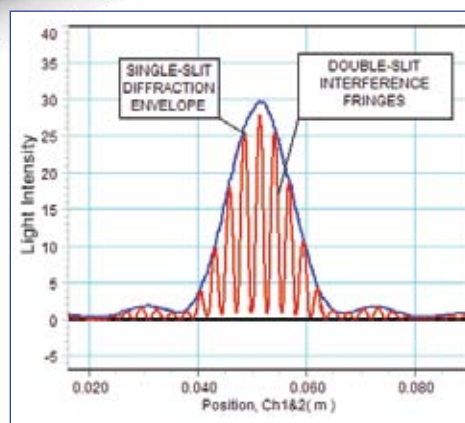
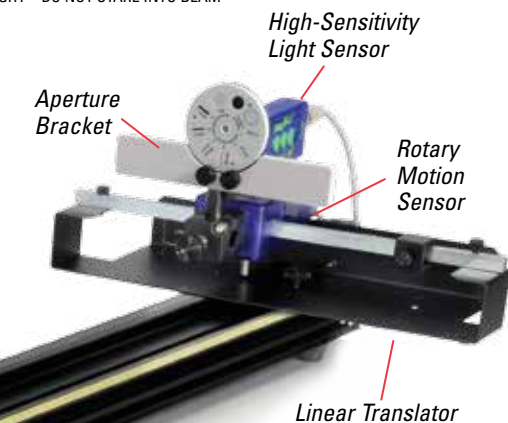

Computer scan of a single-slit and double-slit having the same slit width.

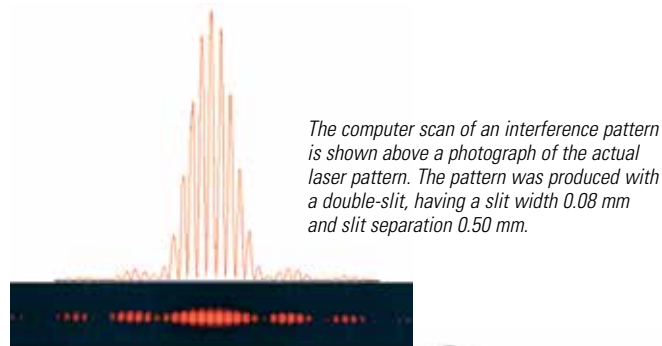

The computer scan of an interference pattern is shown above a photograph of the actual laser pattern. The pattern was produced with a double-slit, having a slit width 0.08 mm and slit separation 0.50 mm.

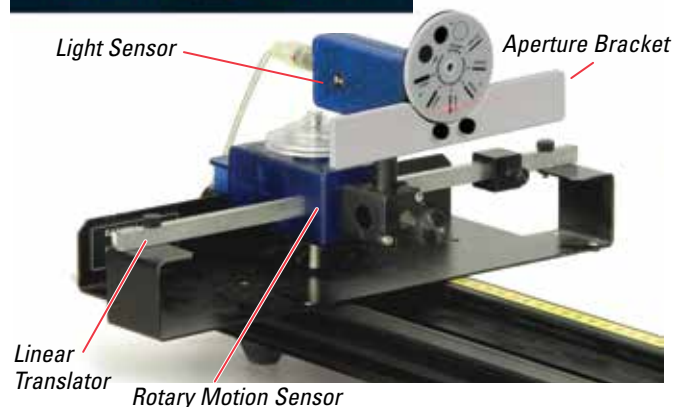

### Includes

- Red Diode Laser (OS-8525A)
- Linear Translator (OS-8535)
- Aperture Bracket (OS-8534A)
- Optics Bench (OS-8508)
- High Precision Diffraction Slit Set (OS-8453)



For components and accessories, see pages 268-269.

### Order Information

Sensor-Based Diffraction (with Optics Bench).....	OS-8452
<i>Required for use with ScienceWorkshop:</i>	
Light Sensor.....	CI-6504A
Rotary Motion Sensor.....	CI-6538
<i>Required for use with PASPORT:</i>	
High Sensitivity Light Sensor.....	PS-2176
Rotary Motion Sensor.....	PS-2120A
<i>Recommended:</i>	
Green Diode Laser.....	OS-8458B

## Diffraction Optics Kit

OS-8531A

Add this kit to the Basic Optics System to allow the investigation of a wide variety of diffraction slit patterns. The slits are constructed using vacuum deposited chromium on glass. The following patterns are included:

- ▶ Single Slit (four variations)
- ▶ Variable Width Single Slit
- ▶ Double Slit (four variations)
- ▶ Multiple Slit (3,4,5)
- ▶ Single Slit/Double Slit Comparison
- ▶ Variable Spacing Double Slit

### Slit Accessory

Snaps into position on the bench for automatic slit alignment with laser. Rotate disk to select a different pattern.



Single Slit Pattern ( $a = 0.04 \text{ mm}$ )



Double Slit Pattern ( $a = 0.08 \text{ m}$ ,  $b = 0.05 \text{ mm}$ )

Red Diode Laser



CLASS 2 LASER PRODUCT  
LASER LIGHT – DO NOT  
STARE INTO BEAM



4-Slit Pattern ( $a = 0.04 \text{ mm}$ ,  $d = 0.125 \text{ mm}$ )



Single/Double Slit Comparison

### Easy Laser Alignment.

The laser beam can be aimed through the slits using two thumb screws. Once the beam is aligned, either the laser or the slits can be removed from the optics bench and returned to the bench without re-aligning the beam.



### Change Slits in the Dark Without Re-aligning Everything.

The slit wheels eliminate the frustration of trying to change the slits in a darkened room. Simply rotate to the next positive click to lock a different slit into position. The alignment of the disk only has to be done once. After that, all the slits on that wheel will be aligned.

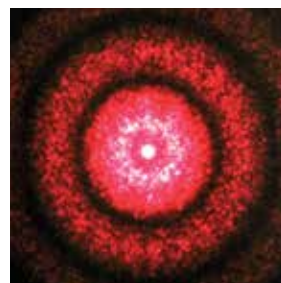

Circular Diffraction Pattern

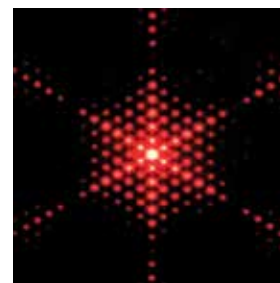

Hex diffraction Pattern

## Optics Caliper

OS-8468

This lightweight plastic caliper is perfect for measuring interference and diffraction patterns in the dark.

Glow-in-the-dark tips are activated using an incandescent or UV lamp. See page 277 for more information.



### Order Information

Optics Caliper (Set of 5)..... OS-8468

### Includes

- Red Diode Laser (OS-8525A)
- High Precision Diffraction Slit Set (OS-8453)



For components and accessories, see pages 268-269.

### Order Information

Diffraction Optics Kit.....OS-8531A

#### Required:

120 cm Optics Bench .....OS-8508

Basic Optics Viewing Screen .....OS-8460

#### Recommended:

Green Diode Laser.....OS-8458B

p. 269

# Diffraction Components

## High-Precision Diffraction Slits

OS-8453

- ▶ Vacuum deposited chromium on glass
- ▶ Single-slit and double-slit wheels

OS-8453 includes two slit wheels with holders designed to match the height of the slits to the height of the diode laser. All components clip directly to the Optics Bench from the Basic Optics System OS-8515C. The slit wheels eliminate the frustration of trying to change the slits in a darkened room. To change the slit being illuminated by the laser, the slit wheel is simply rotated to the next positive click to lock another slit into position.

Shown in use with the red OS-8525A and green OS-8458 Diode Lasers.

Simply rotate the wheel to select the desired slit. Each position locks into place, making it easy to use, even in the dark.



CLASS 2 LASER PRODUCT  
LASER LIGHT – DO NOT  
STARE INTO BEAM

**The Single-Slit Wheel** includes four single slits of different widths, two circular apertures, one line/slit comparison, one opaque line, a variable width slit, and four patterns.

**The Multiple-Slit Wheel** includes four double slits, a set of four multiple slits having the same slit width and separation (2, 3, 4, and 5 slits), four slit comparisons, and a variable double slit.

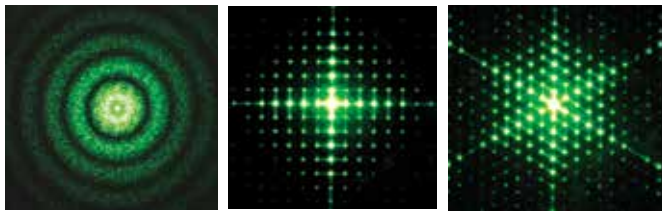
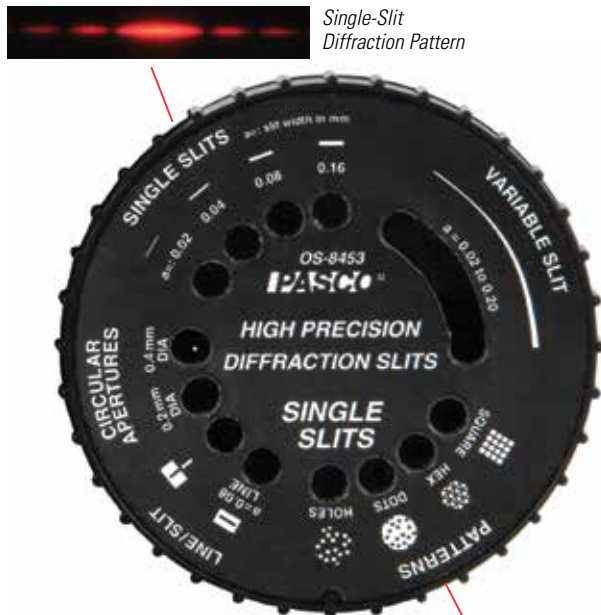

The Circular Diffraction pattern has the same dimensions for both the dots and the holes.  
The diffraction geometry represents the structure of the Square and Hex pattern.

- Includes**
- Single-Slit wheel with Holder
  - Multiple-Slit wheel with Holder

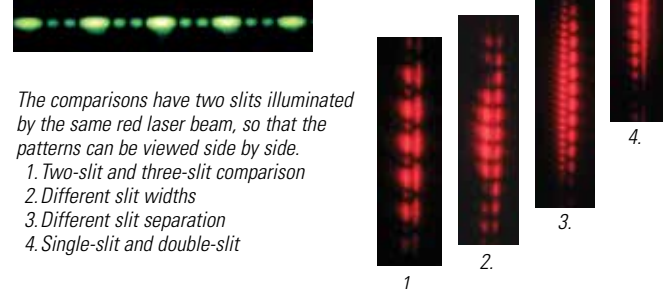
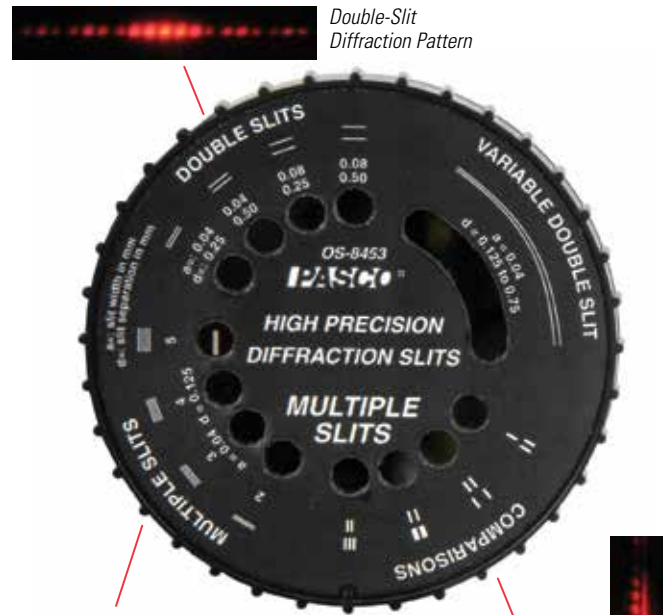

The comparisons have two slits illuminated by the same red laser beam, so that the patterns can be viewed side by side.  
1. Two-slit and three-slit comparison  
2. Different slit widths  
3. Different slit separation  
4. Single-slit and double-slit

**Order Information**

High Precision Diffraction Slits .....	OS-8453	
<i>Recommended:</i>		
Basic Optics System .....	OS-8515C	p. 254
Diode Laser – Red .....	OS-8525A	p. 269
Diode Laser – Green .....	OS-8458B	p. 269

## Diode Laser – Basic Optics

OS-8525A (Red)

OS-8458B (Green)

These unique diode lasers take the frustration out of aligning the laser beam with the diffraction slits. With both lasers, you can demonstrate the effect of changing wavelength on the diffraction and interference patterns.

A red laser beam was passed through a double slit. Then the Red Diode Laser was replaced by the Green Diode Laser by simply pulling the Red Laser off the optics track and clipping the Green Laser into its place. The recorded patterns from red and green lasers show clearly that the longer wavelength (red) is spread out more than the green.

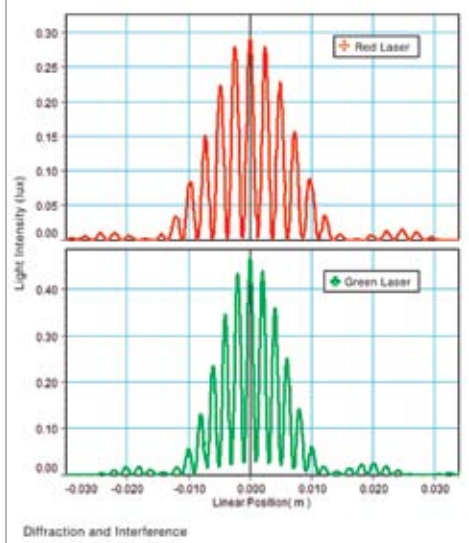
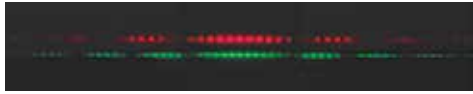

Laser off the optics track and clipping the Green Laser into its place. The recorded patterns from red and green lasers show clearly that the longer wavelength (red) is spread out more than the green.



The horizontal and vertical positions of the beam can be adjusted by turning the thumb screws on the back of the laser.



Demonstrate the effect of changing wavelength on the diffraction and interference patterns.

CLASS 2 LASER PRODUCT  
LASER LIGHT – DO NOT STARE INTO BEAM

### Specifications

**Output Power:** <1 mW

**Wavelength:** 650 nm (OS-8525A) 515 nm (OS-8458A)

**Power Supply:** 9-V adapter (included)

### Order Information

Diode Laser – Red .....OS-8525A

Diode Laser – Green .....OS-8458B

## Linear Translator

OS-8535A



The Linear Translator transforms a Rotary Motion Sensor into a linear motion device. The toothed rack of the Linear Translator fits into the slot in the side of the Rotary Motion Sensor. As the Rotary Motion Sensor pulley is rotated by hand, the Rotary Motion Sensor moves along the rack. *Rotary Motion Sensors not included.*

### Specifications

**Resolution for Rotary Motion Sensor:**  
0.055 mm (CI-6538); 0.020 mm (PS-2120)

**Maximum Travel:** 20 cm

### Order Information

Linear Translator .....OS-8535A

*Recommended:*

Rotary Motion Sensor ..... p. 25

## Aperture Bracket

OS-8534A

The Aperture Bracket acts as a mask for a light sensor. The wheel is rotated to select different size slits, defining the spatial resolution. Narrow slits are used to scan diffraction patterns having fine detail. Wider slits are used to let in more light when scanning dimmer patterns. The diffuser selection is used for inverse square law experiments.

### Specifications

**Six Slits:** From 0.1 mm to 1.5 mm width

**Open Aperture:**  
No reduction in intensity  
10% transmittance diffuser

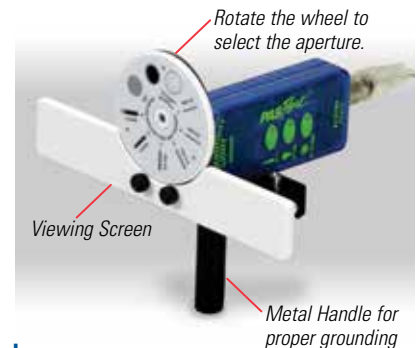

### Includes

- Aperture Bracket with Screen
- Metal Handle
- Accessory Holder

### Order Information

Aperture Bracket ..... OS-8534A

# Dynamics Track Optics

## Dynamics Track Optics Kit

0S-8471A

- ▶ Turns your dynamics track into an optics bench
- ▶ Use with 1.2 or 2.2 m Dynamics Tracks and PAStrack
- ▶ Expandable with Basic Optics System components



The PASCO Dynamics Track Optics Kit includes specially designed slides (carriages) that snap on the dynamics track. PASCO Basic Optics components attach directly to the carriage for positioning anywhere on the track.

Choose from a wide range of optics components to expand your system. See pages 272-285 for more components.



### Includes

- Basic Optics Light Source
- Two Adjustable Lens/Mirror Holders +100 mm, +200 mm, and -150 mm Focal Length Lenses
- Viewing Screen
- Three Optics Carriages

### Order Information

Dynamics Track Optics Kit .....	0S-8471A
<i>Required:</i>	
Dynamics Track 1.2 m .....	ME-9493
or	
Dynamics Track 2.2 m .....	ME-9779
or	
PAStrack.....	ME-6960



## Typical Experiments

1. Focal Length and Magnification of a Thin Lens
2. Telescope
3. Microscope
4. Shadows
5. Virtual Images



To see the experiments, type the product number into the search box at [www.pasco.com](http://www.pasco.com) and download the manual.

## Dynamics Track Optics Carriages

0S-8472

The Dynamics Track Optics Carriages are designed to snap onto the PASCO Dynamics Track. Basic Optics components attach directly to the carriages for positioning anywhere on the track.

### Includes

- Carriages (3)



### Order Information

Dynamics Track Optics Carriages.....	0S-8472
--------------------------------------	---------

# Light, Color, and Optics

## Curriculum

### Light, Color, and Optics Teacher Resources

EP-6481

- ▶ 12 lessons
- ▶ 5 interactive simulations
- ▶ 8 interactive equations
- ▶ 12 slide presentations
- ▶ 12 lesson plans
- ▶ 12 student assignments
- ▶ Requires Light, Color, and Optics Kit

Introduce your students to the science and technology of light including reflection, refraction, color, intensity, lenses, mirrors, real and virtual images, human vision, digital imaging, and the quantum theory of light. For more information, visit [pasco.com](http://pasco.com)

## Equipment

### Light, Color, and Optics Kit

EP-3558

The Light, Color, and Optics Kit is a complete laboratory for learning about light, color, and optical technology. Three 50-mm optics snap onto the track and slide easily. The light source makes a perfect illuminated “object” for optics experiments, and the fixed spacing of the colored LEDs makes it easy to observe and measure image properties such as magnification, inversion, and brightness.

#### Includes

- 1.2 m Aluminum track
- 50 mm optics mounts (3)
- Rechargeable light source
- AC adapter/charger
- Refraction tank
- Triangular prism
- Phosphorescent plastic
- 50 mm convex lens - 10 cm f.l.
- 50 mm convex lens - 20 cm f.l.
- 50 mm convex lens - 50 cm f.l.
- 50 mm concave lens - 20 cm f.l.
- 50 mm convex mirror - 20 cm f.l.
- 50 mm concave mirror - 50 cm f.l.
- 50 mm screen
- 50 mm diffraction grating
- Eyeglasses



*New lens holders mount to PASCO tracks.*



#### Order Information

Light, Color, and Optics Teacher Resources.....	EP-6481
Light, Color, and Optics Kit.....	EP-3558

# Spectrometer

## PASCO Wireless Spectrometer

PS-2600

**Now includes Spectrometry 2.0 functionality!**

- ▶ Measure intensity, absorbance, transmittance, and fluorescence.
- ▶ Works on all computing platforms
- ▶ Bluetooth™ or USB connectivity
- ▶ Includes free award-winning spectrometry software

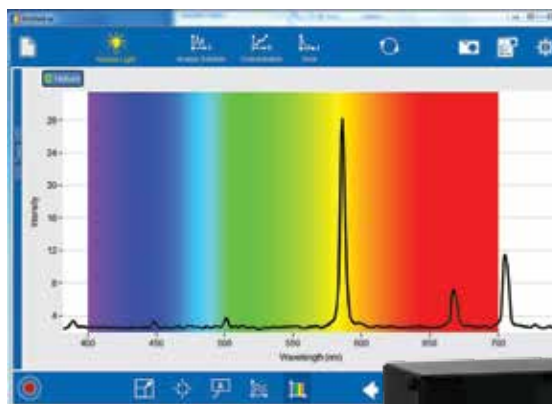

Helium Spectrum

Shown using the optional Fiber Optics Cable (shown below).



### Specifications

- Bluetooth and USB** connectivity
- Resolution:** 2–3 nm FWHM
- Range:** 380–950 nm
- Wavelengths:** 2 fluorescence excitation wavelengths at 405 nm and 500 nm
- Light Source:** LED-boosted tungsten

### You can perform these labs with the Wireless Spectrometer:

- ▶ Emission Spectra of Light
- ▶ Absorbance Spectra
- ▶ Beer's Law
- ▶ Kinetics
- ▶ Fluorescence



### Fiber Optic Cable

PS-2601  
Required for External Light Sources



#### Order Information

Fiber Optic Cable.....PS-2601

### Includes

- PASCO Spectrometer
- 10 cuvettes
- Spectrometry software (shown on opposite page)

#### Order Information

PASCO Spectrometer..... PS-2600

## PASCO's Free Spectrometry Software Puts Learning First

PASCO's award-winning software for iOS, Android™ Computers, and Chromebooks\*

- ▶ Designed by teachers
- ▶ Specialized software specifically targets spectrometry activities
- ▶ Program guides students through the four common types of spectrometer uses
- ▶ Calibration routine is made obvious

The four specially targeted activities are:

1. Analyze light sources with the optional fiber optics cable.
2. Analyze the absorbance, transmittance, and fluorescence of colored solutions.
3. After the analysis wavelength is set, you can easily create calibration curves and determine the unknown concentration
4. Observe the kinetics of a reaction involving a colored solution. Easily create the required graphs (ln(x), 1/x) to determine the order of the reactants.

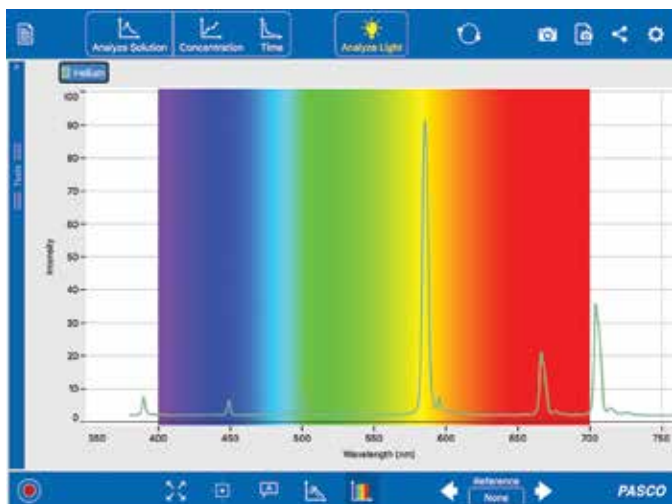

Analyze light sources with the optional Fiber Optic Cable.

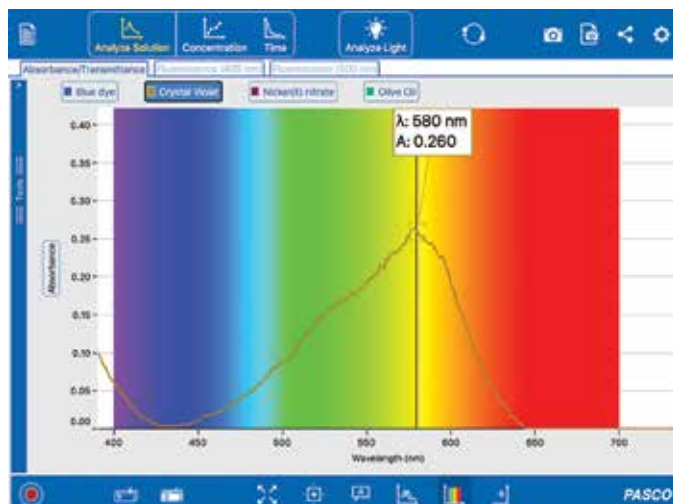

Full visible spectrum analysis of solutions

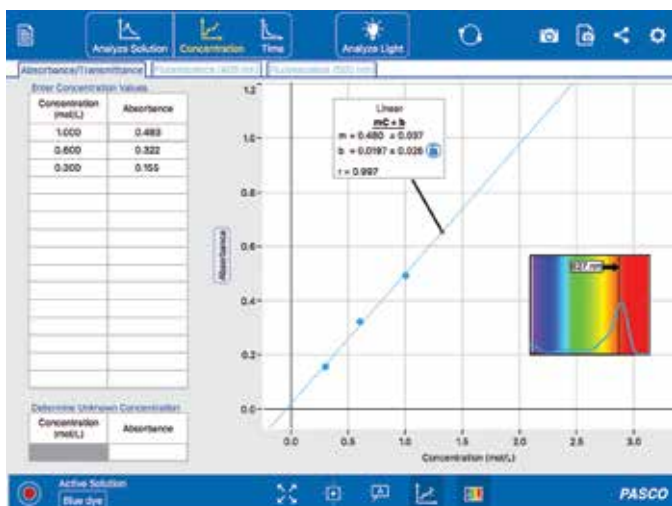

Create Beer's Law plots to relate absorbance and concentration.

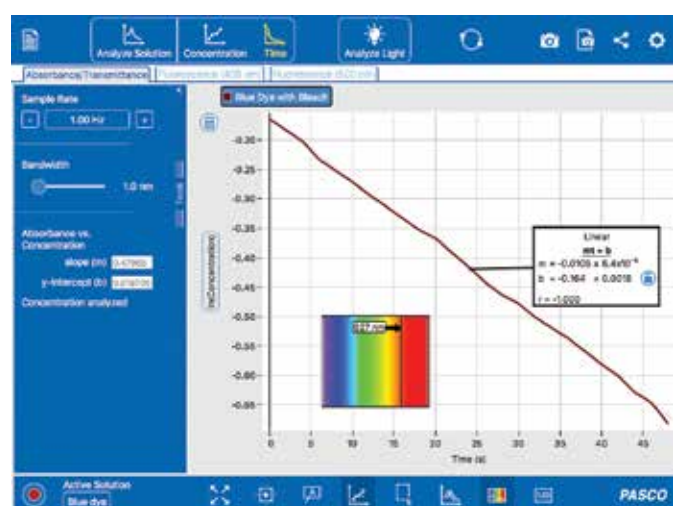

Quickly plot calculations of Concentrations vs. Time to determine the order of the reaction.

The Wireless Spectrometer comes with **PASCO's FREE award-winning Spectrometry software.**

- ▶ PC and Mac versions included with purchase.
- ▶ FREE for iOS, Android™, and Chrome™
- ▶ Designed specifically for introductory spectrometry experiments.

Download at [pasco.com/downloads](http://pasco.com/downloads)

\*Our list of compatible Chromebooks is expanding rapidly. Check [pasco.com/compatibility](http://pasco.com/compatibility) for the latest updates.

# Spectrophotometer

## Educational Spectrophotometer System

OS-8450 (PASPORT)

OS-8539 (ScienceWorkshop)

## Educational Spectrophotometer Accessory Kit

OS-8537

- ▶ Analyze and graph spectral lines
- ▶ Explore relationships between angle, wavelength, and intensity
- ▶ Versatile and inexpensive

PASCO's Educational Spectrophotometer teaches basic optical principles and allows quantitative measurements rivaling those of more expensive units.

When the Spectrophotometer is used with PASCO's Capstone™ Software, students can explore the relationship between angle, wavelength, and intensity, and graph the spectral lines from discharge tubes. Lines from mercury, sodium, helium, neon, krypton, and argon can be plotted. Even the lines of the Balmer series in hydrogen can be detected.

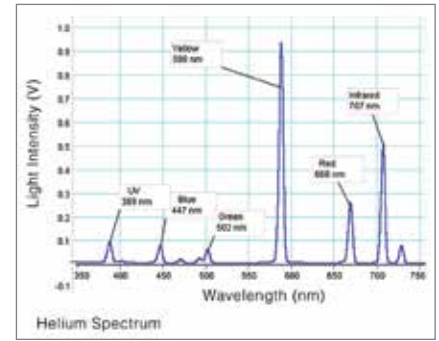
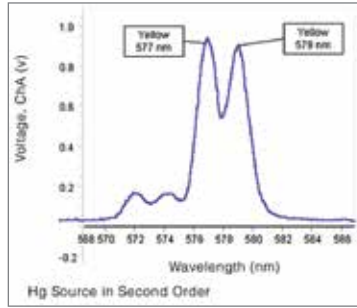

## Typical Spectrum Graphs

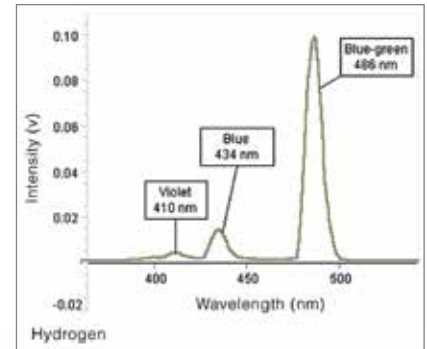
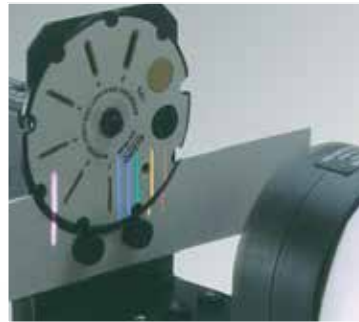

**Collimating Slits**  
Set of five slits ranging from 0.1-1.5 mm

**Collimating Lens**  
50 mm dia. coated lens

**Focusing Lens**  
50 mm dia. coated lens

**Diffraction Grating**  
High-quality, 600 lines/mm grating strongly blazed in the first order

**Rotating Light Sensor Arm and Table**

**Aperture Bracket**  
When used with a 600 lines/mm grating, permits resolution to 1.5 nm. Metal handle ensures proper grounding, reducing noise for very low light levels.

**High-Sensitivity Light Sensor**  
Spectral response: 320-1100 nm

**Rotary Motion Sensor**  
Sensor is coupled to the rotating table via a friction rim drive. Resolves to 15 arc seconds.



## Educational Spectrophotometer Components

Teachers who already own a PASCO Interface and the Basic Optics System OS-8515C should purchase the Accessory Kit OS-8537 and any additional equipment needed from the list below.

### The Spectrophotometer System includes

1. Optics Bench (60 cm) OS-8541
2. Rotary Motion Sensor
3. High-Sensitivity Light Sensor CI-6604
4. Aperture Bracket OS-8534A
5. Spectrophotometer Table
6. Rotating Arm
7. Collimating Slits and Lens
8. Focusing Lens
9. Diffraction Grating and Holder
10. Optics Bench Rod Clamps (2) ME-9836

ScienceWorkshop  
**OS-8539**

CI-6538  
CI-6604

PASPORT  
**OS-8450**

PS-2120A  
PS-2176

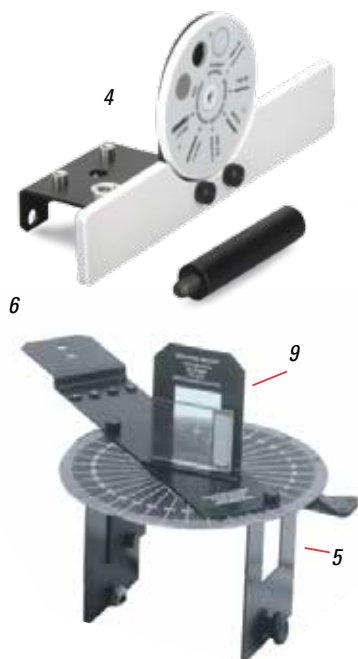

### The Spectrophotometer Accessory Kit (OS-8537) includes

5. Spectrophotometer Table
6. Rotating Arm
7. Collimating Slits and Lens
8. Focusing Lens
9. Diffraction Grating and Holder
10. Optics Bench Rod Clamps (2) ME-9836

*Note: The open design of this spectrophotometer accessory is ideal for education. It is not intended for industrial or research applications.*

#### Order Information

Educational Spectrophotometer System  
PASPORT ..... OS-8450  
ScienceWorkshop ..... OS-8539  
Educational Spectrophotometer  
Accessory Kit ..... OS-8537

*For use with PASPORT Sensors, see the Atomic Spectra experiment EX-5546 on page 369.*

*For adjusting height of optics bench to your light source:*  
Round Base with Rod ..... ME-8270

p. 177

### High-Quality Grating

600 lines/mm SE-9358

The 600 lines/mm grating is strongly blazed in the first order. It has excellent resolving power and produces bright, sharp spectral lines for spectrometer labs or for projecting spectra in lecture demonstrations.



#### Order Information

High-Quality Grating 600 lines ..... SE-9358

# Spectrophotometer

## Prism Spectrophotometer Kit

OS-8544

- ▶ High-quality prism
- ▶ Light sensor senses into infrared
- ▶ Blackbody light source

Prism Spectrophotometer Kit mounted on the Spectrophotometer System

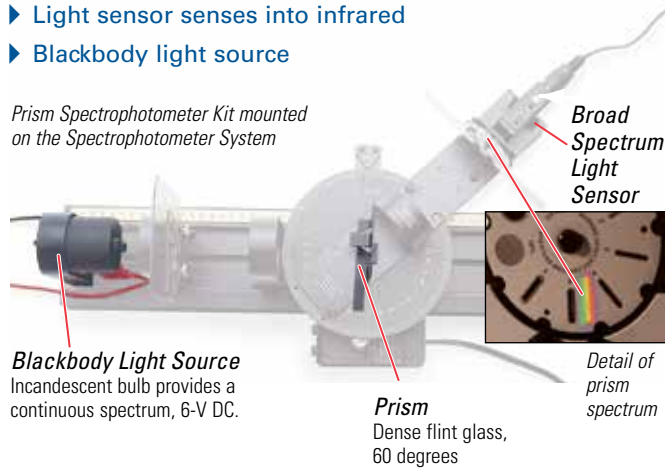

**Blackbody Light Source**  
Incandescent bulb provides a continuous spectrum, 6-V DC.

**Prism**  
Dense flint glass, 60 degrees

**Detail of prism spectrum**

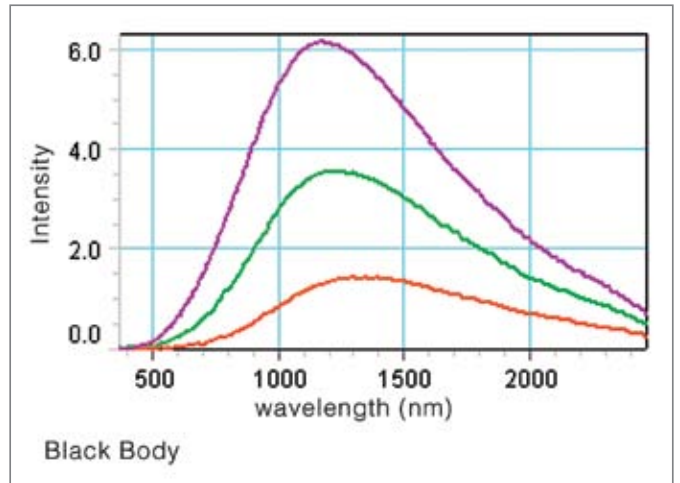

The classic textbook diagram of the intensity versus wavelength blackbody curves can be produced with real data. In this graph, the peak wavelength in the blackbody curve shifts as the source temperature is lowered.

Using this prism spectrophotometer, students can scan the spectrum of a “blackbody”; plot the intensity versus wavelength, and change the temperature of the blackbody to see the shift in the peak wavelength.

This spectrophotometer uses a prism to disperse the light instead of a diffraction grating. This allows the infrared to be seen without overlapping the second order visible spectral lines. The sensor has a linear response to all wavelengths within its range, so the actual intensity of the light in the blackbody spectrum is detected. Designed to be used with the Spectrophotometer System described on pages 288-289.



**Includes**

- Prism
- Mount
- IR Filter
- Blackbody Light Source (OS-8542)

**See Blackbody Radiation Experiment on page 327.**

**Order Information**

Prism Spectrophotometer Kit .....	OS-8544	
<i>OR components of the system may be ordered separately:</i>		
Blackbody Light Source .....	OS-8542	
Mounted Prism .....	OS-8543	
<i>Required for experiment:</i>		
Broad Spectrum Light Sensor .....	PS-2150	p. 49
Spectrophotometer System .....	OS-8539	
850 Universal Interface .....		p. 12
PASCO Capstone .....		pp. 18-20
<i>Replacement Supplies:</i>		
Replacement Bulbs (10 pack) .....	SE-8509	

## Student Spectrometer

SP-9268A

- ▶ Wide aperture optics
- ▶ Precision vernier: resolves one minute of arc
- ▶ Durable and precise

### Collimator

High-quality, large-aperture optics with a 6 mm long slit of adjustable width. The collimator can be independently focused, leveled, and aligned.



**Telescope**  
High-quality, large-aperture optics plus a 15x Ramsden eyepiece with a crosshair graticule. The telescope can be independently focused and aligned.

**Custom Prism/  
Grating Table**  
Threaded holes and engraved reference lines for accurate component placement

**Vernier  
Scale**  
For precision measurements

**Precision-Ground  
Bearings**  
The main bearings are ground as a single unit, so the movement is exceptionally smooth with virtually no backlash. This is essential for precise positioning.

**Durable  
Construction**  
Heavy aluminum castings provide a stable base for delicate measurements and ensure long-term durability.

**Magnifier**  
For reading the Vernier Scale

**Dense Flint  
Glass Prism  
with Holder**

## Features

- ▶ **Resolution to 1 Minute of Arc:** The 127 mm diameter, precision-engraved degree plate is complemented by two precision-engraved verniers, one on each side of the instrument for convenient reading.
- ▶ **Wider Aperture Optics:** 32 mm wide apertures on the telescope and collimator provide more light for brighter and sharper images.
- ▶ **Rack and Pinion Focusing:** On both the telescope and the collimator, so focusing is easier and more precise.
- ▶ **Rotating Table:** For greater flexibility in measurements. Turn the table by hand for coarse adjustments. Use the fine lead screw for delicate adjustments.



The Vernier Scale resolves angle measurements within 1 minute of arc.

## Order Information

Student Spectrometer..... SP-9268A  
**Recommended:**  
 Spectral Light Sources ..... p. 278

# Spectral Light Sources

## Mercury Light Source

SE-6608

This bright mercury light source is perfect for studying spectra with the Educational Spectrophotometer (OS-8539). It is also used with the Photoelectric Effect experiment (SE-6609 and EX-5549A) and mounts on the extruded track in that experiment.



### Includes

- Mercury Light Source Housing
- Power Supply
- Mercury Lamp (SE-6597)

### Order Information

Mercury Light Source .....SE-6608  
 Replacement Supplies:  
 Replacement Mercury Lamp .....SE-6597

## Spectral Tube Power Supply and Mount

SE-9460

This system is easy-to-use and inexpensive, with a variety of safety features that make it suitable for beginning labs. Mount any of the eight different spectral tubes into the power supply and turn it on. The 26 cm long tubes are capillary-thin over the middle 10 cm, providing sharp, bright spectra.

### Features

- ▶ **Student Safety:**  
 The tubes mount from the front of the supply and snap into molded sockets that fully enclose the conductive ends. The all-metal case is electrically grounded.
- ▶ **Spectral Tube Safety:**  
 A current limiting transformer protects the tubes. A protective shield also helps safeguard the tubes, while blocking unwanted ambient light for clear viewing.
- ▶ **Power Requirements:**  
 115/220 VAC, 50/60 Hz.



Power Supply and Mount

### Order Information

Spectral Tube Power Supply ..... SE-9460

## Spectral Tubes

- ▶ Argon
- ▶ Carbon Dioxide
- ▶ Helium
- ▶ Hydrogen
- ▶ Krypton
- ▶ Mercury
- ▶ Neon
- ▶ Water Vapor

These spectral tubes are designed for use in the Spectral Tube Power Supply and Mount at the left.



### Order Information

Spectral Tubes:

Argon.....	SE-9463
Carbon Dioxide.....	SE-9464
Helium.....	SE-9462
Hydrogen.....	SE-9461
Krypton.....	SE-9465
Mercury.....	SE-9466
Neon.....	SE-9467
Water Vapor.....	SE-9468

## Diode Laser – Basic Optics

OS-8525A (Red) OS-8458B (Green)

These diode lasers fit on the Basic Optics Benches (OS-8505 and OS-8541) and the Dynamics Track Optics Carriage (OS-8472).



CLASS 2 LASER PRODUCT  
LASER LIGHT – DO NOT STARE INTO BEAM

### Specifications

**Output Power:** <1 mW  
**Wavelength:** 650 nm (OS-8525A)  
 515 nm (OS-8458B)  
**Power Supply:** 9-V adapter (included)

### Order Information

Diode Laser – Red ..... OS-8525A  
 Diode Laser – Green ..... OS-8458B

## Laser Pointers

SE-9716C (Red)  
 SE-8805A (Green)

- ▶ Push-button switch
- ▶ Inexpensive



CLASS II LASER PRODUCT  
LASER RADIATION – AVOID DIRECT EYE EXPOSURE

### Specifications

**Source:** Laser diode  
**Power:** 5 mW max. (class II)  
**Wavelength:** 645 nm (red pointer)  
 532 nm (green pointer)  
**Battery:** Alkaline AAA (2 included)  
**Dimensions:** 143 mm x 12.7 mm (red pointer)  
 151 mm x 13.5 mm (green pointer)

### Order Information

Red Laser Pointer .....SE-9716C  
 Green Laser Pointer .....SE-8805A

## Mini Laser w/Bracket

OS-8514



Shown  
mounted on a  
PASCO Laser  
Alignment Bench  
(see below).

CLASS II LASER PRODUCT  
LASER RADIATION – DO NOT STARE INTO BEAM OR  
VIEW DIRECTLY WITH OPTICAL INSTRUMENTS

This 0.5 mW Helium Neon Laser is ideal for use with the PASCO Advanced Optics System. It includes a mounting bracket that attaches to the PASCO magnetic optics bench and permits adjustment of the laser beam in the x and y axes.

The aperture has a 15.8 mm (5/8") receptacle for mounting beam spreaders or spatial filters. An AC adapter is included, but the unit can be powered with any power source providing 0.7 A at 12 VDC.

### Specifications

**Output:** 0.5 mW min.  
**Wavelength:** 632.8 nm  
**Polarization:** Random  
**Power:** 115/220 VAC, 50/60 Hz

### Order Information

Mini Laser –  
with Bracket ..... OS-8514

## Laser Alignment Bench

OS-9172

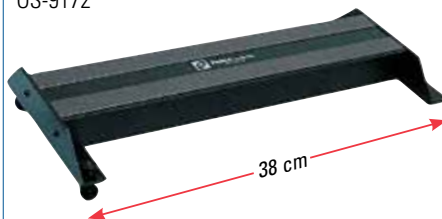

This Laser Alignment Bench connects to the Optics Bench with the included couplers. It leaves the full one-meter length of the Optics Bench free for experimental work.

### Order Information

Laser Alignment Bench ..... OS-9172

## Modulated Laser (1.5 mW)

SE-9449A

This Helium Neon Laser has two advantages over the other lasers:

1. **1.5 mW:** The extra power makes laser experiments and demonstrations brighter (and often easier). It's especially useful for holography. A shorter exposure time can be used to minimize problems with vibrations.
2. **Modulation:** Connect a microphone to this laser, and students can transmit voice through the laser beam to a distant receiver. Or use this laser as a laser stroboscope for timing.

**Note:** Additional equipment, not available from PASCO, is required for laser communication experiments.



CLASS IIIa LASER PRODUCT  
LASER RADIATION – DO NOT STARE INTO BEAM

### Specifications

**Wavelength:** 632.8 nm  
**Power:** 1.5 mW min., 3.5 mW max.  
**Beam Diameter:** 0.49 mm  
**Beam Divergence:** 1.65 mRad  
**Housing Size:** 32.8 x 7.2 x 7.4 cm  
**Modulation Range:** 85-100% of full power  
**Input Signal Frequency:** 50 Hz-600 kHz ( $\pm 3$  dB); miniature phone jack accepts audio input signals at 100 mV peak-to-peak and 60 k $\Omega$  impedance

**Transmission Range:** Effective up to several hundred feet; with a good collimator and detector, transmissions up to several thousand feet are possible

**Power:** 115 VAC, 60 Hz  
(not available in 220 V)

### Order Information

1.5 mW Modulated Laser .....SE-9449A

# Ray Optics

## Convex Mirror

SE-7574

## Concave Mirror

SE-7573

Virtual and real images are formed with these large, curved mirrors. Diameter is 60 cm. Stand is included.



### Order Information

Demonstration Convex Mirror ..... SE-7574  
 Demonstration Concave Mirror..... SE-7573

## Prisms

These prisms are made of high quality optical glass.

Equilateral Prism: 30 x 30 mm sides;  
 50 mm long

Right-Angle Prism: 23 x 32 mm sides;  
 50 mm long

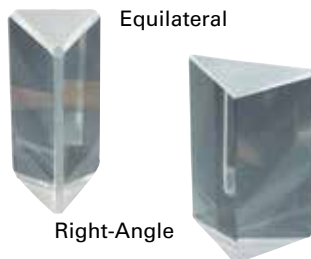

### Order Information

Equilateral Prism..... SE-9021A  
 Right-Angle Prism..... SE-9022A

## Ray Optics Kit

OS-8516A



### Includes

- Double-Convex Lens
- Double-Concave Lens
- Rhomboid
- Eye-Dropper
- Triangular mirror accessory with concave, convex, and plane reflective surfaces
- Hollow lens to fill with a liquid or use as an air lens.

### Order Information

Ray Optics Kit ..... OS-8516A

## Ray Optics Laser System

SE-8506

CLASS 2 LASER PRODUCT  
 LASER LIGHT –  
 DO NOT STARE INTO BEAM

- ▶ No need to dim the lights
- ▶ Wide variety of optical components
- ▶ Templates simulate real-world optical devices

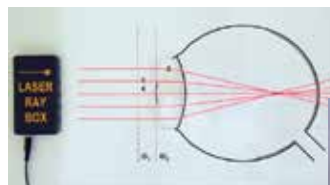

*The laser rays are focused in front of the retina by the myopic lens used with the human eye template.*

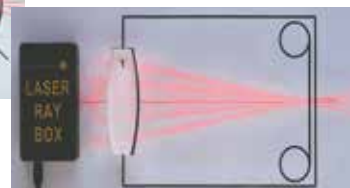

*The laser rays are redirected by the converging lens and focused on the "film" of the camera template.*

This demonstrations optics set uses a Laser Ray Box that has bright, well-defined rays because it uses lasers rather than an incandescent light source. The Laser Ray Box projects five parallel laser beams onto any flat surface. It contains five 1 mW diode lasers (wavelength 635 nm). The laser beams are spread out into clearly visible lines by cylindrical lenses inside the box.

The ray box has a magnetic back for mounting on any steel board. The unit is powered by an included AC adapter.

This exceptional optics set includes six magnetically-backed templates that have guidelines showing where to put components to perform different demonstrations, including:

- ▶ Modeling the human eye and eyeglasses
- ▶ How a camera works
- ▶ Two types of telescopes
- ▶ Spherical aberration
- ▶ Refraction and reflection

Each component has a magnetic backing for mounting on any steel board.

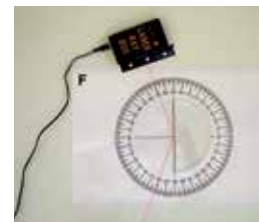

*The included protractor template can be used to demonstrate refraction.*



### Specifications for Laser Ray Box

**Dimensions:** 11 cm x 6 cm x 2 cm

**Laser Ray Separation:** 1.8 cm

**Power Adapter:** 3 VDC, 300 mA (included)

**Wavelength:** 635 nm

### Includes

- Laser Ray Box
- Laser Ray Mask
- Double-convex lenses (4)
- Double-concave lens
- Plano-concave lens
- "D" lenses (4.5 cm and 7.5 cm radius) (2)
- Plane, convex, and concave mirrors
- Right-angle prism
- Rectangle (6 cm x 10 cm)
- Optical fiber (2 cm x 20 cm)
- Templates (6)
- Steel whiteboard (56.5 cm x 41.5 cm)
- Most components are 10 cm tall and 1.7 cm thick.

### Order Information

Ray Optics Laser System..... SE-8506  
 Laser Ray Box (alone)..... SE-8505

## FLIR C3 Thermal Imaging Camera

SE-7128A



- ▶ “See” into the infrared
- ▶ Simultaneously record visible and infrared snapshots
- ▶ Stream video using FLIR tools
- ▶ Record infrared movies in PASCO Capstone
- ▶ Determine temperatures from color coding
- ▶ WiFi enabled

Extend your students’ world into the infrared with this full-featured, pocket-sized thermal camera. This infrared camera takes two pictures at once: one in the visible spectrum and one in the infrared. An outline of the visible image is superimposed on the colorized infrared picture for reference. In addition to the color temperature scale there is a digital readout of the temperature. All of this is offered at a special educator’s price.

### Consider these activities:

- ▶ Check light transmission through different media: Visible light easily passes through acrylic; IR doesn’t. Visible light is not readily transmitted through black balloons, but they are transparent in the IR, as are silicon wafers, and black plastic garbage bags.
- ▶ Slide a block on the table. We always tell our students that the energy is dissipated as heat. Show them!
- ▶ Look at your infrared reflection in a white board.
- ▶ Record infrared video in PASCO Capstone and sync to data from thermal experiments.
- ▶ Take off your shoes and follow your footsteps by looking at your infrared footprints.
- ▶ Evaluate different types of insulation.
- ▶ Measure the temperature of ice water.
- ▶ Beakers of water with different temperatures (as measured with the camera) come to some easily predictable temperature when mixed together.

### Key Features

1. Light, slim profile
2. Bright 3” touchscreen
3. Built-in LED work light and flash
4. Big snapshot button stores thermal, visible and visible overlay in each JPEG
5. Easy-access on-off button powers up fast
6. USB Micro-B file transfer and data streaming
7. Visible camera
8. Thermal camera



### Specifications

#### 3” Touchscreen

**IR Sensor:** 80 x 60 pixels

**Digital Camera:** 640 x 480 pixels

Temperature reading at each of the 4,800 pixels

**Temperature range:** -10°C to 150°C

**Accuracy:** ±2°C or 2%, whichever is greater

Onboard memory stores 500 sets of jpeg images

**USB Micro-B** connector

**WiFi**

**Rechargeable Li-ion** polymer battery with 2 h operating time

**Weight:** 0.13 kg (0.29 lb)

**Size:** (L x W x H): 12.5 x 8.0 x 2.4 cm

**Warranty:** 2-year warranty on parts and labor  
10-year warranty on detector

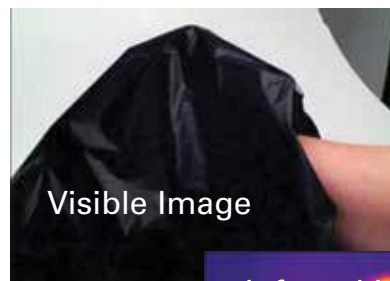

Visible Image

The FLIR takes simultaneous visible and infrared images of a hand inside a black garbage bag.



Infrared Image



The rectangular hole in the heated block (TD-8580A) appears black in visible light, but glows brightly in infrared. This is an example of cavity radiation.

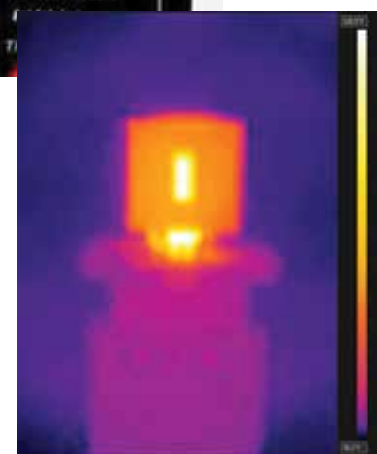

### Includes

- FLIR C3 thermal imaging camera
- Tripod mount
- Power supply/charger
- USB cable
- Research IR software
- Access to FLIR education content with lectures, experiments, and teacher guides

### Order Information

FLIR C3 Thermal Imaging Camera.....SE-7128A

# Interferometry

## Introductory Michelson Interferometer

OS-8501

- ▶ **Micrometer-controlled mirror movement**
- ▶ **Precision, front-surface optics**
- ▶ **Good quality, low price**

This interferometer is a precision instrument for the introductory lab. It's easier to use, more compact, and less expensive than PASCO's advanced interferometer (see page 297).

It's capable of measuring the wavelength of monochromatic light with an accuracy of better than 5%. The Michelson Interferometer can also be used for making precise measurements of the index of refraction of air.

### Features

#### ▶ **Smooth Mirror Movement:**

Uses a taut-band mirror movement similar to PASCO's more expensive interferometer, providing smooth movement with minimal backlash.

#### ▶ **Built-in Micrometer:**

Measures mirror movement to a fraction of a micron.

#### ▶ **Easy Setup:**

Especially easy with a laser and a PASCO Optics Bench. If a laser is unavailable, a spectral light source can be used.

#### ▶ **Complete Manual:**

Manual includes illustrated setup instructions, a detailed discussion of basic Michelson interferometry, plus two copy-ready experiments (measure the wavelength of monochromatic light, and measure the index of refraction of air). To download the manual, search for OS-8501 at pasco.com

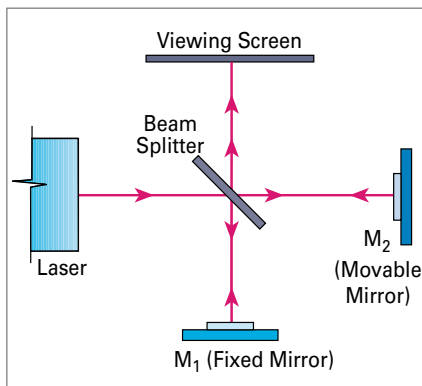

Beam-splitting schematic for a basic Michelson Interferometer.

The Introductory Michelson Interferometer provides precision interferometry at an economical price (laser and screen not included).

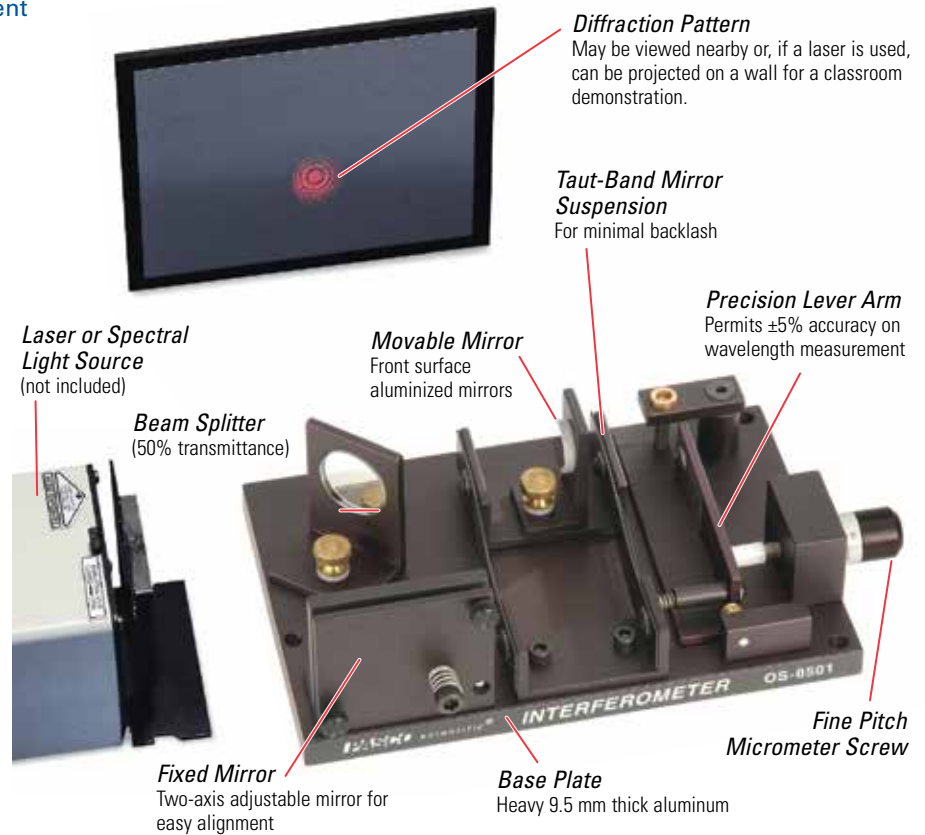

### Diffraction Pattern

May be viewed nearby or, if a laser is used, can be projected on a wall for a classroom demonstration.

### Taut-Band Mirror Suspension

For minimal backlash

### Precision Lever Arm

Permits  $\pm 5\%$  accuracy on wavelength measurement

### Optics Bench

Note: While the interferometer is designed to be used with the Optics Bench of the Advanced Optics System OS-9103, it can also be used without the PASCO Optics Bench.

### Includes

- Michelson Interferometer
- Gas Cell
- Collimating Lens (18.4 mm focal length)
- Lens Holder
- Storage Case
- Manual



### Order Information

Introductory Michelson Interferometer ..... OS-8501

#### Recommended:

Mini Laser w/Bracket..... OS-8514 p. 279

Hand-Operated Vacuum Pump w/Gauge..... OS-8502

## Hand-Operated Vacuum Pump

OS-8502

This Hand-Operated Vacuum Pump with Gauge is required to measure the index of refraction of air using the Introductory Michelson Interferometer.



Hand-Operated Vacuum Pump with Gauge

### Order Information

Hand-Operated Vacuum Pump..... OS-8502

## Complete Interferometer System with Laser

OS-9258B

- ▶ Three modes: Michelson, Fabry-Perot, Twyman-Green
- ▶ Large precision optics
- ▶ 5 kg machined aluminum base

No study of interferometry should overlook the historical importance of the Michelson interferometer. Yet in the laboratory, the Fabry-Perot and Twyman-Green interferometers can be more important tools: the first for high-resolution spectroscopy, the second for testing and producing optical components with aberrations that can be measured in fractions of a wavelength.

The PASCO Interferometer is a high-precision, movable-mirror interferometer that can be used to perform Michelson, Fabry-Perot, and Twyman-Green interferometry. Mirrors are attached with thumbscrews, so it's easy to set up and change configurations.

The PASCO Interferometer can be ordered in a variety of systems. The Precision Interferometer can be operated in either the Michelson or Fabry-Perot modes. The Complete Interferometer Systems also contain components for the Twyman-Green mode and a vacuum pump for the refractive index of air experiment. The Systems Component List shows the contents of each system.

### Features

- ▶ **Stable:** The massive (5 kg) base is machined from a single block of aluminum, ensuring extremely stable optics.
- ▶ **Smooth Mirror Movement:** With the taut-band suspension system, there's no starting or stopping friction and virtually no backlash (less than 0.5 micron).
- ▶ **Precise Measurements:** Mirror control is extremely fine—one micron per division of the micrometer head. The mirrors and beam-splitter are flat to 1/4 wavelength to ensure uniform interference patterns.
- ▶ **Larger Optics:** The 3.2 cm (1 1/4") diameter optics in the PASCO Interferometer produce larger and sharper interference patterns for better experimental results.
- ▶ **Complete:** The Precision Interferometer includes everything necessary to perform basic Michelson and Fabry-Perot interferometry.

### Order Information

Complete Interferometer System ..... OS-9258B  
 Precision Interferometer ..... OS-9255A  
 Interferometer Accessories Kit ..... OS-9256A

**Fabry-Perot Interferometry:**  
 Two parallel, partially reflecting mirrors create clear, widely spaced interference fringes.

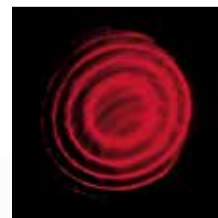

**Precision Optics**  
 Flat to 1/4 wavelength.

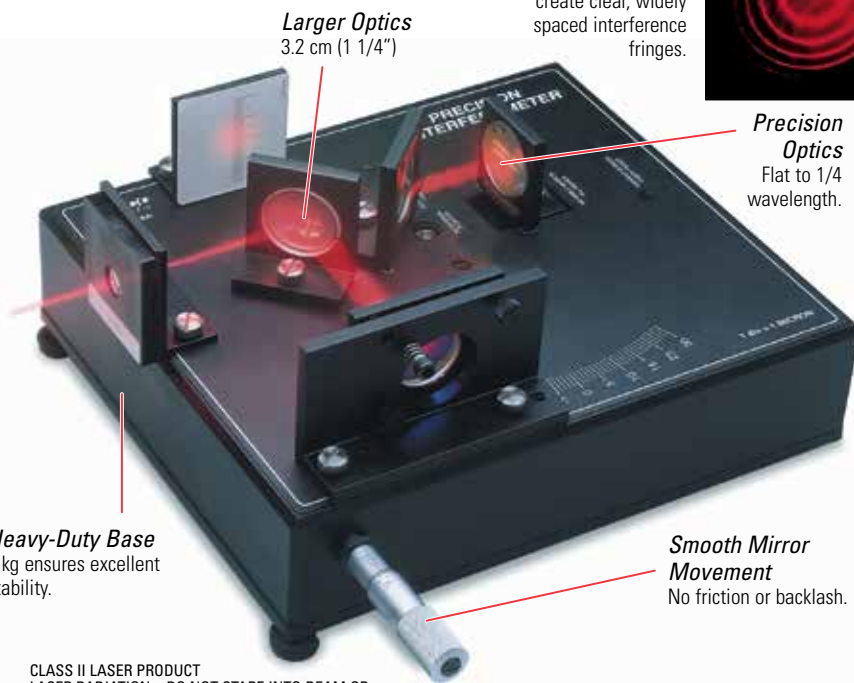

**Heavy-Duty Base**  
 5 kg ensures excellent stability.

**Smooth Mirror Movement**  
 No friction or backlash.

CLASS II LASER PRODUCT  
 LASER RADIATION – DO NOT STARE INTO BEAM OR VIEW DIRECTLY WITH OPTICAL INSTRUMENTS

The OS-9255A Interferometer in Michelson mode.

### Add the Accessories Kit (OS-9256A)

(included in the Complete Interferometer System) to:

- ▶ Demonstrate that cross-polarized beams will not interfere
- ▶ Measure lens irregularities in Twyman-Green Mode

- ▶ Measure the indices of refraction for air and glass. The indices of refraction for user-supplied materials can also be measured.

*Note: The fitted case will hold all components and accessories except the 5 kg base, which must be stored separately.*

	A. OS-9258B Complete Interferometer System with Laser	B. OS-9255A Precision Interferometer	C. OS-9256A Interferometer Accessories Kit
<b>Systems Component List</b>	<b>A</b>	<b>B</b>	<b>C</b>
Machined base—5 kg	1	1	
Three-point adjustable mirror	1	1	
Mounted beam-splitter	1	1	
Mounted movable mirror	1	1	
Accessory mounts	3	2	1
Viewing screen OS-9138	1	1	
Diffuser OS-9120	1	1	
Double convex lens (18 mm) OS-9132	1	1	
Compensator lens	1	1	
Fitted case	1	1	
Vacuum pump with gauge OS-8502	1		1
Gas cell	1		1
Calibrated polarizer OS-9109	2		2
Glass plate OS-9128	1		1
Rotating component holder	1		1
Twyman-Green lenses OS-9133, OS-9132	2		2
Mini laser with bracket OS-8514	1		
Laser alignment bench OS-9172	1		
Instruction manual	1	1	

# Microwave Optics

## Basic System

WA-9314C

## Advanced System

WA-9316A

### ► Durable construction

Parts are made of stainless steel or die-cast aluminum.

**Ethafoam® Prism with Styrene Pellets**  
Used for refraction of microwaves.

**Rotating 18 cm High Mounts**  
The transmitter and receiver rotate through a full 360° and minimize tabletop reflections.

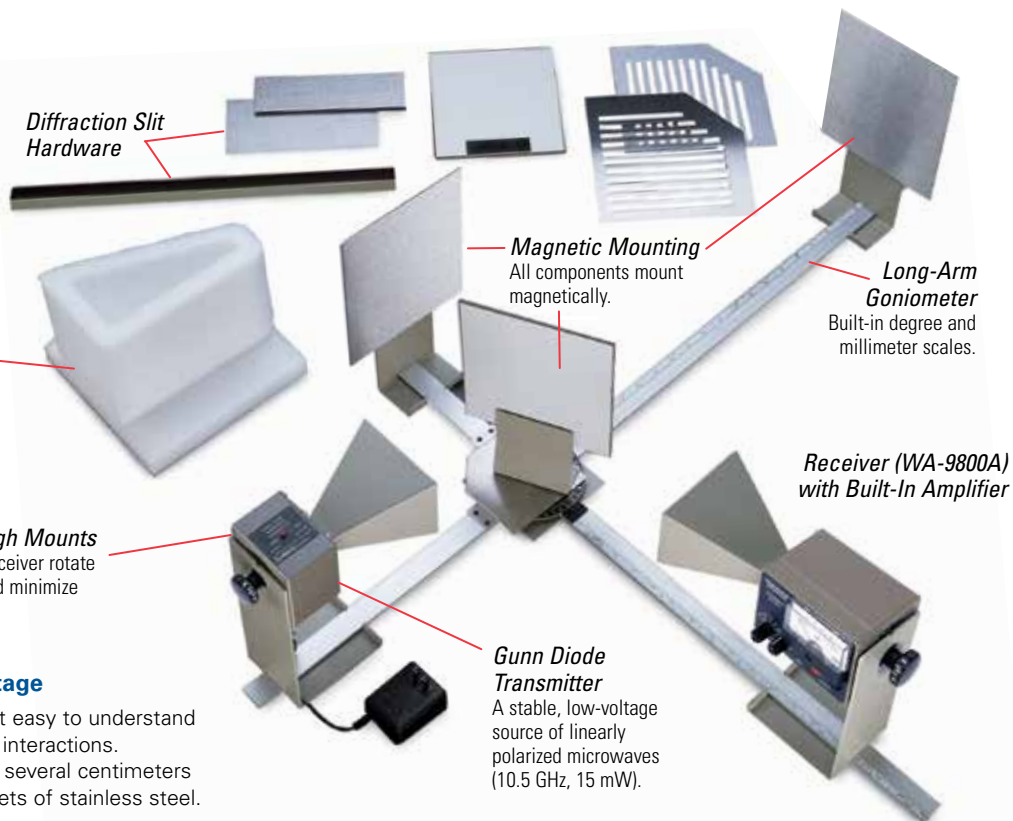

### The Microwave Optics Advantage

The large 3 cm wavelength makes it easy to understand and visualize electromagnetic wave interactions. Interference and diffraction slits are several centimeters wide, and polarizers are slotted sheets of stainless steel.

The heart of the Microwave Optics System is the Gunn Diode Transmitter and receiver. The transmitter is a low voltage source of linearly polarized microwaves (10.5 GHz, 15 mW). The receiver has a built-in amplifier, as well as a variable sensitivity scale, ensuring accurate data for even the lowest intensity measurements.

### The WA-9314C Basic Microwave Optics System includes

- Gunn Diode Transmitter with mounting stand
- Receiver with built-in amplifier and mounting stand
- Goniometer with fixed and rotatable arms and degree scale
- Fixed-arm assembly for interferometer experiments
- Component holders: two standard, one rotating
- Rotating table
- Reflectors: two full reflectors (metal), two partial reflectors (wood)
- Polarizers (2)
- Diffraction slit hardware
- Prism (Ethafoam) with styrene pellets
- AC adapter
- Laboratory manual with 12 experiments

### The WA-9316B Advanced Microwave Optics System Includes

- Basic Microwave Optics System (WA-9314C)
- Microwave Accessory Package (WA-9315)

#### Order Information

Basic Microwave Optics System.....WA-9314C  
Advanced Microwave Optics System.....WA-9316A

#### Recommended:

*The microwave transmitter and receiver assemblies may be purchased separately:*  
Microwave Transmitter.....WA-9801  
Microwave Receiver.....WA-9800A  
Microwave Mounting Stand (two needed).....WA-9802

## Microwave Detector Probe

WA-9319A

Investigate the nodes and antinodes in standing wave patterns with this microwave probe. It plugs directly into the (WA-9800A) receiver.

*Not compatible with older versions of the receiver.*



#### Order Information

Microwave Detector Probe ..... WA-9319A

## Microwave Accessory Package

WA-9315

(included in the WA-9316A Advanced System)

Includes a polyethylene panel for measuring Brewster's angle and a simulated crystal for Bragg diffraction experiments. The crystal is a cubic lattice of 100 metal spheres in a 5 x 5 x 4 array, mounted in plastic foam.



#### Order Information

Microwave Accessory Package ..... WA-9315

## FLIR C3 Thermal Imaging Camera

SE-7128A

- ▶ “See” into the infrared
- ▶ Simultaneously record visible and infrared snapshots
- ▶ Stream video using FLIR tools
- ▶ Record infrared movies in PASCO Capstone
- ▶ Determine temperatures from color coding
- ▶ WiFi enabled

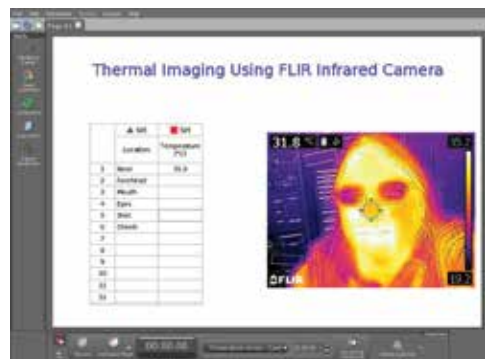

Record infrared movies in PASCO Capstone. The FLIR camera connects to a USB port or WiFi and streams images with temperature readings in Capstone. Please see page 281 for details.

### Order Information

FLIR C3 Thermal Imaging Camera..... SE-7128A

## USB Camera Microscope

PS-2343

- ▶ Use as web camera
- ▶ Optical zoom from 1x to 60x
- ▶ Built-in LED lights



The versatile USB Microscope Camera is ideal for a variety of applications in the science classroom. Its dual functionality means it can take pictures just like a digital camera, but it can also magnify like a microscope when it's up close to a specimen. It is especially useful when studying things such as crystalline structure. And you can use it to take pictures showing lab setups, such as what materials look like before and after an experiment has been performed.

### How It Works

Used with the video and image capture features in PASCO Capstone. Magnification of specimens can be done by adjusting the dial located on the front of the camera.

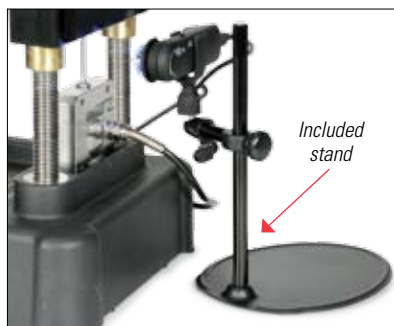

Shown in use with ME-8236 Materials Testing Machine (see page 144). As the tensile sample is being stretched, the force versus time data is graphed in sync with the movie.

### Includes

- Camera
- Microscope
- Stand

See the USB Camera Microscope in use with the Universal Gravitational Constant Experiment (EX-5550) on page 317.

### Order Information

USB Camera Microscope..... PS-2343

#### Suggested Base Supports:

- Flex Rod .....ME-8978A p. 177
- Small “A” Base .....ME-8976 p. 176
- Aluminum Clamp .....ME-8995 p. 179

## USB Digital Video Flex®

SE-7235A



- ▶ Display and record falling Millikan oil drops
- ▶ Digital signal for crisp, clear images
- ▶ High-resolution: 1920 x 1080

The high-definition 3.2 Megapixel Digital Video Flex connects directly to a PC or laptop via a fast USB 2.0 connection. The flexible gooseneck and the ball-and-socket head allow the camera to adapt easily to microscopes or to focus on scientific experiments, graphic materials, moving objects, or presenters. A custom CMOS chip and Quick Focus™ 8 mm glass lens enable this Digital Video Flex to capture superior quality images, showing details that would otherwise be missed. The ken-a-vision Applied Vision software (supplied) allows easy display and editing of pictures and videos. The lens can be focused from 6 mm to infinity, allowing magnification up to 50x for macro- and micro-photography.

No external power supply is required, as the camera is powered by the computer through the USB connection. The delivery is complete with a 28 mm microscope adapter, Discovery Scope Kit, Applied Vision software, and carrying case. The USB cable is pre-attached to the camera.

### Specifications

- Light Sensitivity:** 20 lux
- Sensor:** CMOS
- Output/Interface:** Digital / USB 2.0
- Exposure:** Software controlled
- Output Resolution:** HD 1080P
- Pixel Count:** 1920 x 1080
- Real-Time Video:** Up to 30 frames per second
- Lens:** 8 mm HD interchangeable C-mount, glass
- Focal Distance:** 1/4" (6 mm) to infinity
- Magnification:** 50:1
- Eyepiece Adapter:** 34.5 mm built-in, and 28 mm
- Power Supply:** via USB
- Cable Length:** USB connecting cable, approx. 1.5 m pre-fixed
- Gooseneck:** 65 cm length
- Base:** 7" x 7" x 7" / 180 x 180 x 180 mm, polycarbonate
- Weight:** 10 lbs / 4.55 kg
- Height:** 30" / approx. 76 cm

### Order Information

USB Digital Video Flex .....SE-7235A

# Electron Charge

## Millikan Oil Drop Apparatus

AP-8210A

- ▶ Nobel prize-quality physics in the student lab
- ▶ Ionization source for changing droplet charge
- ▶ Measures the charge of an electron to within  $\pm 3\%$

The Millikan Oil Drop Experiment is one of the most popular experiments in undergraduate physics for several reasons:

- ▶ The experimental principle is straightforward and easy to understand
- ▶ It measures a fundamental atomic constant using a method that won its originator, Robert Millikan, the Nobel Prize
- ▶ The observation of the effects of one or more electrons upon oil drops in an electric field provides a striking demonstration of the quantized nature of electricity

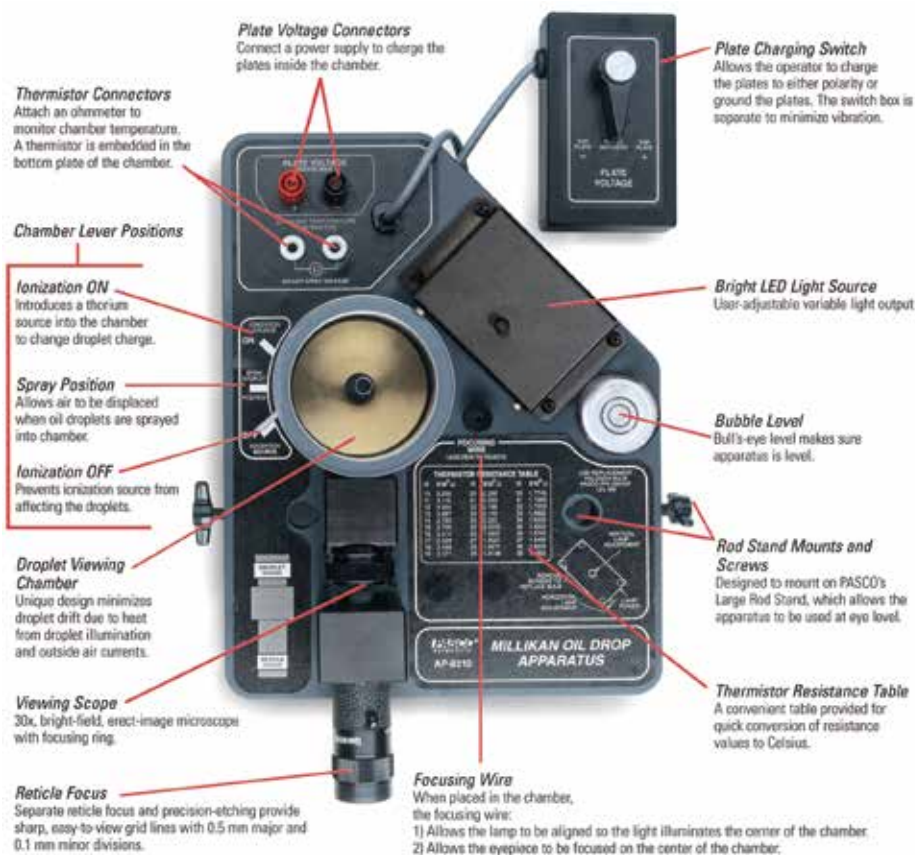

The Millikan Oil Drop Apparatus mounted on a rod stand for easy, eye-level viewing

### Specifications

- Maximum Plate Voltage:** 500 VDC
- Light Source:** Cool LED
- Reticle Line Separation:** 0.5 mm major divisions  
0.1 mm minor divisions
- Plate Spacing:** 7.62 mm
- Plate Diameter:** 60 mm



### Includes

- Millikan Oil Drop Apparatus with Switch
- Non-volatile Oil and Atomizer
- 12 VAC Lamp Power Adapter

### Order Information

Millikan Oil Drop Apparatus.....AP-8210A

#### Required:

Basic Digital Multimeter (2) .....SE-9786A p. 241

High Voltage Power Supply .....SF-9585A p. 234

#### Recommended:

For mounting unit at eye level on a standard lab table:

Large Rod Base.....ME-8735 p. 176

45 cm Steel Rod (2)....ME-8736 p. 176

#### Complete System:

Charge of an Electron.....EX-9929A p. 334

#### Replacement Part:

4 oz. Bottle Mineral Oil (qty. 4).....AP-8211

Millikan LED Light Source.....AP-8212

Clear droplet observation and low droplet drift are essential for success with Millikan's classic experiment. PASCO's apparatus uses a pre-aligned optical system and special condenser to achieve these conditions.

Accuracy in the Oil Drop Experiment depends on the student's ability to precisely measure all the variables involved: plate voltage, plate separation, time and distance of droplet rise and fall, temperature, oil density, etc. Extreme care taken in the design and manufacture of this unit ensures that the student's best efforts will be rewarded with more accurate results. Typically, a careful student can achieve results within 3% or less of the accepted value.

## Electron Charge-to-Mass Ratio System

SE-9629

- ▶ Sharp, clearly visible electron beam
- ▶ Phosphorescent mirrored scale eliminates parallax errors
- ▶ Tube rotates for general study of electrons in a magnetic field

In 1897, J. J. Thomson showed that the mysterious cathode rays were actually negatively charged particles—he had discovered the electron. In the same year he measured the charge-to-mass ratio of the electron, providing the first measurement of one of the fundamental constants of the universe.

The Charge-to-Mass Ratio System reproduces one version of Thomson's landmark experiment, providing an accurate measurement of the charge-to-mass ratio of the electron. And, since the electron tube can be rotated through 90°, students can also make a more general study of the behavior of electrons in a magnetic field.

This apparatus also has deflection plates, so students can study the effect of an electric field on moving electrons.



Complete Charge-to-Mass Ratio System includes the power supplies, which can also be used in other experiments (such as Franck-Hertz experiment, see page 303).

### How It Works

A large, helium-filled electron tube is mounted between a pair of Helmholtz coils. The tube contains an electron gun, which generates a focused beam of electrons. A measured current is applied to the Helmholtz coils so that the magnitude of the magnetic field within the electron tube can be calculated. A measured accelerating potential (V) is then applied to the electron gun. The magnetic field (B) deflects the electron beam in a circular path with a radius (r) that is measured using the illuminated mm scale. From these measured values, the charge-to-mass ratio of the electron is calculated:

$$e/m = 2V/B^2r^2.$$

(The details of the calculations are fully described in the manual.)

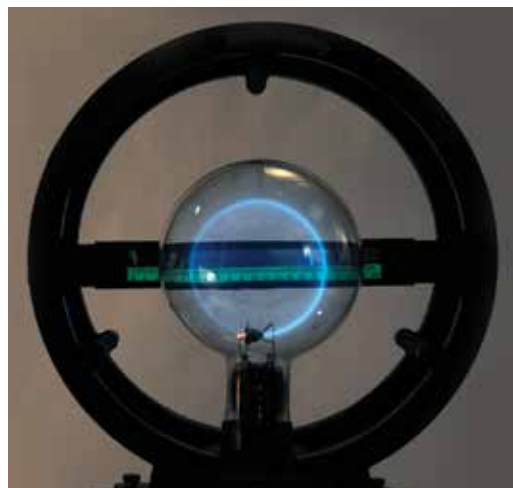

Fluorescent scale shows behind the electron beam in a dark room.

### Specifications

- Helmholtz Coil Radius:** 16 cm
- Number of Turns:** 130
- Maximum Current:** 3.5 A
- Filament Voltage:** 6.3 VAC
- Acceleration Voltage:** 0 - 200 V
- Tube Diameter:** 15.5 cm

For more information about power supplies, see page 236.

### Electron Charge-to-Mass Ratio System (SE-9629) includes:

- Helmholtz Coils *without tube* (SE-9626)
- e/m Tube (SE-9651)
- Tunable DC (Constant Current) Power Supply (SE-9622)
- Tunable DC (Constant Voltage) Power Supply II (SE-9644)
- Red and Black Patch Cords

### Order Information

Electron Charge-to-Mass Ratio System ..... SE-9629

*If you already have power supplies, you will need:*

Helmholtz Coils (without tube)..... SE-9626

e/m Tube ..... SE-9651

*Replacement Parts:*

e/m Tube (for SE-9629)..... SE-9651

# Photoelectric Effect

## Photoelectric Effect System

SE-6609

- ▶ Find Planck's Constant to within 5%
- ▶ Verify the stopping voltage is independent of intensity
- ▶ Find characteristics of photodiode

The Photoelectric Effect System is used to perform the photoelectric experiment, determining Planck's Constant to within 5%. This apparatus uses the conventional method of determining Planck's Constant. The metal plate in the photodiode is illuminated with various frequencies of light, selected from a mercury lamp using filters. The voltage is then adjusted to stop the photoelectric current. The stopping voltage is plotted versus the frequency and Planck's Constant is determined from the slope of the graph. The concept that the stopping voltage does not change with light intensity is tested using the various apertures that vary the light intensity by partially blocking the light.

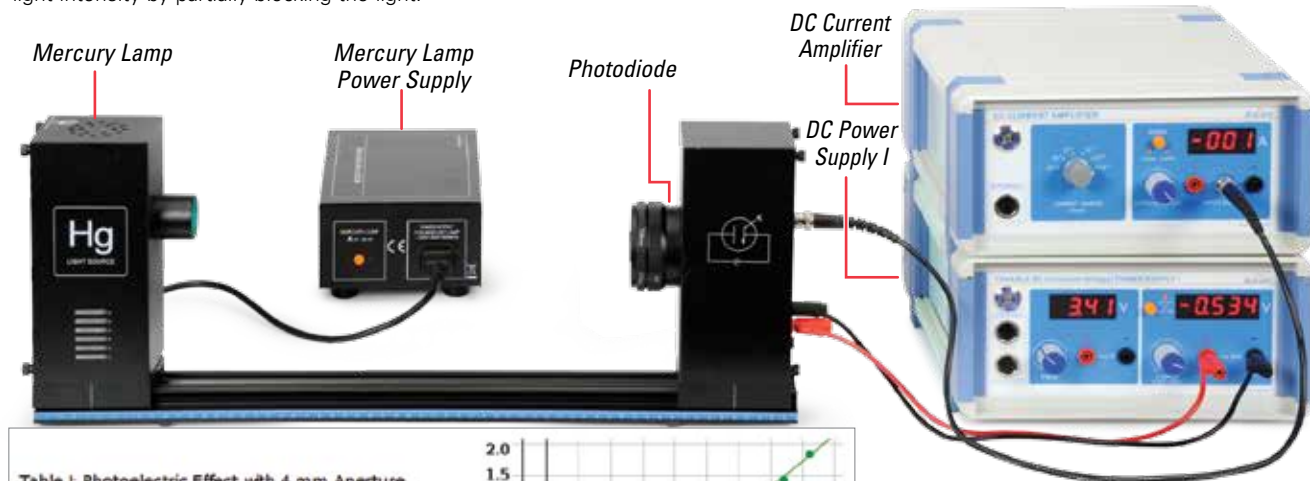
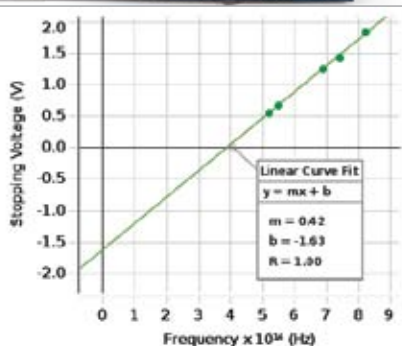

Table 1: Photoelectric Effect with 4 mm Aperture

	▲ Run #1	■ Run #1
	Frequency x 10 <sup>14</sup> (Hz)	Stopping Voltage (V)
1	8.214	1.835
2	7.408	1.428
3	6.879	1.248
4	5.490	0.671
5	5.196	0.551



For the typical sample data shown, the graph of stopping voltage versus frequency gives a slope of  $4.2 \times 10^{-15}$  V.s. This results in a value for Planck's Constant of  $6.7 \times 10^{-34}$  J.s, which is 1.3% above the accepted value. Graph generated using PASCO Capstone™ Software and 850 Interface.

The filters and the apertures are built into the front of the photodiode case, making it easy to keep clean and eliminating the need for a separate storage box. To change the aperture size in order to investigate the affect of different light intensities, simply pull outward on the aperture ring and rotate it to a different aperture. The filter wheel rotates independently of the aperture ring to select different frequencies of light. The wheel clicks into place, assuring that the filter is aligned with the aperture.



### SE-6609 includes:

- Basic Photoelectric Effect (SE-6614)
- DC Current Amplifier (SE-6621)
- DC Power Supply I (SE-6615)

### SE-6614 includes:

- Mercury Light Source with Hg Tube (SE-6608) *see page 292*
- Photodiode enclosure with tube and track and cables

Can be used with the 850 Interface (UI-5000, see p. 10) and PASCO Capstone

See the complete experiment on page 355.

Power Supply and Current Amplifier specs: See page 236.

### Specifications

#### Current Amplifier

**Measuring Range:** 10<sup>-8</sup> to 10<sup>-13</sup> A, in six ranges

#### Voltage Output for Photoelectric Tube

**Voltage Adjustment:** -4.5 V to 0 V and -4.5 V to +30 V (two ranges), 4 digit display.

#### Photoelectric Tube

**Spectral Response Range:** 300–700 nm

**Anode:** nickel ring

#### Optical Filters

**Five Filters with Central Wavelengths:** 365.0, 404.7, 435.8, 546.1, and 578.0 nm

### Order Information

Photoelectric Effect System ..... SE-6609

*If you already have the Power Supply and Amplifier, you will need:*

Basic Photoelectric Effect

Apparatus ..... SE-6614

**Replacement Parts:**

Photoelectric Tube with Box Plate .. SE-6612

## Franck-Hertz Apparatus

SE-9639

- ▶ Uses argon gas so no heating is required
- ▶ Digital displays for stand-alone use
- ▶ Can be used with the 850 Interface and PASCO Capstone

850 Universal Interface Connections for Instrument Readout

### Introduction

As early as 1914, James Franck and Gustav Hertz discovered in the course of their investigations an energy loss in distinct steps for electrons passing through mercury vapor and a corresponding emission at the ultraviolet line ( $\lambda = 254 \text{ nm}$ ) of mercury. They performed this experiment that has become one of the classic demonstrations of the quantization of atomic energy levels. They were awarded the Nobel Prize for this work in 1925.

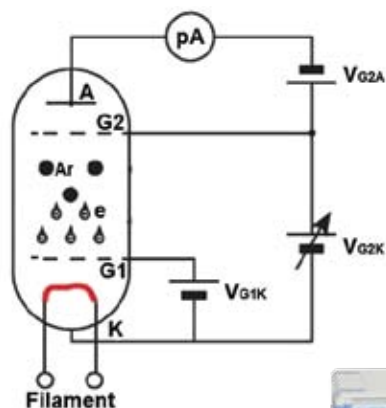

This diagram shows the internal structure of the Franck-Hertz tube and the wiring diagram.

The system can be used stand-alone or with the 850 Interface and PASCO Capstone. Each power supply and the current amplifier can be connected to 850 analog ports so Capstone can record the data.

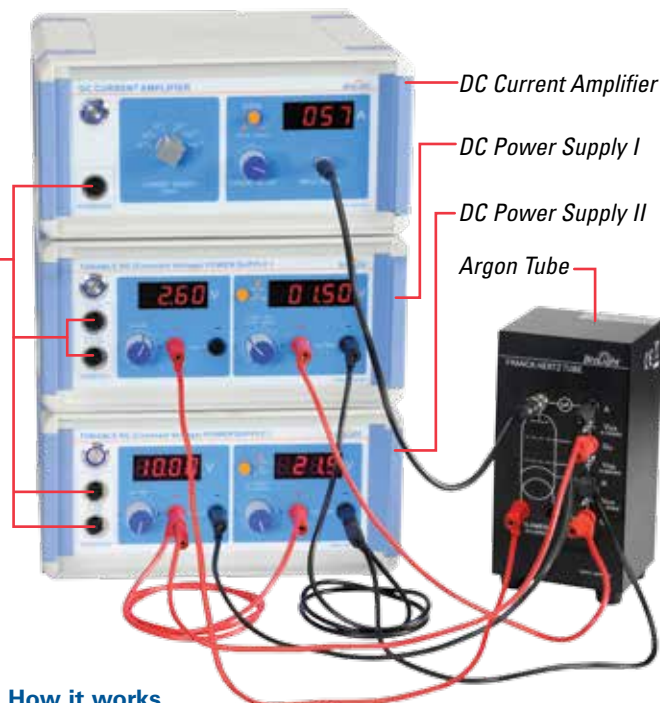

### How it works

Electrons are accelerated by applying a known potential between two grids inside the argon tube. When an electron has sufficient kinetic energy to excite one of argon's outer orbital electrons and has an inelastic collision with an argon atom, the electron loses a specific amount of kinetic energy. This loss of electron kinetic energy causes a decrease in the electron current in the argon tube. The excited argon electron will within a very short time fall from the excited state back into the ground state level, emitting energy in the form of photons.

As the accelerating voltage is increased, the electrons undergo multiple collisions and the excitation energy of the argon atom can be determined by the differences between the accelerating voltages that cause a decrease in the current. Planck's Constant can be determined.

### Specifications

- Filling gas:** argon
- Filament Voltage:**  $\leq 6.3 \text{ VDC}$
- Accelerating Voltage:**  $\leq 100 \text{ VDC}$
- Wave crest(or trough) number:** 6
- Argon Tube Life span:**  $\leq 3000 \text{ hrs}$

Power supply and current amplifier specs: See page 236.

### Franck-Hertz System (SE-9639) Includes:

- Franck-Hertz Tube Enclosure with Argon Tube (SE-9650)
- Tunable DC (Constant Voltage) Power Supply I (SE-6615)
- Tunable DC (Constant Voltage) Power Supply II (SE-9644)
- DC Current Amplifier (SE-6621)
- Red and Black Patch Cords

### Order Information

Franck-Hertz System	SE-9639
Power supplies & amplifier can be purchased separately. See p. 236	
If you already have power supplies, you will need:	
Franck-Hertz Tube Enclosure with Ar Tube	SE-9650
Replacement Parts:	
Franck-Hertz Argon Tube	SE-9645

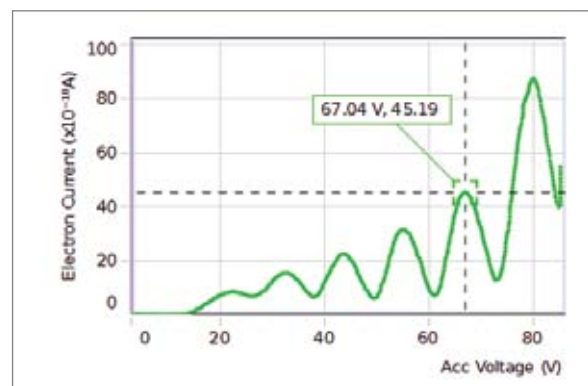

The advantage of using Capstone is that students are able to get many more data points compared to manually taking readings from the digital readouts. The peaks and troughs are easily measured using the coordinate tool.

# Hall Effect

**NEW**

## Hall Effect Apparatus (n-doped Germanium)

SE-7260

- ▶ Variable magnetic field and current
- ▶ Open design makes current direction clear
- ▶ Works with 550 or 850 Universal Interface

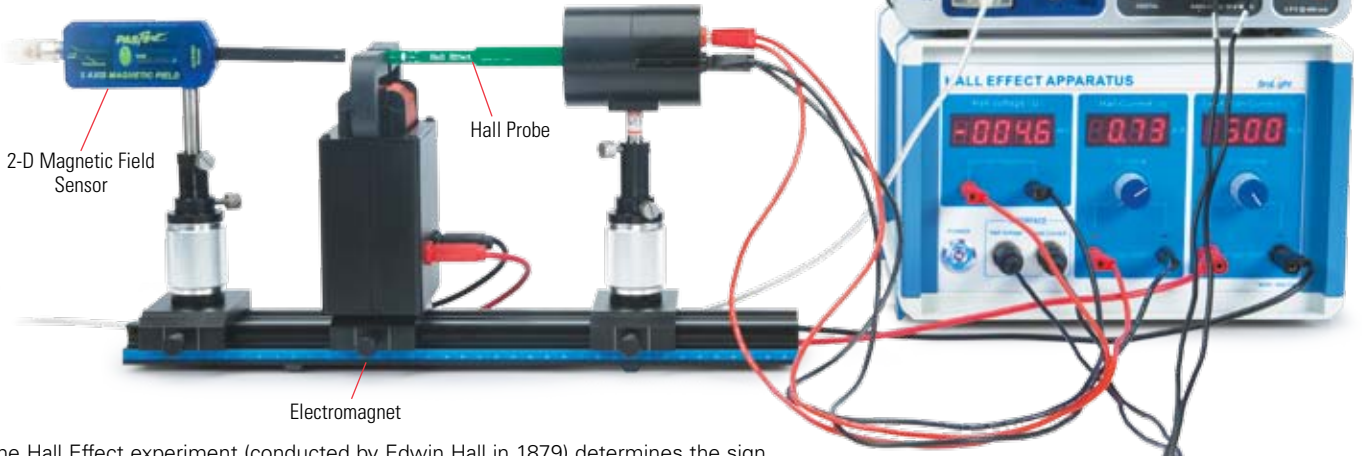

The Hall Effect experiment (conducted by Edwin Hall in 1879) determines the sign of the charge carriers in current flow. A current can be thought of as a negative charge moving in one direction (Figure 1) or as a positive charge moving in the opposite direction (Figure 2). To determine which it actually is, the semiconductor is immersed in the magnetic field transverse to the direction of flow of current. The moving charge experiences a  $q\vec{v} \times \vec{B}$  force, causing a charge build-up on one side of the semiconductor (creating an electric field), which in turn leads to a  $q\vec{E}$  force. The direction of the electric field will depend on the sign of the charge carriers and the polarity of the Hall voltage across the semiconductor reveals this sign.

The magnitude of the Hall voltage is dependent on the current, the charge carrier density, and the magnitude of the magnetic field. In modern day electronics, the Hall Effect is used to measure the magnitude and direction of magnetic fields.

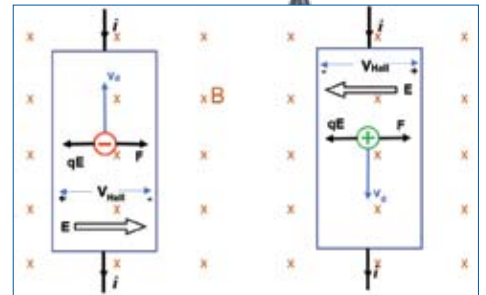

Figure 1

Figure 2

### PASCO Advantage

The open design of this Hall Effect apparatus makes it possible for students to see the direction of the current and the magnetic field, enabling them to use the sign of the Hall voltage to deduce the sign of the charge carriers.

### Specifications

- n-Doped Semiconductor Material:** GaAs
- Hall sensitivity:**  $\geq 150 \text{ mV}/(\text{mA}\cdot\text{T})$
- U-core Electromagnetic Coil (1000 Turns)**
- Magnet Space:** 10 mm
- Magnet Field:** 0 to 0.065 T (at 1A)
- Excitation Current:** 0 to 1 A DC
- Hall Voltage:** 0 to 1.9999 V
- Power Supply Digital Readout for Current, Hall Voltage, and Magnet Current**

### Includes

- Hall Probe Unit, n-Semiconductor (GaAs)
- Hall Effect Power Supply
- U-Core Electromagnetic Coil
- Track, Length 40 cm
- Optical Carrier (2)
- Adjustable Post Holder with 9 cm Post (2)
- Banana Cords (6)
- Connecting Cables for 550/850 Interface (2)
- Manual



The directions of the current and the voltage probe are clearly marked on the probe that holds the semiconductor.

Using the 550 Universal Interface to record data, this plot of the Hall Voltage vs. the Current was made in PASCO Capstone software. In this case, the magnetic field was held constant and the current through the semiconductor was varied.

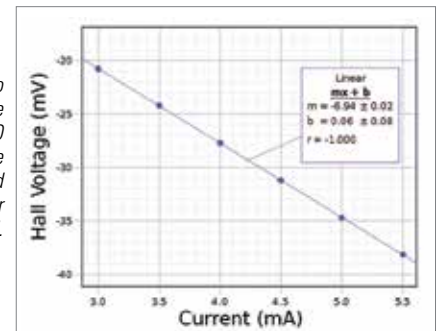

### Order Information

Hall Effect Apparatus ..... SE-7260

Note: This apparatus can be used manually by reading the digital displays. Measuring the magnetic field requires a sensor or other Tesla meter. This apparatus includes connector cables for an 850 or 550 interface so data collection can be automated.

### Required:

- 2-Axis Magnetic Field Sensor ..... PS-2162
- 850 or 550 Universal Interface ..... UI-5000 or UI-5001
- PASCO Capstone Software

## Zeeman Effect

SE-9654

- ▶ Measure the Zeeman Effect with polarization perpendicular and parallel to the field
- ▶ Observe the light along the magnet axis
- ▶ Calculate the value of the Bohr Magnetron

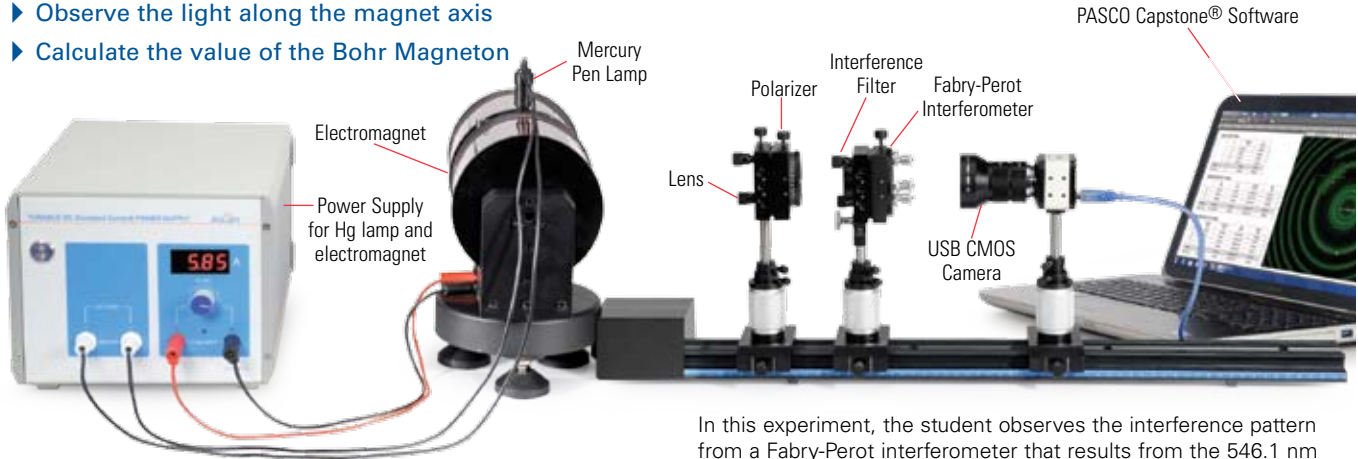

End view through the axis of the magnet.



Electromagnet produces over one Tesla.



The vertical position can be adjusted precisely with the fine-adjust mechanism.



Lens and polarizer mount can be adjusted vertically and horizontally.



The optics and track come in an aluminum hard case with foam cut-outs for each component.

In this experiment, the student observes the interference pattern from a Fabry-Perot interferometer that results from the 546.1 nm spectral line of a mercury lamp immersed in a uniform magnetic field. The magnetic field is varied from zero to nearly 1 Tesla.

Initially, the light is viewed along an axis perpendicular to the magnetic field axis. A polarizer is used to show the three lines due to light that is polarized parallel to the field axis and to show the six lines that are polarized perpendicular to the field axis. The pattern may also be viewed along the field axis where the light is circularly polarized.

Finally, the pattern that is polarized perpendicular to the field axis is used to calculate the Bohr magneton. All atomic magnetic moments are integral or half-integral multiples of the Bohr magneton.

### Specifications

<b>CMOS Camera and Lens</b>	1/3" 2M pixels, f=50 mm, RA=1:4
<b>Fabry-Perot Interferometer</b>	$\lambda=546.1$ nm
<b>Collimating Lens</b>	f=125 mm
<b>Mercury Lamp</b>	10A, 3W
<b>Electromagnet</b>	5A, 1.2T, ~7.4 mm gap
<b>Tunable DC Power Supply</b>	110V/220V, 6A
<b>Precision Adjustable Optical Mount</b>	$\Phi 45$ mm, 2D
<b>Horizontal Optical Mount</b>	$\Phi 45$ mm, travel = 36 mm, 2D
<b>Track length</b>	600 mm

### Includes

- Electromagnet
- Power supply
- Optics
- PASCO Capstone Single User License.

### Order Information

Zeeman Effect .....	SE-9654	
<i>May be purchased separately:</i>		
Electromagnet .....	SE-9655	
Tunable DC Power Supply 6A.....	SE-9656	
<i>Optional:</i>		
Tesla Meter .....	SF-7579	p. 230

Field strength as a function of the current supplied to the magnet is included in a chart. To directly measure field strength, order the optional Tesla Meter (SF-7579).

# Gravitational Torsion Balance

## Gravitational Torsion Balance

AP-8215A

- ▶ Measure the universal gravitational constant in a single lab period
- ▶ Adjustment and locking mechanisms decrease lab setup time
- ▶ Torsion band easily replaced

### Features

- ▶ View the pendulum bob's position through a mirror in the unit's central shaft. Use the leveling screws in the cast iron base to accurately center the bob.
- ▶ A special "U"-shaped groove in the locking mechanism is used to dampen the oscillation of the small lead balls.
- ▶ Easily adjust pendulum height with a single screw.
- ▶ The smooth action of the rotating large tungsten ball support ensures that the balls can be moved easily without disturbing the motion of the small tungsten balls.

**Computerized Version:**  
See the Universal Gravitational Constant experiment (EX-5550) on page 317 for a new video analysis method of tracking the laser beam.

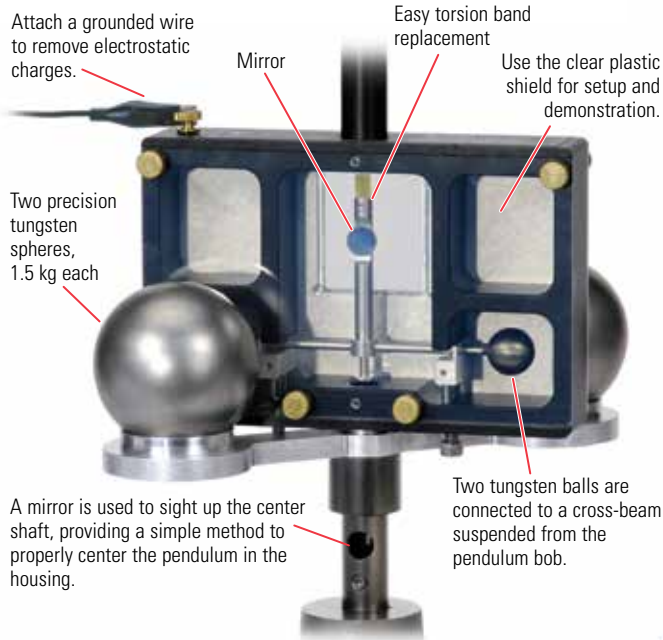

### Specifications

**Torsion Band:** Beryllium copper ribbon, 36 cm long with a cross section of 0.0178 x 0.15 mm

**Small Masses:** Two tungsten balls of 38 g each

**Large Masses:** Two tungsten balls of 1.5 kg each

**Period of Oscillation:** Eight minutes (approx.)

**Accuracy:** 5% (approx.)

### Includes

- Torsion Balance Assembly
- Extra Torsion Band (1)
- Large Rod Base ME-8735
- Manual

### Order Information

Gravitational Torsion Balance ..... AP-8215A

*Required:*

X-Y Adjustable Diode Laser ..... OS-8526A

45 cm Steel Rod ..... ME-8736

Large Table Clamp ..... ME-9472

*Replacement Supplies:*

Torsion Bands (2 pack) –

Gravitational Torsion Balance ..... AP-8218

Gravitational Balls Replacement Set ..... AP-8219

p. 176

p. 179

## Coulomb's Law Apparatus

ES-9070

- ▶ Accurately measure charge, force, and distance
- ▶ Symmetric design minimizes stray and mirror charges
- ▶ Magnetic damping for quick, accurate measurements

### How It Works

A conductive sphere is mounted on the end of an insulating, counterbalanced rod and suspended from a thin torsion wire. An identical sphere is mounted on a calibrated linear track. This second sphere can be positioned at various distances from the first. When the conductive spheres are charged, the force between them is proportional to the twist of the torsion wire that is required to bring the balance back to its equilibrium position. Beginning students can determine the Inverse Square Law in a simple experiment. Advanced students can perform a more sophisticated investigation into all the variables of electrostatic repulsion.

#### Insulated Track

The calibrated track is designed to minimize mirror charges, which can significantly affect results.

### Additional Equipment

To perform a basic experiment, the conductive spheres can be charged with a piezoelectric gun or by contact with a charged rod. This allows the Inverse Square Law to be verified with reasonable accuracy. However, for more accurate and thorough investigations, we strongly recommend the following additional equipment (see ordering information):

- ▶ A Kilovolt Power Supply, which provides a fixed and repeatable charge. The charge can be refreshed before each measurement, which practically eliminates errors due to leakage currents.
- ▶ A Basic Electrometer and a Faraday Ice Pail, for accurate measurement of the charge on the spheres (required only if you wish to measure the Coulomb Constant).

#### Built-in Scale

A degree scale on the torsion balance provides accurate measurements of the torsion wire's twist angle.

#### Magnetic Damping

Allows measurements to be made quickly.

#### Milligram Masses

Included so determining the torsion constant and verifying its linearity can be part of the experiment.

#### Built-in Millimeter Scale

#### Symmetric Construction

All conductive parts are symmetrical, so errors due to mirror charges are practically nonexistent.

#### Vary Charge Accurately

A third conductive sphere, identical to the experimental spheres, is included for reducing the charge on one or both spheres by fixed ratios. This method is quick and accurate.

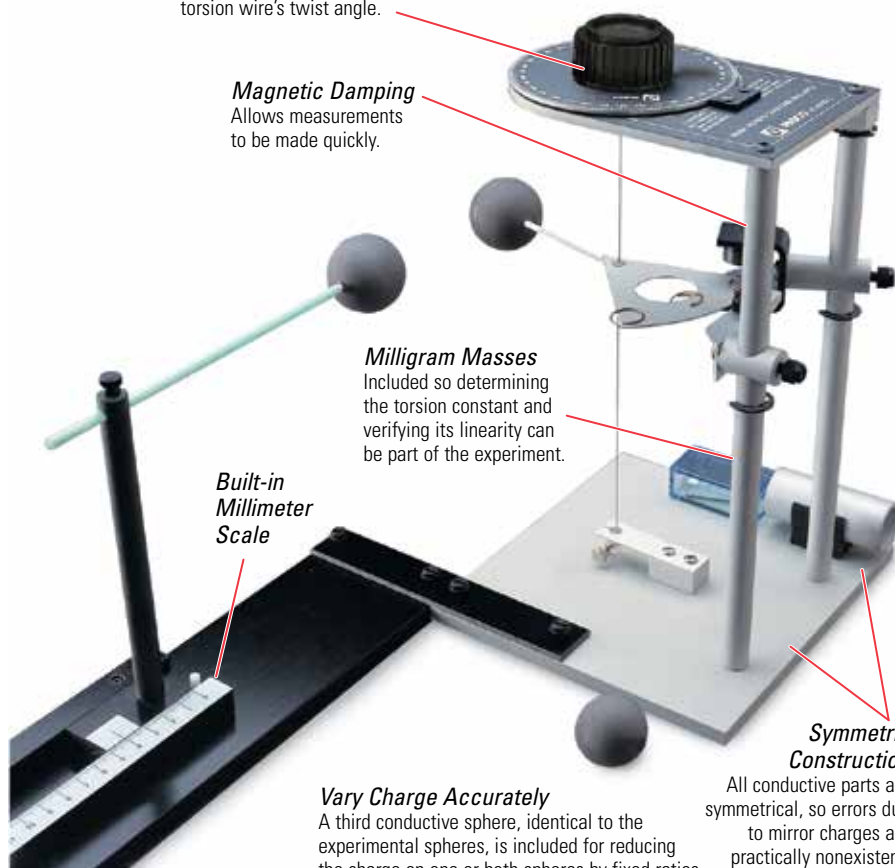

### Specifications

#### Torsion Balance:

**Torsion Assembly:** 38 mm dia. conductive sphere on 12 cm rod with counterbalance vane  
**Torsion Wire:** equals  $10^{-6}$  Newtons/degree  
**Degree Plate:**  $1^\circ$  increments  
**Magnetic Damping:** dampens oscillations for quick measurements

#### Calibrated Linear Track:

**Sphere:** 38 mm dia. conductive sphere  
**Range of Movement:** 350 mm in 1 mm increments  
**Material:** phenolic (to minimize mirror charges)

#### Miscellaneous Equipment:

**Charging Probe:** 17 cm long plus 1.5 m cable; banana plug connector;  $200 \mu\Omega$  internal resistance  
**Calibration Masses:** 50 mg (1), 20 mg (2)  
**Conductive Sphere on Insulating Thread:** for reducing charge by fixed ratios  
**Spare Torsion Wire:** 3 m

#### Shipping Information:

**Size:** 28 x 38 x 61 cm (11 x 15 x 24 in.)  
**Weight:** 9.5 kg, 21 lbs

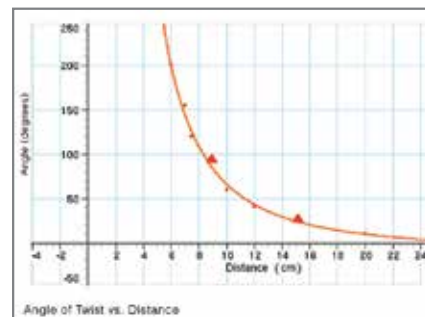

Actual data of the angle (force) vs. distance

### Order Information

Coulomb's Law Apparatus.....ES-9070

#### Recommended:

Kilovolt Power Supply .....SF-9586B p. 234  
 Basic Electrometer...ES-9078A p. 206  
 Faraday Ice Pail .....ES-9042A p. 207  
 Charge Producers.....ES-9057C p. 207  
**Complete System:**  
 Coulomb's Law.....EX-9930B p. 333

# Speed of Light

## Complete Speed of Light Apparatus

OS-9261B

- ▶ Classic Foucault Method—accurate to 5%
- ▶ 1-15 m path length
- ▶ Tabletop or hallway experiment

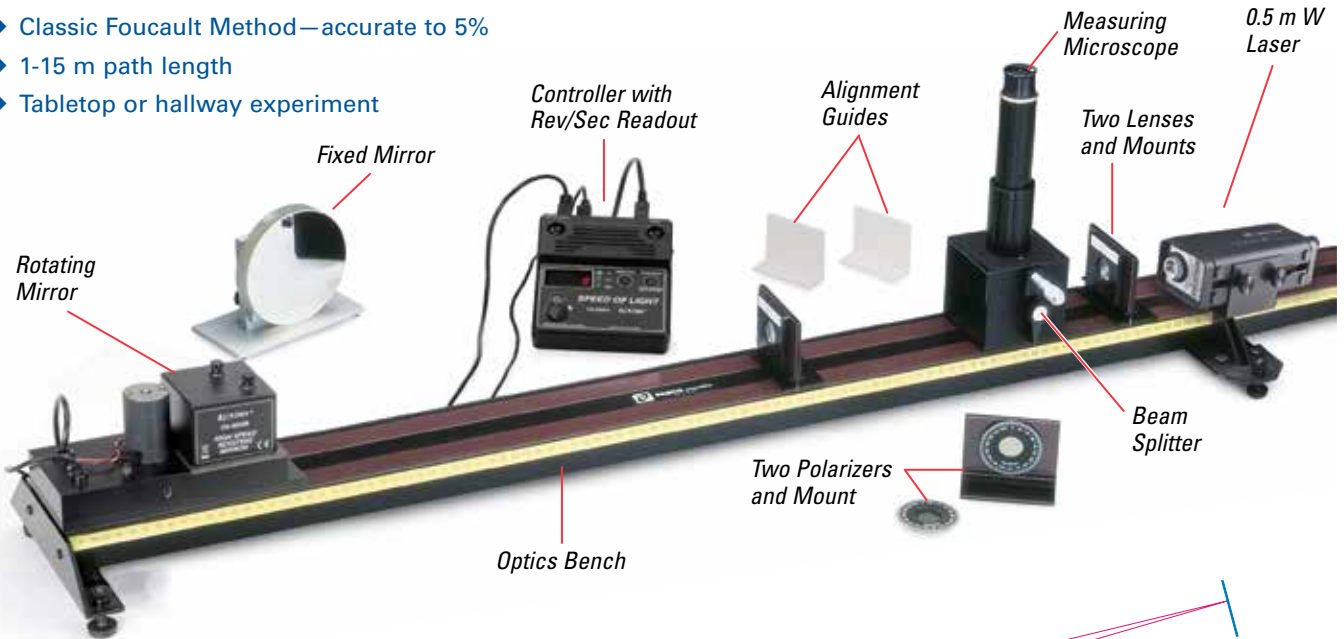

CLASS II LASER PRODUCT  
LASER RADIATION – DO NOT STARE INTO BEAM OR  
VIEW DIRECTLY WITH OPTICAL INSTRUMENTS

### How It Works— The Foucault Method

1. The first observation is made when the rotating mirror is not rotating. Light from a He-Ne laser is reflected from the rotating mirror and focused onto the fixed mirror. The fixed mirror reflects the image back onto the rotating mirror, which in turn reflects the light back through the lenses to reform the image, where it can be observed with the microscope.
2. The second observation is made when the rotating mirror is rotating. Since it takes a finite amount of time for the light to traverse the distance between the fixed and rotating mirrors, the rotating mirror is in a slightly different position when the light returns after reflecting off the fixed mirror. This produces a displacement, which can be measured with the microscope.
3. The displacement between the first and second observations is proportional to the transit time of the light to the angular velocity of the rotating mirror. With a very straightforward calculation, the speed of light can be calculated.

Speed of Light Apparatus Schematic

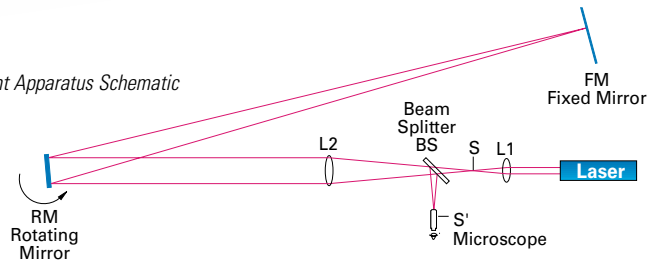

### High Speed Rotating Mirror with Controller

OS-9263B



#### Order Information

High Speed Rotating Mirror with Controller ..... OS-9263B

### OS-9261B Includes

- 1 m Optics Bench (OS-9103)
- Laser Alignment Bench (OS-9172)
- Mini Laser with Bracket (OS-8514)
- Double Convex Lens, 48 mm F.L. (OS-9133)
- Plano Convex Lens, 252 mm F.L. (OS-9135)
- Calibrated Polarizer (OS-9109)
- Component Carrier (OS-9107)

#### Order Information

Complete Speed of Light Apparatus.....	OS-9261B	
<i>Parts available separately:</i>		
Laser Alignment Bench .....	OS-9172	p. 279
Mini Laser with Bracket .....	OS-8514	p. 279
Speed of Light Experiment.....	EX-9932A	p. 348

## Laser Speed of Light System

AP-8586

- ▶ Easy setup
- ▶ Accurate results
- ▶ Low cost

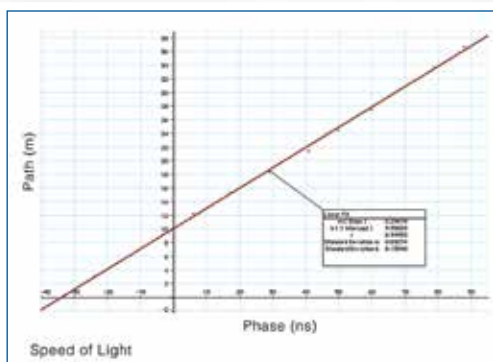

A linear fit is applied to the data, and the slope of the fit represents  $\Delta d/\Delta t$ , or the speed of light.

The Laser Speed of Light System is a low cost, yet effective method of measuring the speed of light. While it does not duplicate the classic Foucault Method, its ease of use gives every student the opportunity to perform the experiment.

### How It Works

A function generator is used to modulate the light from the laser at 3 MHz. This light is then reflected from a mirror and focused onto a light receiver. An oscilloscope is used to observe the modulated light, and the phase of the signal is noted as the baseline value for phase.

The mirror is moved back, increasing the distance that the light travels. Since it takes more time for the light to travel from the laser to the sensor, the phase of the signal on the oscilloscope increases. The phase at each successive mirror position is recorded and compared to the baseline value. The mirror is moved back several more times to get a reasonable number of data points. For each mirror position, the additional path length ( $d$ ) is graphed versus the phase difference ( $t$ ).

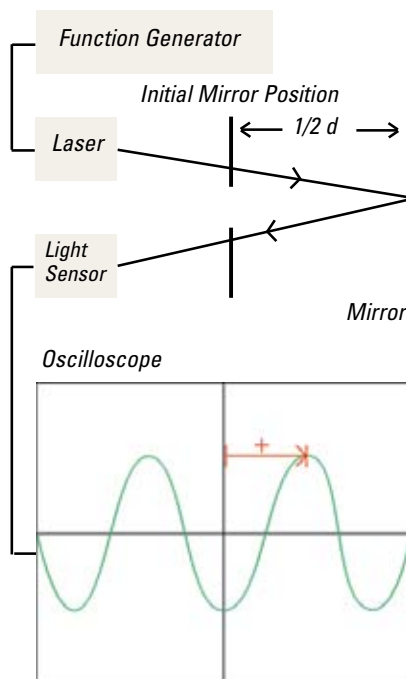

### Includes

- Diode Laser, Component Carrier (2)
- +127 mm Lens
- Laser Alignment Bench
- Light Receiver
- Stainless Steel Mounting Pads (4)
- Concave Mirror
- Coaxial Cable– RCA male to BNC male
- Coaxial Cable– 3.5 mm phone plug to BNC male
- Coaxial Cable– BNC male to male

### Order Information

Laser Speed of Light System ..... AP-8586

Required:

Wide Range Function Generator .... SB-9549A

Tape Measure (30 m)..... SE-8712A

Standard Photo Tripod

Digital Oscilloscope..... SB-9621A

# Nuclear Radiation

## Intermediate Nuclear Laboratory System USB

SN-7900A (Win/Mac)

- ▶ Macintosh, Windows, or stand-alone option
- ▶ Complete system

PASCO's most sophisticated stand-alone G-M System provides a wide range of experiments with alpha, beta, and gamma radiation. Includes a versatile scaler, a G-M Tube with a mount and trays, and a full set of radioactive sources and absorbers.

### Features

- ▶ Preset Timing and Counting Intervals: (in seconds) 1-9, 10-90, 100-900, 1K-9K, 10K-90K, 100K-900K. Intervals are selected using the Preset switch.
- ▶ Digital Display: Bright 6-decade digital read-out uses extra-large LEDs for clear readout in most ambient light conditions.
- ▶ Built-in Power Supply: 0 to 1200 V for the G-M Probe.

### Advanced Scaler/Timer

The Radiation Counter SN-7902 is a versatile, general purpose Scaler/Timer.

### Sensitive G-M Probe

- ▶ Suitable for alpha, beta, and gamma radiation detection.
- ▶ Rugged and versatile mount: made of sturdy plastic for years of rugged use. It comes with one sample holder and 10 shelf positions.

### Large Variety of Absorbers

The Absorber Set SN-8111A includes four lead, 10 aluminum sheets, two polyethylene, two plastic, and two aluminum foil absorbers, ranging from 5 mg/cm<sup>2</sup> to 7200 mg/cm<sup>2</sup>

### Five Radioactive Sources

- |            |           |             |     |
|------------|-----------|-------------|-----|
| 1. Po-210: | 0.1 μCi,  | 138 days,   | α   |
| 2. Sr-90:  | 0.1 μCi,  | 28.6 years, | β   |
| 3. Co-60:  | 1 μCi,    | 5.27 years, | β,γ |
| 4. Tl-204: | 0.25 μCi, | 3.78 years, | β,γ |
| 5. Cs-137: | 0.25 μCi, | 30.2 years, | β,γ |

The five sources are USNRC License Exempt (US only). Outside the US, consult your local laws and regulations.

### Computer Compatibility

The bi-directional LABLINK software allows full control of the Radiation Counter from the computer. LABLINK provides real-time display of a simulated analog rate-meter with auto-ranging, digital ratemeter in CPM or CPS, count, elapsed time, preset count, preset time, acquisition time, and run number. Data is loaded into spreadsheet-compatible files.



Main screen display from LABLINK software



### Includes

1. SN-7902 Radiation Counter with RADEM and LABLINK software and manual
2. SN-7970A G-M Probe (35 mm) and stand
3. USB Cable
4. SN-8111A Calibrated Absorber Set (20)
5. SN-7972A Radioactive Sources (5)
6. Two CDs with installation instructions and nuclear science experiments

### Order Information

Intermediate Nuclear Laboratory System, USB ..... SN-7900A

Required:

Isotope Generator Kit\*... SN-7995A

**\*Note:** Purchased Sources are "Non-Cancellable" and "Non-Returnable". See Radioactive Source Disclaimer on the Order Information page 382.

## Advanced Nuclear Spectroscopy System, USB

SN-7901B (Windows)

- ▶ Sophisticated Spectroscopy system
- ▶ Multi-channel analysis

Designed for spectroscopy applications, the Universal Computer Spectrometer (1) offers complete support for standard scintillation detectors together with multi-channel scaling for decay and time-related studies. The multi-channel analyzer contains many advanced features, including computer-controlled amplifier and high voltage for G-M tubes, upper- and lower-level discriminators, data memory, and a comprehensive software package.

Main screen display for Universal Computer Spectrometer

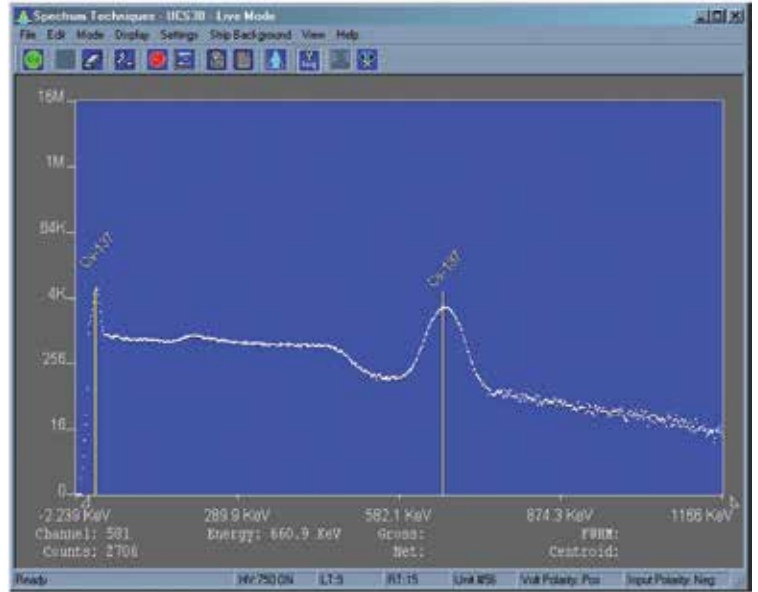

### Features

- ▶ **Variable Voltage:** A regulated high voltage of 0 to 1280 V is supplied with computer control (1 mA maximum, 5 V increments).
- ▶ **Amplifier:** On-board combination preamplifier/amplifier for use with scintillation detectors and PMTs.
- ▶ **Complete Computer Control:** When used in MCA mode, the software provides complete computer control of all features including preset live/real-time, preset count, unlimited regions-of-interest, and centroid, gross, and net area calculations.
- ▶ **Multiple Memory Buffers:** In addition to on-board hardware data memory, the spectrometer provides three software memory buffers for holding spectra. A background spectrum may be collected over a long counting period and stored in the background buffer.

### Specifications

- Hardware:**
- Physical:** Interface card or box includes pre-amplifier, amplifier, detector high voltage, 1024 channel analyzer with data memory, LLD and ULD
- ADC:** Wilkinson-type with 80 MHz clock and computer selected conversion gain of 256, 512, or 1024 channels
- High Voltage:** 0-1280 V, 1 mA maximum
- Amplifier:** Preamplifier/amplifier combination. Computer controlled coarse/fine gain from x2 to x1000
- Modes:** MCA for pulse height analysis, or MCS for half-life decay or other time-related studies

### Software:

- Energy Calibration:** 2-point linear or 3-point quadratic converts cursor position reading directly to energy units
- Computer Display:** Vertical scale adjusts from 32 to 16 M and LOG display. Horizontal 1024 channels with expansion down to 128 channels
- ISOMATCH:** Isotope library text file with peak markers and labeling for overlaying on spectrum for quick isotope identification. Library may be edited and expanded.

### Includes

1. Universal Computer Spectrometer, USB
2. NaI (TI) Scintillation Probe
3. Gamma Sources (8)
4. Connection Cables
5. Installation, Instruction, and Experiment CDs (2)

The sources are USNRC License Exempt (US only). Outside the US, consult your local laws and regulations.

### Order Information

Advanced Nuclear Spectroscopy System, (Windows) USB\* ..... SN-7901B

**\*Note:** Purchased Sources are "Non-Cancellable" and "Non-Returnable". See Radioactive Source Disclaimer on the Order Information page 382.



# Radiation Counters

## G-M Probe with Sample Holder

SN-7970A



The 35 mm diameter window provides excellent photon efficiency for detecting low activity samples. The G-M Probe has a 200  $\mu$ s dead time. Contains 10 shelf positions and is designed to accommodate the larger G-M Probe. The probe can be removed from the holder and comes with a standard BNC connector cable.

### Specifications

**Mica Window:**  $\leq 2$  mg/cm<sup>2</sup>

**Probe Dimensions:** 11.25 x 3.5 cm (4.5 x 1.4 in.) OD, excluding connector

**Operating Voltage:** 900 V, 150 V plateau

### Order Information

G-M Probe..... SN-7970A

## Radiation Counter

SN-7902 (Win/Mac)



Using a specialized microcontroller, many of the features previously found only in multiple products are now combined in PASCO's Radiation Counter.

The classic nuclear scaler function has been extended to include a timer, preset counter, digital ratemeter with alarm, computer interface, and battery power for field applications. The alarm level may be set to any preselected value.

### Features

► **Preset Scaler/Timer**

► **Large 6-digit LED display**

► **Computer Programs:** For Win and Mac computers, LABLINK offers full computer control of all functions including preset count, preset time, count rate in CPM or CPS, alarm level, start, stop, reset, data transfer, and high-voltage setting.

► **Includes USB Cable**

### Specifications

**High Voltage:** 0-1200 V, digitally selectable in 25 V increments

**Software:**

**RADEM:** Runs on Win and Mac computers including CGA, EGA, VGA, SVGA, and Hercules

**LABLINK:** Requires EGA or VGA graphics

**Dimensions:** 31 x 21 x 12 cm (12 x 8 x 4.5 in.)

### Order Information

Radiation Counter, USB .....SN-7902

## Nuclear Experiments with a Computer Interface

### Geiger-Muller Tube

SN-7927A



A Geiger-Muller Tube is available for use with PASCO interfaces. The Geiger-Muller Tube can also be used with any PASPORT interface with a Digital Adapter. No Digital Adapter is required for use with the 500, 750, or 850. Easy portability makes them ideal alpha, beta, and gamma radiation detectors.

### Specifications

**Sensitivity:** Beta, gamma, alpha

**Count Detection:** Audio signal

**Window Thickness:** 1.5 to 2 mg/cm<sup>2</sup>, mica

**Gas Filling:** Neon, Argon, and Halogen

**Starting/Operating Voltage for Tube:** 450 VDC/500 VDC

**Dead Time:** 90  $\mu$ s

### Order Information

Geiger-Muller Tube.....SN-7927A

The following sources are mounted in 2.5 cm diameter sealed plastic disks. All sources and isotopes on this page are USNRC License Exempt (US only). Outside the US, consult your local laws and regulations. Shown below are the isotopes, activity, half-life, and types of radiation (alpha- $\alpha$ , beta- $\beta$ , gamma- $\gamma$ ).

**\*Note:** "Non-Cancellable" and "Non-Returnable". See Radioactive Source Disclaimer on page 383.

## Radioactive Sources

SN-8110



- |           |              |            |                 |
|-----------|--------------|------------|-----------------|
| 1. Po-210 | 0.1 $\mu$ Ci | 138 days   | $\alpha$        |
| 2. Sr-90  | 0.1 $\mu$ Ci | 28.6 years | $\beta$         |
| 3. Co-60  | 1 $\mu$ Ci   | 5.27 years | $\beta, \gamma$ |

### Order Information

Radioactive Sources\*

(set of 3).....SN-8110

**\*Note:** "Non-Cancellable" and "Non-Returnable". See Radioactive Source Disclaimer on page 382.

## Radioactive Sources

SN-7972A



- |           |               |            |                 |
|-----------|---------------|------------|-----------------|
| 1. Po-210 | 0.1 $\mu$ Ci  | 138 days   | $\alpha$        |
| 2. Sr-90  | 0.1 $\mu$ Ci  | 28.6 years | $\beta$         |
| 3. Tl-204 | 0.25 $\mu$ Ci | 3.78 years | $\beta$         |
| 4. Co-60  | 1 $\mu$ Ci    | 5.27 years | $\beta, \gamma$ |
| 5. Cs-137 | 0.25 $\mu$ Ci | 30.2 years | $\beta, \gamma$ |

### Order Information

Radioactive Sources\*

(set of 5).....SN-7972A

**\*Note:** "Non-Cancellable" and "Non-Returnable". See Radioactive Source Disclaimer on page 382.

## Individual Sources



### Order Information

- |         |               |            |                 |         |
|---------|---------------|------------|-----------------|---------|
| Po-210* | 0.1 $\mu$ Ci  | 138 days   | $\alpha$        | SN-9085 |
| Sr-90*  | 0.1 $\mu$ Ci  | 28.6 years | $\beta$         | SN-9796 |
| Tl-204* | 1 $\mu$ Ci    | 3.78 years | $\beta$         | SN-9797 |
| Co-60*  | 1 $\mu$ Ci    | 5.27 years | $\beta, \gamma$ | SN-9794 |
| Cs-137* | 5 $\mu$ Ci    | 30.2 years | $\beta, \gamma$ | SN-9795 |
| Cs-137* | 0.25 $\mu$ Ci | 30.2 years | $\beta, \gamma$ | SN-7942 |
| Tl-204* | 0.25 $\mu$ Ci | 3.78 years | $\beta$         | SN-7941 |

**\*Note:** "Non-Cancellable" and "Non-Returnable". See Radioactive Source Disclaimer on page 382.

## Gamma Sources

SN-7949A



- |  |               |            |                  |
|--|---------------|------------|------------------|
| 1. Co-60   | 1 $\mu$ Ci    | 5.27 years | $\beta, \gamma$  |
| 2. Na-22   | 1 $\mu$ Ci    | 2.60 years | $\beta+, \gamma$ |
| 3. Mn-54   | 1 $\mu$ Ci    | 313 days   | $\gamma$         |
| 4. Cs-137  | 0.25 $\mu$ Ci | 30.2 years | $\beta, \gamma$  |
| 5. Ba-133  | 1 $\mu$ Ci    | 10.5 years | $\gamma$         |
| 6. Cd-109  | 1 $\mu$ Ci    | 464 days   | $\gamma$         |
| 7. Co-57   | 1 $\mu$ Ci    | 270 days   | $\gamma$         |
| 8. "UNKNOWN": mixture of Cs-137 and Zn-65 for student testing. |               |            |                  |
- Cs-137 is 0.25  $\mu$ Ci or lower.

### Order Information

Gamma Sources\*

(set of 8).....SN-7949A

**\*Note:** "Non-Cancellable" and "Non-Returnable". See Radioactive Source Disclaimer on page 382.

## Absorbers

SN-8111A



This set of 20 calibrated absorbers includes four lead, two plastic, 10 aluminum sheets, two polyethylene and two aluminum foil absorbers. Absorbers vary in density from 5 mg/cm<sup>2</sup> to 7200 mg/cm<sup>2</sup>.

### Order Information

Absorbers

(set of 20).....SN-8111A

## Isotope Generator Kit (Barium-137m)

SN-7995A



This Cs-137/Ba-137m Isotope Generator is used to demonstrate the properties of radioactive decay. Based on the original Union Carbide patented design, it offers exceptional performance, ease-of-use, and safe operation.

Each generator contains 10  $\mu$ Ci of Cs-137. The generator can produce up to 1000 small aliquots of the short-lived Ba-137m isotope with a half-life of 2.6 minutes.

Each generator is supplied with 250 mL of eluting solution (0.9% NaCl in 0.04M HCl). The parent isotope Cs-137 with a half-life of 30.1 years beta decays (94.6%) to the metastable state of Ba-137m. This further decays by gamma emission (662 keV) with a half-life of 2.6 min. to the stable Ba-137 element. During elution, the Ba-137m is selectively "milked" from the generator, leaving behind the Cs-137 parent. Regeneration of the Ba-137m occurs as the Cs-137 continues to decay, re-establishing equilibrium in less than 1 hour.

Approximately 30 minutes after elution, the residual activity of the Ba-137m sample has decayed to less than one thousandth of its initial activity, making it safe for disposal. When used with the eluting solution supplied, bleed-through of the parent Cs-137 is less than 50 Bq/mL, affording a long working life. Each kit is supplied with the generator, syringe, tube, 250 mL of solution, and a storage case.

### Order Information

Isotope

Generator Kit\* .....SN-7995A

**\*Note:** "Non-Cancellable" and "Non-Returnable". See Radioactive Source Disclaimer on page 382.

# Cloud Chamber

## Diffusion Cloud Chamber

SE-7943

- ▶ No dry ice required
- ▶ View cosmic rays
- ▶ Built-in illumination

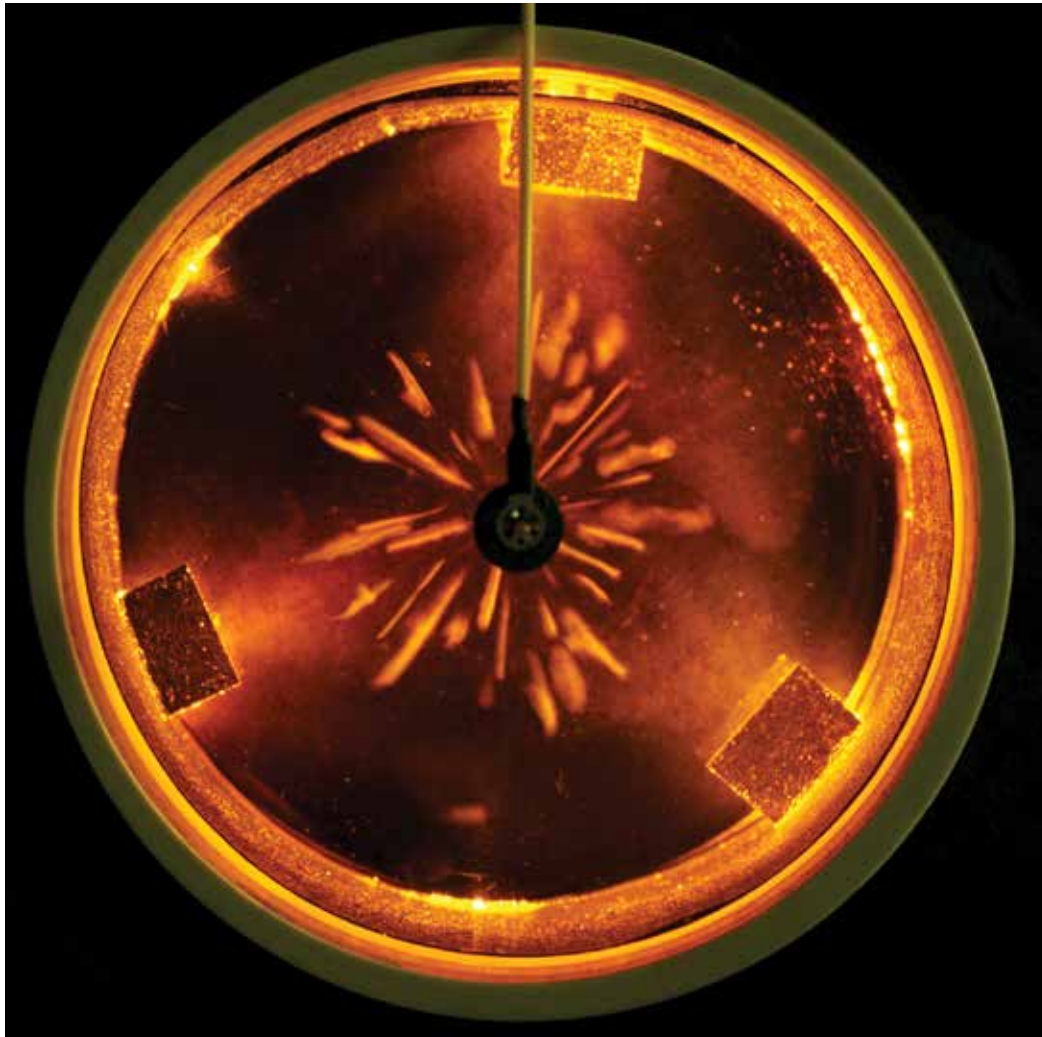

The Diffusion Cloud Chamber is used to view high energy alpha particles, lower energy beta particles, and electrons produced by gamma rays interacting with gas molecules.

### How It Works

The bottom of the chamber is cooled by circulating ice water through the base and further cooling it to  $-35^{\circ}\text{C}$  with a Peltier device. Alcohol placed in the chamber wicks up the inside chamber lining where it evaporates in the warmer region of the chamber and diffuses downward. The alcohol vapor is then cooled near the chamber bottom and becomes super saturated.

As energetic alpha and beta particles from a radioactive source pass through the alcohol vapor, the vapor condenses, forming droplets that appear as tracks in the strong chamber cross-lighting.

### Features

- ▶ Uses ice water instead of dry ice
- ▶ Water circulation pump
- ▶ Built-in high voltage ( $\sim 800\text{ V}$ ) power supply for clearing the chamber of unwanted ions
- ▶ Powered by 12 V DC power adapter
- ▶ Built-in LED lamps for illuminating the particle trails



*Particle tracks are visible from radioactive particles given off by the Pb-210 source at the center. The dense straight tracks are produced by alpha particles and the fainter, crooked tracks are produced by beta particles.*

**Includes**

- Cloud Chamber
- 12 VDC Power Adapter (6 A)
- Water Circulation Pump
- Two Rubber Hoses
- Extraction Pipette
- Source Holder and Stopper
- High Voltage Connection Cable
- SpecTech™ Coupon for Pb-210 Source Needle

**Specifications**

**Diameter:** 15 cm  
 12 VDC Power Adapter (6 A)  
**Water Circulation Pump:** 120 V/ 60 Hz, 3 W, 180 liter/hr  
**Built-in High Voltage Source:** ~800 VDC with  $10^8 \Omega$  protection resistor  
**Rubber Hoses:** 0.25" ID (6.4 mm ID), 60 cm long  
**High Voltage Connection Cable:** 22 cm long, Banana plug to ring lug  
 Eight Amber LEDs

**Order Information**

Diffusion Cloud Chamber.....SE-7943  
 Diffusion Cloud Chamber – No Source.....SE-7940  
**Required:**  
 Ice Water  
**Recommended:**  
 Pb-210 Replacement Radioactive Needle Source\*.....SE-7945  
 The Needle Source is USNRC License Exempt (US only).

*\*Note: Purchased Sources are "Non-Cancellable" and "Non-Returnable". See Radioactive Source Disclaimer on the Order Information page 382.*



# Introduction to Experiments

## Download **FREE** PASCO Capstone Experiments

Over 50 classic physics experiments for use with PASCO equipment and software

The following pages present classic experiments in physics performed with PASCO apparatus.

Manuals can be downloaded at [www.pasco.com](http://www.pasco.com). Interfaces and software, where indicated, should be ordered separately.

Everything else is included in the experiment: apparatus, sensors (when needed), and accessories.

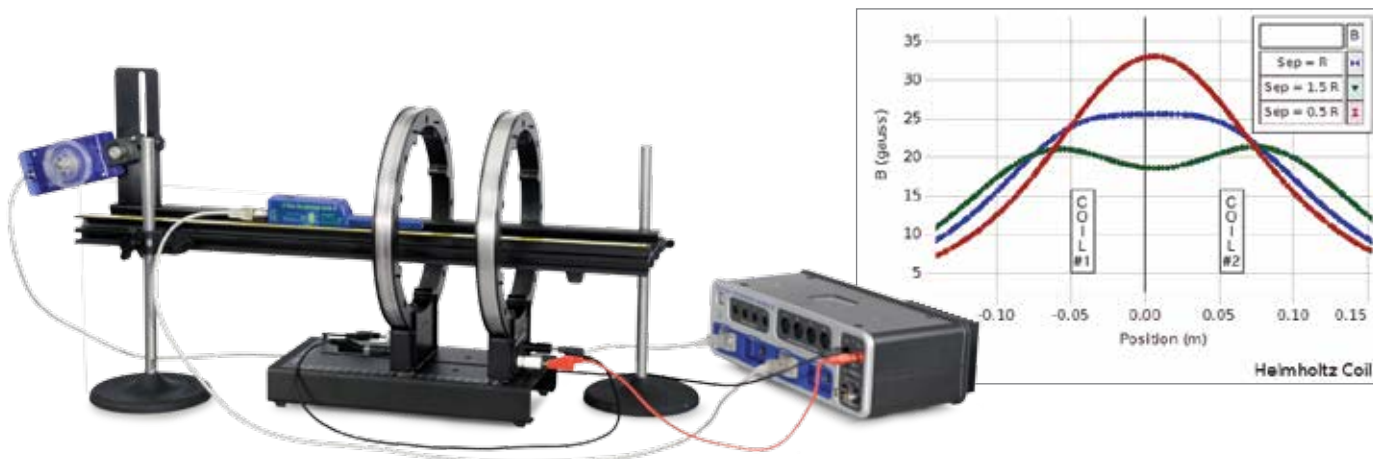

Workbooks include all instructions needed to perform the experiment:

- ▶ Introduction and theory
- ▶ Detailed setup instructions including full-color photos
- ▶ Detailed analysis and summary questions
- ▶ Step-by-step instructions

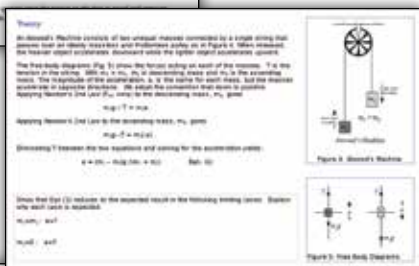
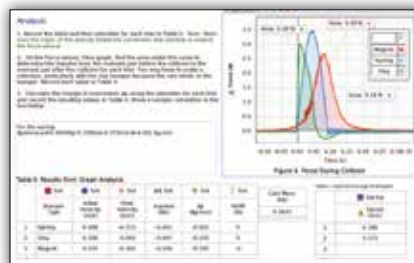

## Download This Experiment

Each experiment manual and the PASCO Capstone™ workbook files may be downloaded free at [www.pasco.com/CapstoneExperiments](http://www.pasco.com/CapstoneExperiments)

### ▶ Experiment Manual:

A detailed experiment manual helps ensure student success. An electronic Word® version is included for modification by the teacher.

### ▶ PASCO Capstone Workbook File:

PASCO Capstone workbook files are included for each experiment. These files contain workbooks with step-by-step instructions with embedded live data displays. Use these files with students. A file with sample data is also included.

EXPERIMENT LIST	PAGE NO.	EXPERIMENT NUMBER	850 UNIVERSAL INTERFACE	550 UNIVERSAL INTERFACE	PASPORT PORTS	DIGITAL ADAPTER	NO INTERFACE REQUIRED
<b>Mechanics</b>							
Atwood's Machine	304	EX-5501	●	●	1	1	
Projectile Motion	305	EX-5502	●	●	2	2	
Newton's Laws	306	EX-5503A					●
Hooke's Law	307	EX-5504A	●	●	1		
Centripetal Force on a Pendulum	308	EX-5505A	●	●	2		
Centripetal Force	309	EX-5506	●				
Sliding Friction	310	EX-5508	●	●	2		
Impulse	311	EX-5509A					●
Conservation of Momentum	312	EX-5510B					●
Ballistic Pendulum	313	EX-5511A	●	●	1		
Conservation of Energy	314	EX-9935					●
Conservation of Energy II	315	EX-5512	●	●	1		
Work Energy Theorem	316	EX-5513A	●	●	2		
Universal Gravitational Constant	317	EX-5550					●
Archimedes' Principle	318	EX-9909					●
Rotational Inertia	319	EX-5516A	●	●	1		
Physical Pendulum	320	EX-5518A	●	●	1		
Conservation of Angular Momentum	321	EX-5517A	●	●	1		
<b>Oscillations</b>							
Bridge Vibrations	356-357	EX-5548	●				
Variable-g Pendulum	322	EX-5519A	●	●	1		
Large Amplitude Pendulum	323	EX-5520A	●	●	1		
Driven Damped Harmonic Oscillator	324	EX-5522A	●				
Chaos	325	EX-5523A	●				
<b>Thermodynamics</b>							
Specific Heat	326	EX-5524A	●	●	1		
Electrical Equivalent of Heat	327	EX-5525	●				
Ideal Gas Law	328	EX-5527	●	●	1		
Blackbody Radiation	329	EX-5529A	●				
Heat Engine Cycle	330	EX-5530B	●		3		
Ratio of Specific Heats	331	EX-5531A	●	●	1		
<b>Electromagnetism</b>							
Electrostatic Charge	332	EX-5532					●
Coulomb's Law	333	EX-9930B					●
Charge of an Electron	334	EX-9929A					●
Capacitance	335	EX-5533	●	●			
Resistivity	336	EX-5534	●				
Ohm's Law	337	EX-5535	●	●			
RC Circuit	338	EX-5536	●	●			
LRC Circuit	339	EX-5537	●				
Kirchhoff's Circuit Laws	340	EX-5538	●	●			
Earth's Magnetic Field	341	EX-5539A	●	●	2		
Magnetic Forces on Wires	342	EX-9933					●
Magnetic Fields of Coils	343	EX-5540A	●				
Faraday's Law of Induction	344	EX-5541A	●	●			
<b>Waves and Optics</b>							
Vibrating String	345	EX-5542	●				
Waves	346	EX-9952					●
Reflection and Refraction	347	EX-9987					●
Speed of Light	348	EX-9932A					●
Telescope/Microscope	349	EX-9988					●
Polarization of Light	350	EX-5543A	●	●	2		
Brewster's Angle	351	EX-5544A	●		3		
Light Intensity vs. Distance	352	EX-5547A	●	●	2		
Interference and Diffraction of Light	353	EX-5545A	●	●	2		
<b>Quantum</b>							
Atomic Spectra	354	EX-5546B	●	●	2		
Photoelectric Effect	355	EX-5549A	●	●			

# Mechanics

## Atwood's Machine

EX-5501

### Concepts:

- ▶ Newton's Second Law of Motion
- ▶ Newton's Second Law of Rotational Motion
- ▶ Rotational inertia

Designed for use with any of the following:

- ▶ 850 Universal Interface
- ▶ 550 Universal Interface
- ▶ AirLink with Digital Adapter

In this classic experiment students use a very low mass/low friction pulley and measure the changing velocity of the unbalanced mass system. They interpret the slope of the velocity graph as acceleration. They examine the effect of the rotational inertia of the pulley and estimate the friction forces based on experimental data.

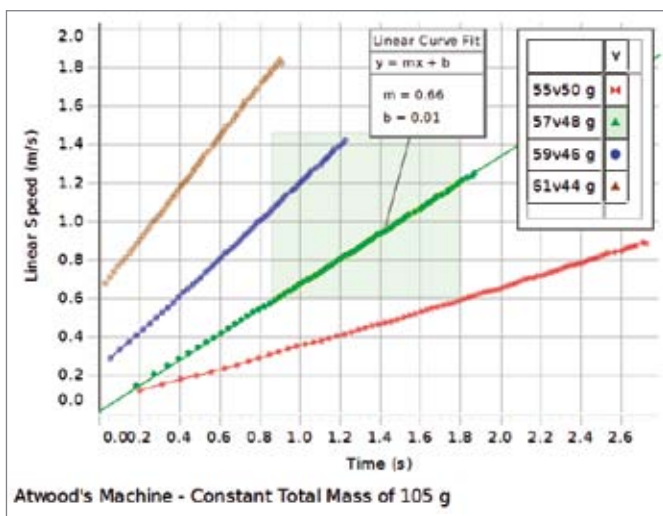

The acceleration of the weights is determined using the slope of the velocity vs. time graph. From this, the acceleration due to gravity can be found.

### PASCO Advantage

The Super Pulley/Photogate System makes it easy for students to set up the apparatus and take data. Analysis includes accounting for friction and the rotational inertia of the pulley.

### Download This Experiment

The FREE experiment files include instructions in Microsoft Word™, PASCO Capstone™ workbook files with sample data, and graphics. Download files these experiments at [www.pasco.com/CapstoneExperiments](http://www.pasco.com/CapstoneExperiments).

### Experiment Includes

- Photogate/Pulley System ME-6838A
- Mass and Hanger Set ME-8979
- Universal Table Clamp ME-9376B
- 60-cm Long Threaded Rod ME-8977
- Multi Clamp ME-9507
- Braided Physics String SE-8050



### Order Information

Atwood's Machine..... EX-5501

#### Required:

550 or 850 Universal Interface\* ..... pp. 12-14  
 PASCO Capstone Software ..... pp. 18-20  
 Balance or Scale ..... p. 186  
 Calipers..... SE-8710 p. 182

\* This experiment can be performed using the 550 or 850 Universal Interface or AirLink with Digital Adapter.

## Projectile Motion

EX-5502

### Concepts:

- ▶ Independence of x- and y-motion
- ▶ Muzzle velocity vs. time of flight
- ▶ Angle vs. horizontal range

Designed for use with any of the following:

- ▶ 850 Universal Interface
- ▶ 550 Universal Interface with 2 Digital Adapters
- ▶ Any PASPORT interface with 2 ports and 2 Digital Adapters

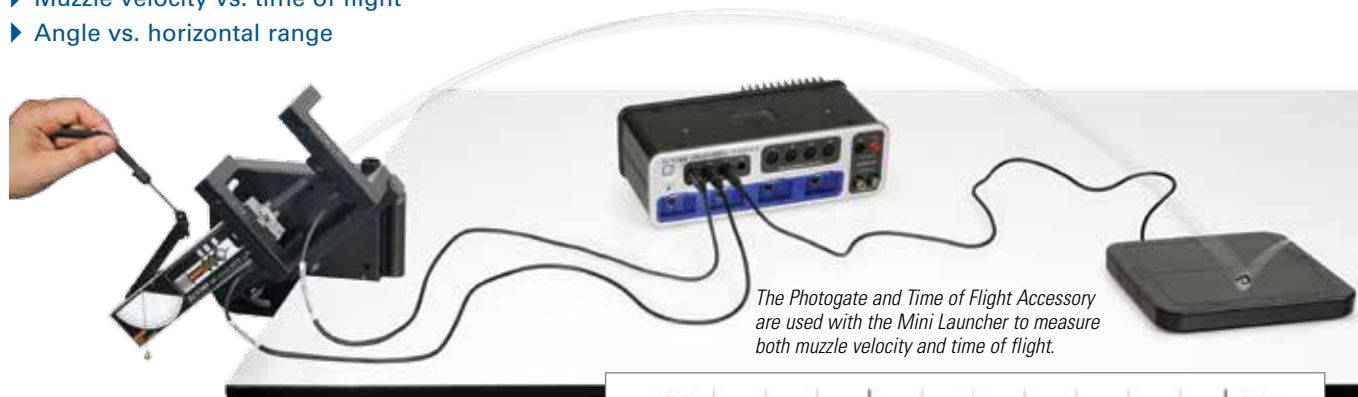

The Photogate and Time of Flight Accessory are used with the Mini Launcher to measure both muzzle velocity and time of flight.

### Muzzle Velocity vs. Time of Flight

Students fire the projectile at three different velocities from the same height. The Photogate and Time of Flight Accessory are used to measure the time of flight at each muzzle velocity. Students are surprised to find that time of flight is not related to muzzle velocity at 0° launch angle.

### Angle vs. Horizontal Range

The angle of launch is varied and the horizontal range measured for each angle. Students produce a graph of angle vs. horizontal range. The angle of maximum range can then be found. This experiment is conducted for two cases:

- ▶ Projectile is fired from a higher vertical position than its landing position
- ▶ Projectile is fired from the same vertical position as its landing position

Students are asked to use the kinematics equations to predict the horizontal range given a launch angle and muzzle velocity. Carbon paper and a bulls-eye can then be used to test their hypothesis.

### PASCO Advantage

PASCO projectile launchers are designed for repeatable and accurate launches. In addition, photogates and other accessories are designed to work seamlessly with our projectile launchers. These features allow student predictions and calculations from the kinematics equations to be empirically verified.

### Experiment Includes

- |                             |          |
|-----------------------------|----------|
| • Mini Launcher             | ME-6825A |
| • Time of Flight Accessory  | ME-6810A |
| • Phone Jack Extender Cable | PI-8117  |
| • Photogate Head            | ME-9498A |
| • Photogate Bracket         | ME-6821A |
| • Carbon Paper              | SE-8693  |
| • Large "C" Clamp           | SE-7285  |
| • Plumb Bob (need 1 only)   | SE-8728  |
| • Metric Measuring Tape     | SE-8712A |

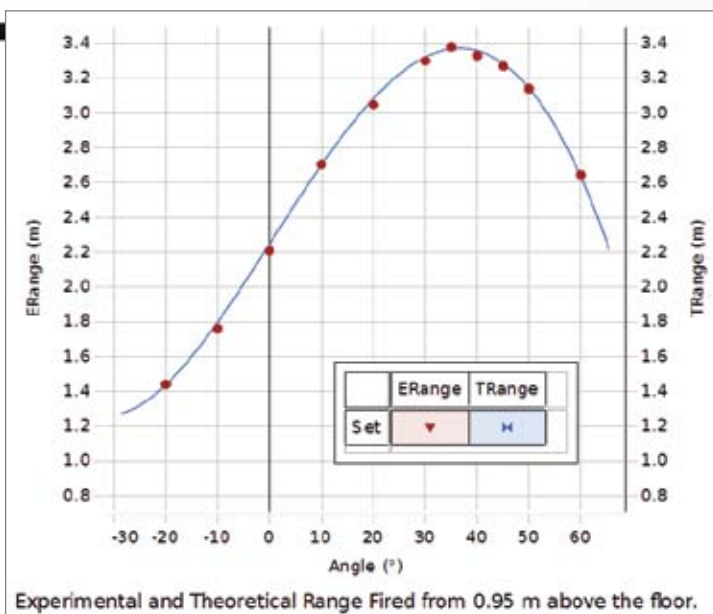

Experimental and Theoretical Range Fired from 0.95 m above the floor.

Students can use their data to determine which launch angle produces the maximum horizontal range.

### Download This Experiment

The FREE experiment files include instructions in Microsoft Word™, PASCO Capstone workbook files with sample data, and graphics. Download these experiments at [www.pasco.com/CapstoneExperiments](http://www.pasco.com/CapstoneExperiments).

### Order Information

Projectile Motion ..... EX-5502

#### Required:

850 or 550 Universal Interface\* ..... pp. 12-14  
 PASCO Capstone Software ..... pp. 18-20

\* This experiment can be performed using the 850 Universal Interface, the 550 Universal Interface with 2 Digital Adapters, or any 2 PASPORT interface with 2 ports and 2 Digital Adapters.

# Mechanics

## Newton's Laws

EX-5503A

Concepts:

- ▶ Newton's First Law (Inertia)
- ▶ Newton's Second Law ( $F = ma$ )
- ▶ Newton's Third Law ( $F_{ab} = -F_{ba}$ )

▶ No interface required

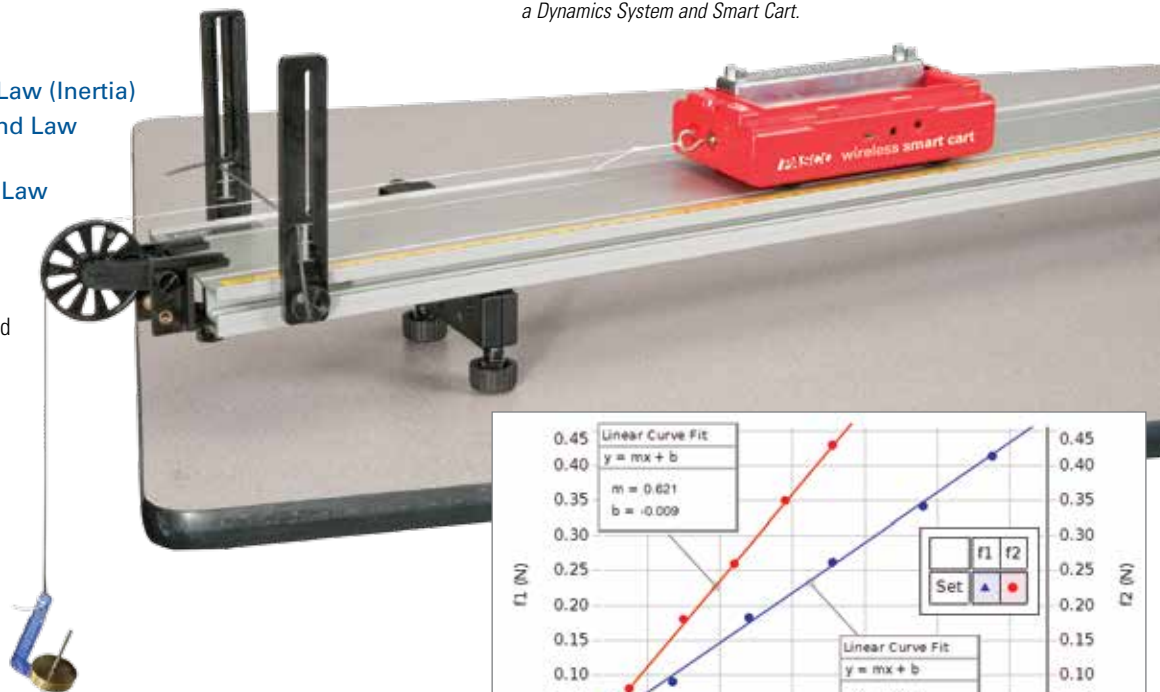

Students can effectively study Newton's Second Law with a Dynamics System and Smart Cart.

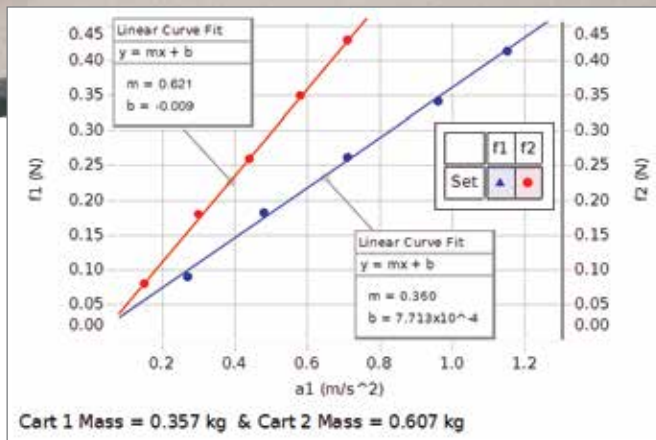

Force vs. acceleration data for the cart as it experiences changing net force

### Method

Students use this collection of equipment to discover or experimentally determine all three of Newton's Laws.

**Newton's First Law** – Students examine an object's motion to see if it changes when forces are applied or not.

**Newton's Second Law** – Students use the Smart Cart to discover the relationships between force, mass, and acceleration.

**Newton's Third Law** – Using two Smart Cart Force Sensors, students prove that forces between objects are equal in magnitude yet opposite in direction. These experiments include both tug-of-war exercises and collisions between cars.

### PASCO Advantage

The Smart Cart has all the sensors required, which makes setup very quick and easy. The integration between the probeware and equipment helps students focus on the physics of each experiment.

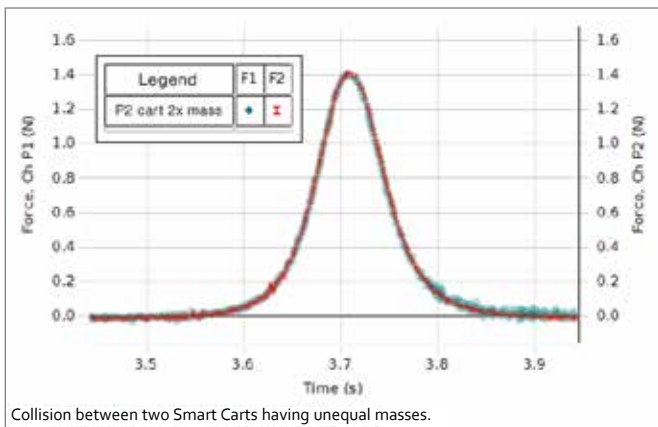

Collision between two Smart Carts having unequal masses.

### Experiment Includes

- Smart Cart (Red) ME-1240
- Smart Cart (Blue) ME-1241
- Cart Mass (set of 2) ME-6757A
- Dynamics Track Feet (Pair) ME-8972
- PASCO Mass and Hanger Set ME-8979
- Elastic Bumper ME-8998
- Super Pulley with Clamp ME-9448B
- 1.2 m Aluminum Dynamics Track ME-9493
- Friction Block ME-9807
- Braided Physics String SE-8050

### Download This Experiment

The FREE experiment files include instructions in Microsoft Word™, PASCO Capstone workbook files with sample data, and graphics. Download these experiments at [www.pasco.com/CapstoneExperiments](http://www.pasco.com/CapstoneExperiments).

### Order Information

Newton's Laws..... EX-5503A

Required:

Bluetooth 4.0 enabled computer

PASCO Capstone Software..... pp. 18-20

## Hooke's Law and Energy Stored in a Spring

EX-5504A

### Concepts:

- ▶ Relationship between force and spring deformation
- ▶ Investigate both spring compression and extension
- ▶ Amount of energy stored in a spring

### Method

In this experiment, students use a High Resolution Force Sensor to measure the force exerted to either compress or extend various springs, and a Motion Sensor to measure position and speed. Students create a Force vs. Stretch (or Compression) graph. The slope of this graph is known as the spring constant, while the vertical intercept is the initial loading force. Various springs of different construction are included, so students can better understand the physical meaning of the spring constant. The spring is then compressed (or stretched) and released. The kinetic energy transferred to a PAScar is measured and compared to the potential energy lost by the spring.

Designed for use with any of the following:

- ▶ 850 Universal Interface
- ▶ 550 Universal Interface
- ▶ Any PASPORT interface with 2 ports

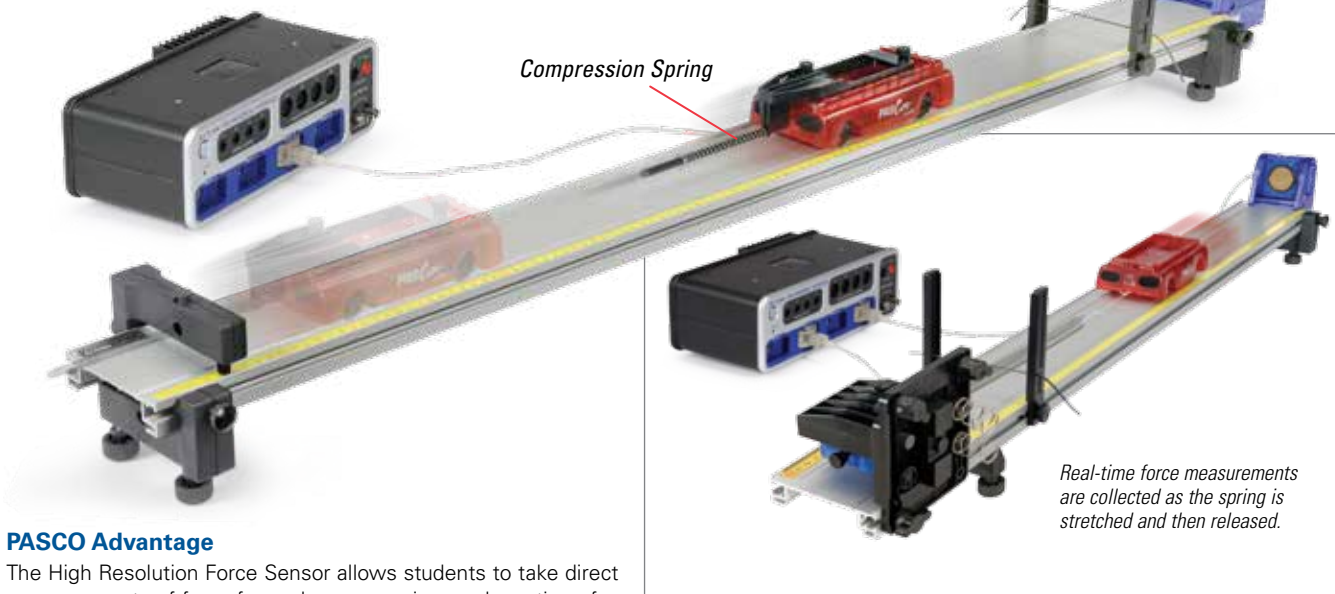
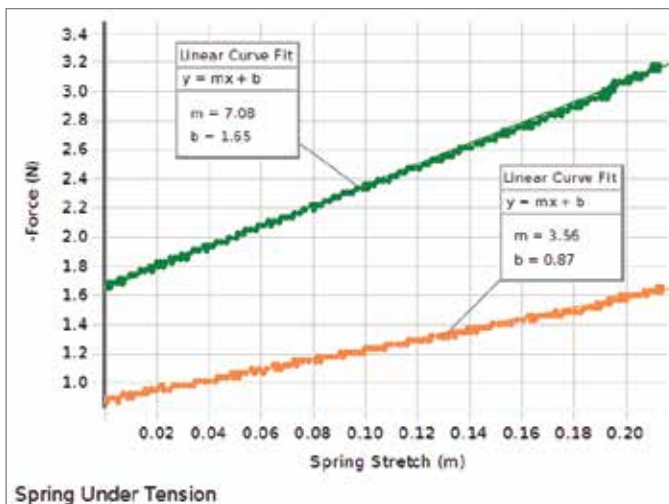

### PASCO Advantage

The High Resolution Force Sensor allows students to take direct measurements of force for each compression or elongation of the spring. This is superior to using a hanging mass to apply a force, since students don't have to convert from mass to force. In addition, students are applying the forces to the springs and will have a better kinesthetic feel for the amount of force being applied in each case. Energy changes are easily measured and very visual.

### Experiment Includes

- 1.2 m PAScar Dynamics System ME-6955
- Motion Sensor PS-2103A
- Dynamics Track Spring Set ME-8999
- High Resolution Force Sensor PS-2189
- Force Bracket ME-6622
- Spring Cart Launcher ME-6843
- Elastic Bumper ME-8998
- Physics String SE-8050

### Download This Experiment

The FREE experiment files include instructions in Microsoft Word™, PASCO Capstone workbook files with sample data, and graphics. Download these experiments at [www.pasco.com/CapstoneExperiments](http://www.pasco.com/CapstoneExperiments).

### Order Information

Hooke's Law and Energy Stored in a Spring ..... EX-5504A

#### Required:

550 or 850 Universal Interface\* ..... pp. 10-11  
 PASCO Capstone Software ..... pp. 18-20

\* This experiment can be performed using the 550 or 850 Universal Interface or any PASPORT interface with 2 ports.

# Mechanics

## Centripetal Force on a Pendulum

EX-5505A

### Concepts:

- ▶ Centripetal force
- ▶ Angular velocity
- ▶ Periodic motion

Designed for use with any of the following:

- ▶ 850 Universal Interface
- ▶ 550 Universal Interface
- ▶ Any PASPORT interface with 2 ports

*The force, position, and velocity can be monitored for the entire range of motion. Note that the position and velocity are not sinusoidal for this large amplitude pendulum.*

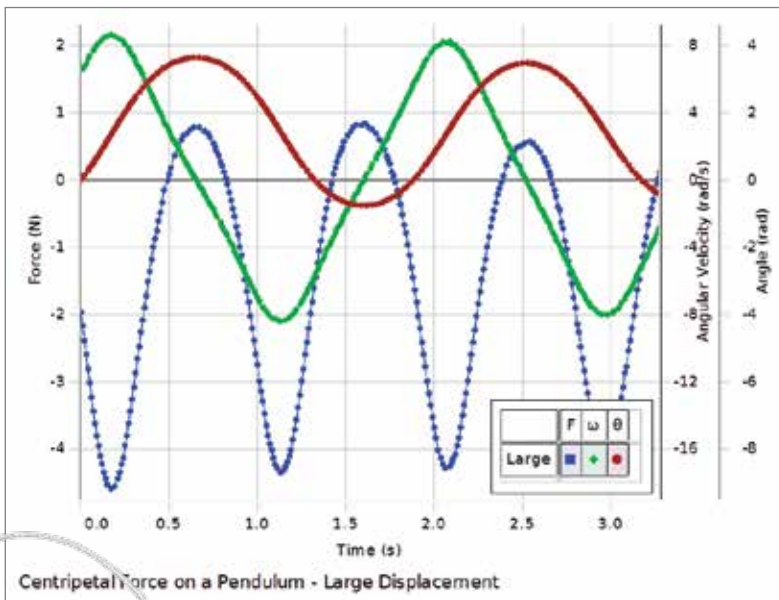

Students explore the relationship between mass, radius of rotation, angular velocity, and centripetal force. By continuously measuring the force and angular velocity, students see not just peak values but also how these change during the entire motion of the pendulum. Students explore sources of error and magnitude of error.

*Pendulum is pulled back by hand and then released.*

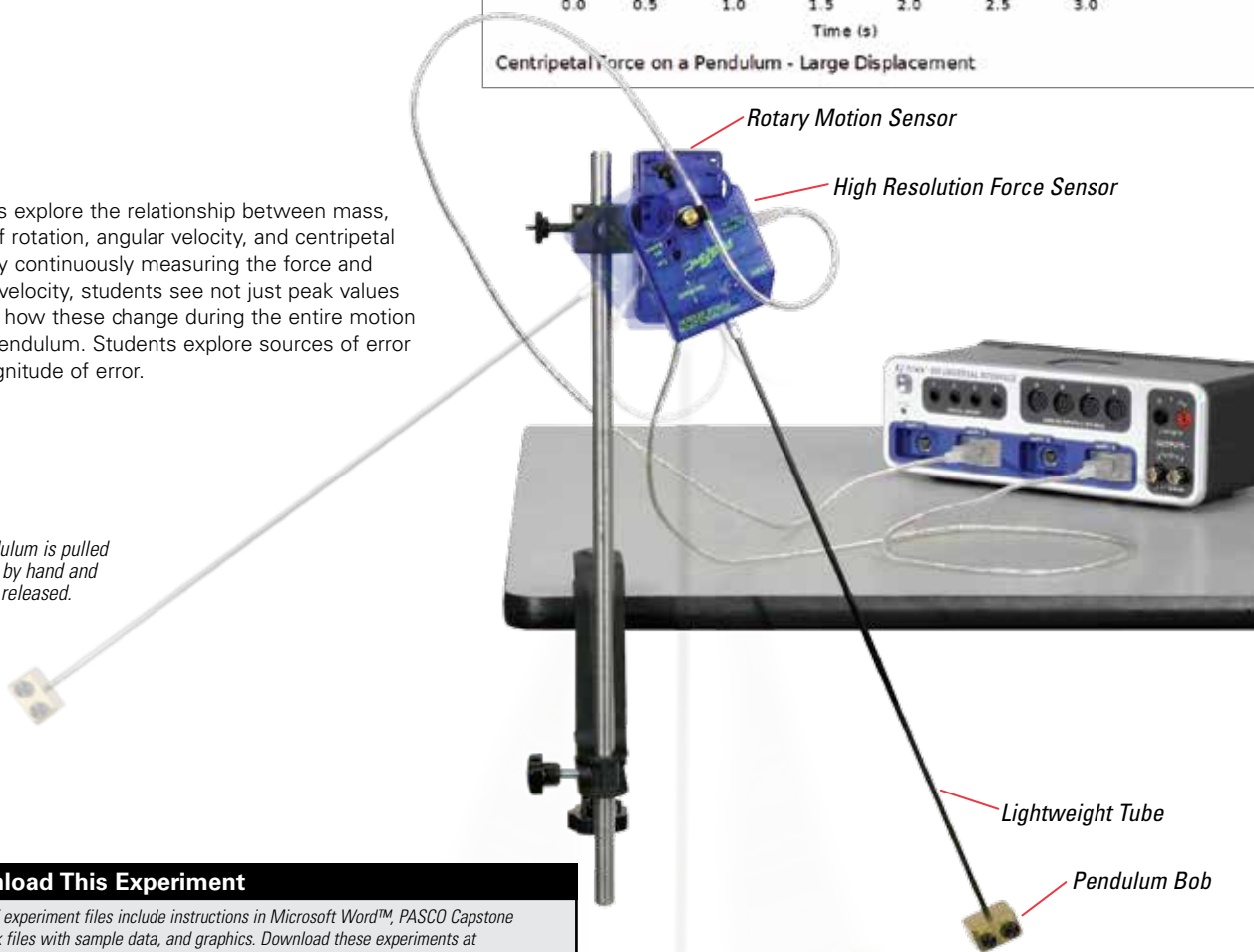

### Download This Experiment

The FREE experiment files include instructions in Microsoft Word™, PASCO Capstone workbook files with sample data, and graphics. Download these experiments at [www.pasco.com/CapstoneExperiments](http://www.pasco.com/CapstoneExperiments).

### Experiment Includes

- High Resolution Force Sensor PS-2189
- Rotary Motion Sensor PS-2120A
- Centripetal Force Pendulum ME-9821
- Aluminum Table Clamp ME-8995
- Steel Rod 45 cm ME-8736

### Order Information

Centripetal Force on a Pendulum .....EX-5505A

Required:

- 550 or 850 Universal Interface\* ..... pp. 10-12
- PASCO Capstone Software ..... pp. 18-20
- Balance or Scale ..... p. 186

\* This experiment can be performed using the 550 or 850 Universal Interface or any PASPORT interface with two ports.

# Centripetal Force

Designed for use with the 850 Universal Interface

EX-5506

## Concept:

### ► How centripetal force depends on radius, mass, and speed

Students explore the relationship between mass, radius of rotation, tangential speed, and centripetal force. By continuously measuring the force as the speed is varied, students clearly see the effect of speed on the centripetal force. The effect of changing the mass or radius is also investigated.

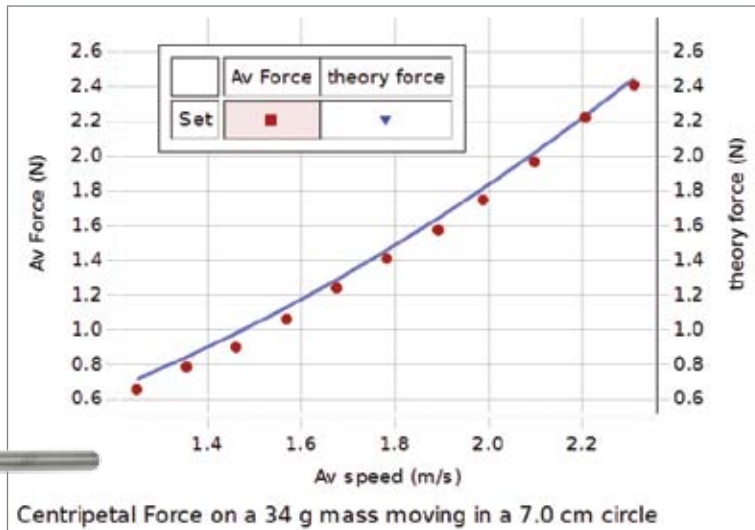
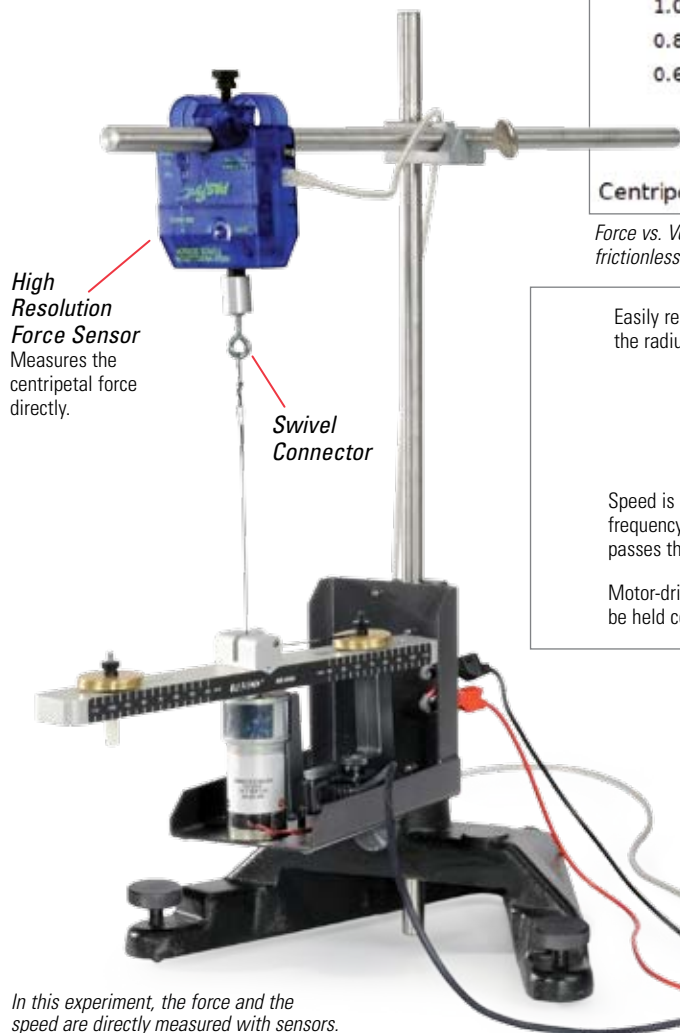

Force vs. Velocity data is shown above with a solid line representing the theoretical frictionless case.

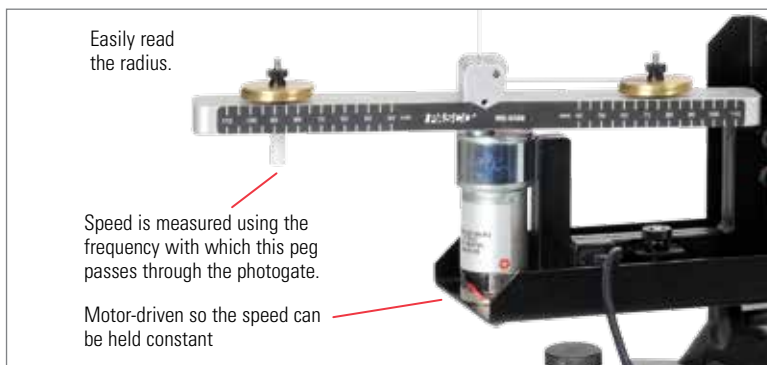

## Experiment Includes

- Centripetal Force Apparatus ME-8088
- High Resolution Force Sensor PS-2189
- Photogate Head ME-9498A
- Large Rod Base ME-8735
- 90 cm Steel Rod ME-8738
- Multi-Clamp ME-9507
- 45 cm Steel Rod ME-8736
- Banana Plug Cord-Red (5 pack) SE-9750

## Download This Experiment

The FREE experiment files include instructions in Microsoft Word™, PASCO Capstone workbook files with sample data, and graphics. Download these experiments at [www.pasco.com/CapstoneExperiments](http://www.pasco.com/CapstoneExperiments).

## Order Information

Centripetal Force .....EX-5506  
 Required:  
 850 Universal Interface..... p. 12  
 PASCO Capstone Software..... pp. 18-20

# Mechanics

## Sliding Friction

EX-5508

### Concepts:

- ▶ Relationship between frictional force and normal force
- ▶ Coefficients of friction (kinetic and static)

Designed for use with any of the following:

- ▶ 850 Universal Interface
- ▶ 550 Universal Interface
- ▶ Any PASPORT interface with 2 ports

In this experiment, students use a High Resolution Force Sensor to discover frictional forces and their effect on the motion of an object. In addition, the coefficients of friction for various surface combinations can be empirically determined.



Students pull the friction tray from rest to a constant velocity to measure both static and kinetic friction.

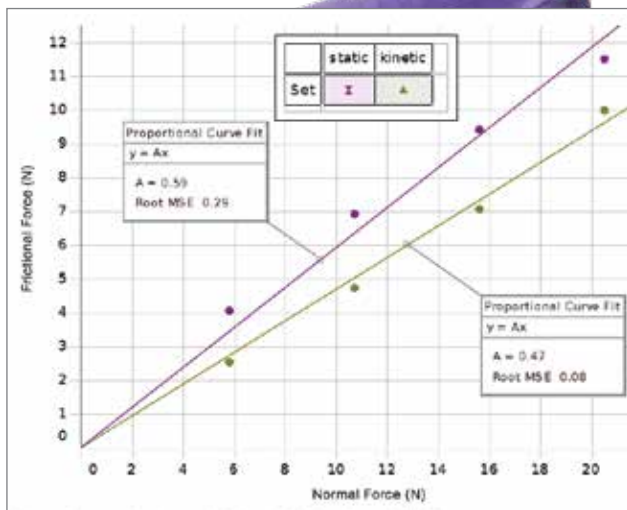

Students create a graph of frictional force vs. normal force to find the coefficients of static and kinetic friction.

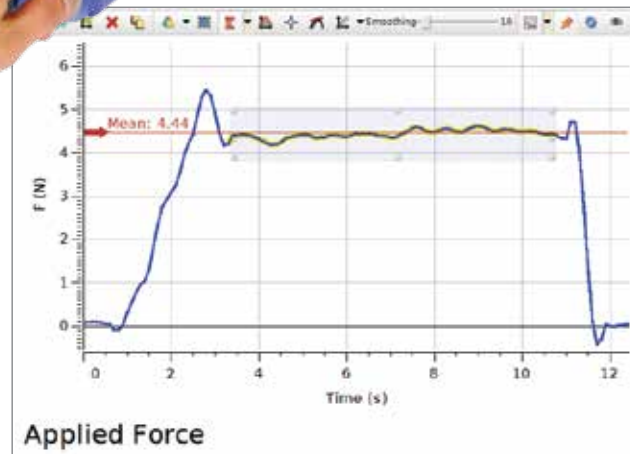

The peak of the graph represents the maximum static frictional force. Once the friction tray begins to move, the kinetic frictional force is evident on the graph.

### Download This Experiment

The FREE experiment files include instructions in Microsoft Word™, PASCO Capstone workbook files with sample data, and graphics. Download these experiments at [www.pasco.com/CapstoneExperiments](http://www.pasco.com/CapstoneExperiments).

### Order Information

Sliding Friction..... EX-5508

#### Required:

550 or 850 Universal Interface\* ..... pp. 12-14  
 PASCO Capstone Software ..... pp. 18-20

\* This experiment can be performed using the 550 or 850 Universal Interface or any PASPORT interface with two ports.

### Experiment Includes

- Discover Friction Accessory ME-8574
- High Resolution Force Sensor PS-2189
- Motion Sensor PS-2103A
- 500 g Cart Masses (4) ME-6757
- Physics String SE-8050

## Impulse

EX-5509A

- ▶ Designed for use with the Smart Cart
- ▶ No interface required

### Concepts:

- ▶ Impulse: change in momentum
- ▶ Impulse: area under a force versus time curve
- ▶ Different shaped force curves for elastic and inelastic collisions

In this experiment, the impulse on a cart is determined in two ways: by measuring the change in velocity and by finding the area under a Force versus Time curve.

A Smart Cart runs down a slightly inclined track with its Force Sensor equipped with either a clay bumper, spring bumper, or magnetic bumper. The cart collides with the endstop. To determine the change in momentum (impulse), the velocities before and after the collision are recorded using the Smart Cart's encoder. To confirm the impulse, the force versus time is plotted and the impulse is determined by finding the area under the curve.

Different shaped curves of force versus time are obtained for the different bumpers. The spring and magnetic bumpers result in nearly elastic collisions, while the clay produces a completely inelastic collision. The area under the clay force curve is half the area under the spring or magnetic force curves because the cart does not rebound in the clay collision.

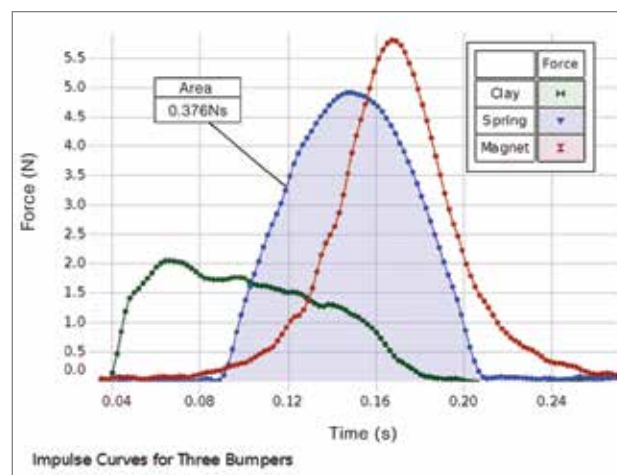

The force versus time is shown for three different bumpers: clay bumper in green, spring bumper in blue, and magnetic bumper in red.

The impulse of a collision is determined by two methods.



Magnetic, Spring, and Clay Bumpers

### PASCO Advantage

Since the PASCO Smart Cart is capable of measuring both force and velocity, it eliminates the need for any external sensor. No interface is required. No wires interfere with the motion because the Smart Cart transmits the data over Bluetooth® 4.0.

### Download This Experiment

The FREE experiment files include instructions in Microsoft Word™, PASCO Capstone workbook files with sample data, and graphics. Download these experiments at [www.pasco.com/CapstoneExperiments](http://www.pasco.com/CapstoneExperiments).

### Experiment Includes

- Force Sensor Bracket ME-6622
- PAScar Cart Mass (2) ME-6757A
- Smart Cart (Red) ME-1240
- Dynamics Track Endstops (set of 2) ME-8971
- Dynamics Track Feet (2) ME-8972
- 1.2 m Aluminum Dynamics Track ME-9493

### Order Information

- Impulse ..... EX-5509A
- Required:**
- Bluetooth 4.0 enabled computer
- PASCO Capstone Software ..... pp. 18-20
- Balance or Scale ..... p. 186

# Mechanics

## Conservation of Momentum

EX-5510B

- ▶ Designed for use with 2 Smart Carts
- ▶ No interface required

### Concepts:

- ▶ Conservation of momentum in elastic and inelastic collisions
- ▶ Kinetic energy not conserved in inelastic collisions
- ▶ Kinetic energy temporarily stored as magnetic potential energy during elastic collisions using magnetic bumpers

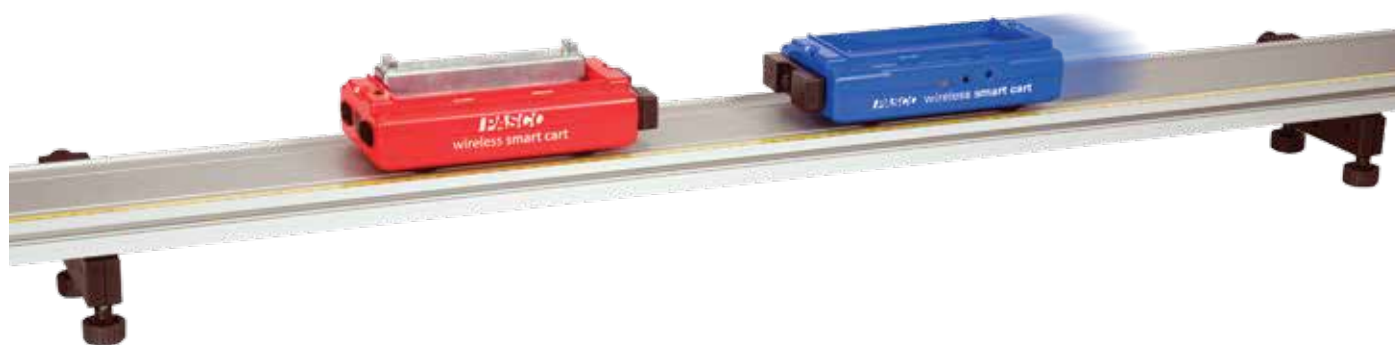

The total momentum and total energy of carts undergoing elastic and inelastic collisions are measured. The values before and after the collisions are compared to verify that momentum is conserved in all collisions, while energy is only conserved in elastic collisions.

Elastic and inelastic collisions are performed with two dynamics carts of different masses. Magnetic bumpers are used in the elastic collision and Velcro® bumpers are used in the completely inelastic collision. In both cases, momentum is conserved.

Cart velocities are recorded using the encoders inside the Smart Carts. A real-time graph of velocity versus time is obtained for each cart, clearly showing when the collision occurred. This enables the student to determine the cart velocities immediately before and after the collision.

The kinetic energy before and after the collision is also studied. Kinetic energy is not conserved for inelastic collisions. It is also demonstrated that kinetic energy momentarily decreases during the elastic collision and then returns to the original value after the collision.

### PASCO Advantage

The magnitude and direction of the velocity of each cart is recorded continuously throughout the collision, which eliminates the problem in older methods of positioning photogates too close or too far from the point of collision.

### Experiment Includes

- |                                |          |
|--------------------------------|----------|
| • 250 g Stackable Mass (2)     | ME-6757A |
| • Smart Cart (Red)             | ME-1240  |
| • Smart Cart (Blue)            | ME-1241  |
| • Dynamics Track End Stops (2) | ME-8971  |
| • Dynamics Track Feet (2)      | ME-8972  |
| • Starter Dynamics Track       | ME-9493  |

### Download This Experiment

The FREE experiment files include instructions in Microsoft Word™, PASCO Capstone workbook files with sample data, and graphics. Download these experiments at [www.pasco.com/CapstoneExperiments](http://www.pasco.com/CapstoneExperiments).

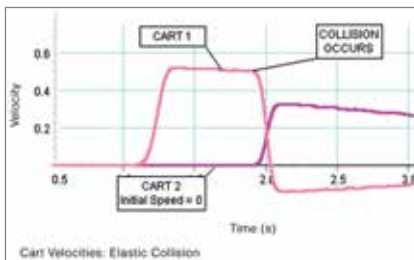

A real-time graph of velocity versus time is obtained for each cart, clearly showing when the elastic collision occurred.

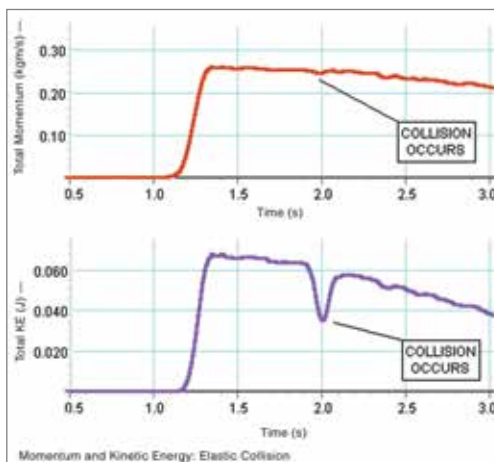

The top graph of the total momentum for the 2-cart system (as calculated in PASCO Capstone) shows no change throughout the elastic collision. The total kinetic energy, shown in the bottom graph, momentarily decreases during the collision because energy is stored as magnetic potential energy.

### Order Information

Conservation of Momentum.....EX-5510B

#### Required:

Bluetooth 4.0 enabled computer

PASCO Capstone Software ..... p. 18-20

Balance or Scale ..... p. 186

## Ballistic Pendulum

EX-5511A

### Concepts:

- ▶ Modern approach to a classic experiment
- ▶ View graph of entire pendulum swing
- ▶ Conservation of momentum
- ▶ Conservation of energy

PASCO's Rotary Motion Sensor is the heart of this modern approach to a classic physics experiment. The Mini Launcher (ME-6825A) fires a steel ball into the foam catcher of the Ballistic Pendulum Accessory (ME-6829) mounted on the Rotary Motion Sensor. The Rotary Motion Sensor measures the angular displacement of the pendulum and it is plotted in real-time in PASCO Capstone.

There is no need to catch the pendulum at its maximum height because the angle is continuously measured. Using the analysis tools in PASCO Capstone, students can find the maximum angle.

Using Conservation of Momentum and Conservation of Energy, students can determine the initial speed of the ball as it leaves the projectile launcher. The initial speed of the ball is confirmed by using two photogates to time the flight of the ball for a short distance.

Designed for use with any of the following:

- ▶ 850 Universal Interface
- ▶ 550 Universal Interface
- ▶ AirLink

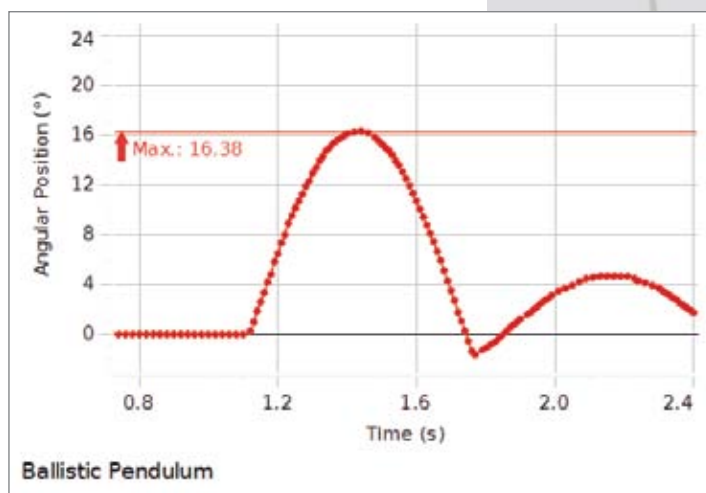

This graph of the angle of the pendulum versus time is plotted in real-time in PASCO Capstone. The maximum angle is displayed on the graph.



The ball is shot into a foam catcher at the end of a pendulum. The pendulum is mounted on a Rotary Motion Sensor to record the entire swing.

### Download This Experiment

The FREE experiment files include instructions in Microsoft Word™, PASCO Capstone workbook files with sample data, and graphics. Download these experiments at [www.pasco.com/CapstoneExperiments](http://www.pasco.com/CapstoneExperiments).

### Experiment Includes

- |                                    |          |
|------------------------------------|----------|
| • Rotary Motion Sensor             | PS-2120A |
| • Mini Launcher                    | ME-6825A |
| • Photogate Heads (2)              | ME-9498A |
| • Photogate Mounting Bracket       | ME-6821A |
| • Mini Launcher Ballistic Pendulum | ME-6829  |
| • Large "C" Clamp                  | SE-7285  |
| • 45 cm Steel Rod                  | ME-8736  |

### Order Information

Ballistic Pendulum..... EX-5511A  
**Required:**  
 550 or 850 Universal Interface\* ..... pp. 12 -14  
 PASCO Capstone Software ..... p. 18 -20  
 \* This experiment can be performed using the 550 or 850 Universal Interface or AirLink.

# Mechanics

## Conservation of Energy

EX-9935

### Concepts:

- ▶ Conservation of energy
- ▶ Centripetal acceleration
- ▶ Apparent weight

In this experiment, the Law of Conservation of Energy is verified by measuring the potential and kinetic energies for a car traveling over hills and loops on a curved track.

A car is started from rest on a variety of tracks (hills, valleys, loops, straight track). The speed of the car is measured at various points along the track using a photogate connected to a Smart Timer.

The potential energy is calculated from the measured height and the kinetic energy is calculated from the speed. The total energy is calculated for two points on the track and compared.

The height from which the car must be released from rest to just make it over the loop can be predicted from conservation of energy and the centripetal acceleration. Then the prediction can be tested on the roller coaster. If the car is released from the top of the hill so it easily makes it over the top of the loop, the speed of the car can be measured at the top of the loop and the centripetal acceleration as well as the apparent weight (normal force) on the car can be calculated.

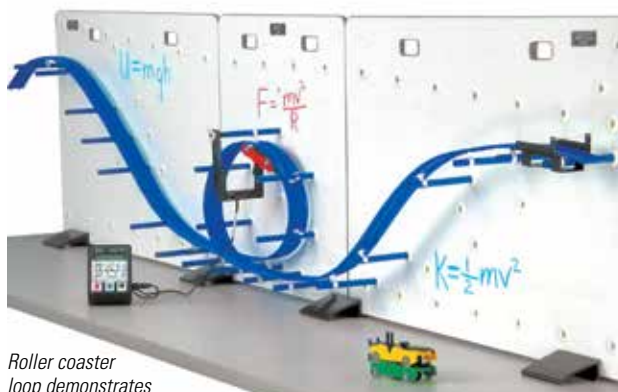

Roller coaster loop demonstrates conservation of energy.

### Experiment Includes

- Complete Roller Coaster System ME-9812
- Photogate Heads (2) ME-9498A
- Smart Timer ME-8930
- Conservation of Energy Experiment Manual

### PASCO Advantage

The Roller Coaster can be configured in many ways. The white board background is convenient for writing calculations or making marks for measuring heights. The PASCO Roller Coaster differs from conventional roller coaster toys in three ways:

- ▶ Speed and height of the Roller Coaster car can be easily measured
- ▶ Loss of energy due to friction is generally only about 5%
- ▶ Cars will withstand repeated drops to the floor



Conservation of energy for a car going over hills



Conservation of energy shows that the final speeds of these two cars are the same even though the red car takes much less time than the yellow car to reach the end of the track.



The different speeds of each of three linked cars as they go over the loop are measured using a photogate.

### To Download This Experiment

Search for EX-9935 at [www.pasco.com](http://www.pasco.com)

### Order Information

Conservation of Energy.....EX-9935

## Conservation of Energy II

EX-5512

### Concepts:

- ▶ Potential energy of a falling ball
- ▶ Kinetic energy of a falling ball
- ▶ Use different size balls to change friction

A ball is dropped from rest and its height and speed are recorded using a Motion Sensor. The ball's potential energy and kinetic energy are calculated at various points during the ball's fall.

The total energy of the ball is examined throughout the fall to determine if there is any change. Balls of different sizes are used to vary the amount of air friction, so that students can see that energy is not conserved when friction is appreciable.

Designed for use with any of the following:

- ▶ 850 Universal Interface
- ▶ 550 Universal Interface
- ▶ AirLink

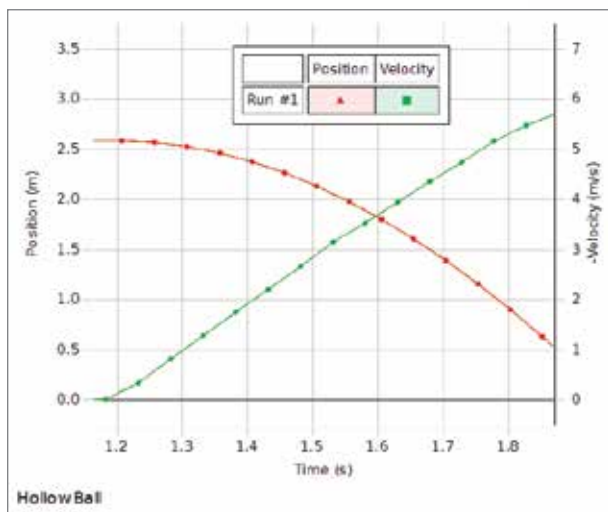

As the ball falls, its height and speed are recorded and displayed in PASCO Capstone Software.

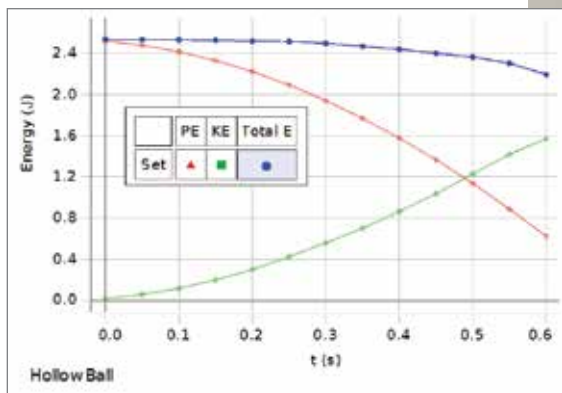

The height and speed of the ball at various points during the fall are used to calculate the potential energy and the kinetic energy. Note decrease in total energy for hollow ball near end of fall.

### Experiment Includes

- Motion Sensor
- Discover Freefall System
- Large Rod Base
- 120 cm Rod
- Multi Clamp
- 45 cm Rod
- Motion Sensor Guard

- PS-2103A
- ME-9889
- ME-8735
- ME-8741
- ME-9507
- ME-8736
- SE-7256



**Download This Experiment**

The FREE experiment files include instructions in Microsoft Word™, PASCO Capstone workbook files with sample data, and graphics. Download these experiments at [www.pasco.com/CapstoneExperiments](http://www.pasco.com/CapstoneExperiments).

**Order Information**

Conservation of Energy II .....EX-5512

*Required:*

550 or 850 Universal Interface\* ..... pp. 12-14

PASCO Capstone Software ..... pp. 18-20

\* This experiment can be performed using the 550 or 850 Universal Interface or AirLink.

# Mechanics

## Work Energy Theorem

EX-5513A

### Concepts:

- ▶ Kinetic energy
- ▶ Potential energy
- ▶ Work energy theorem
- ▶ Conservation of mechanical energy

Designed for use with any of the following:

- ▶ 850 Universal Interface
- ▶ 550 Universal Interface
- ▶ Any PASPORT interface with 2 ports

The total work done on an object is compared with the change in kinetic energy of the object. Using a High Resolution Force Sensor and a Motion Sensor, students record and display the force as a function of position. The work done is the area under the force vs. position plot. At any point during the experiment, kinetic energy is calculated from the velocity measured with the Motion Sensor. Students explore the meaning of dissipative forces.

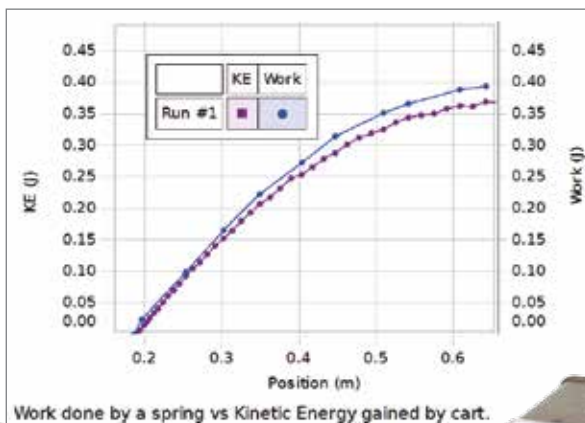
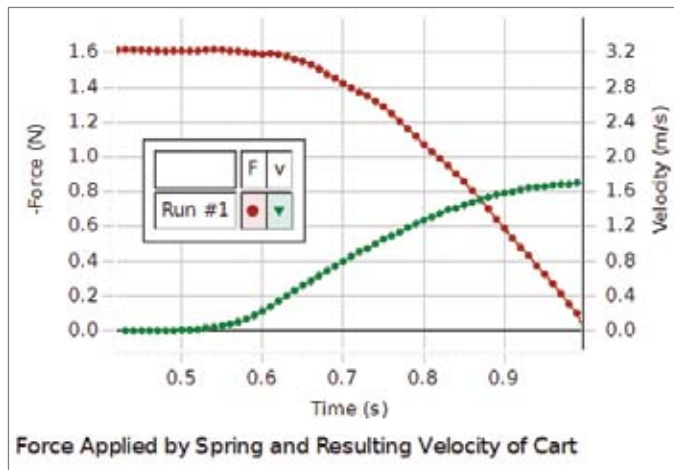

*Work done by friction and ignoring the rotational kinetic energy of the wheels cause the cart kinetic energy to be approximately 5% low.*

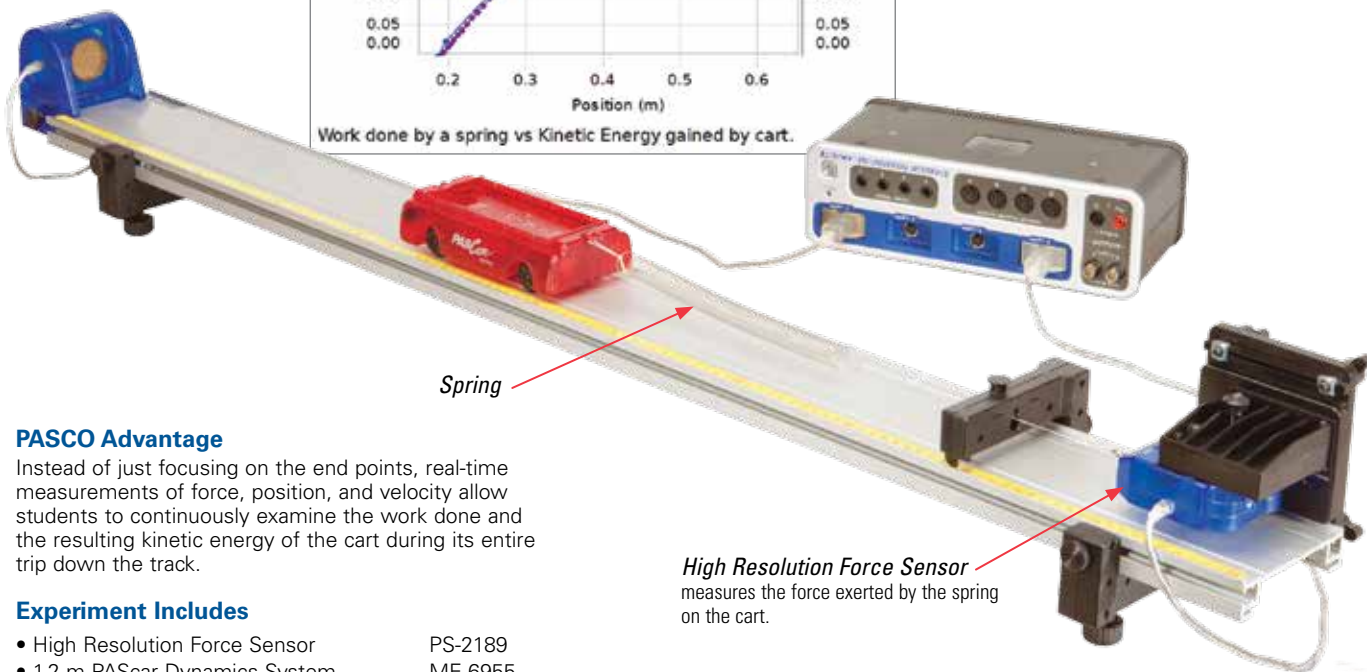

### PASCO Advantage

Instead of just focusing on the end points, real-time measurements of force, position, and velocity allow students to continuously examine the work done and the resulting kinetic energy of the cart during its entire trip down the track.

### Experiment Includes

- High Resolution Force Sensor PS-2189
- 1.2 m PAScar Dynamics System ME-6955
- Motion Sensor PS-2103A
- Force Bracket ME-6622
- Dynamics Track Spring Set ME-8999
- Braided Physics String SE-8050

### Order Information

Work Energy Theorem .....EX-5513A  
**Required:**  
 550 or 850 Universal Interface\* ..... pp. 12-14  
 PASCO Capstone Software ..... pp. 18-20  
 Balance or Scale ..... p. 186  
 \* This experiment can be performed using the 550 or 850 Universal Interface or any PASPORT interface with two ports.

**Download This Experiment**  
 The FREE experiment files include instructions in Microsoft Word™, PASCO Capstone workbook files with sample data, and graphics. Download these experiments at [www.pasco.com/CapstoneExperiments](http://www.pasco.com/CapstoneExperiments).

## Universal Gravitational Constant

EX-5550

### Concepts:

- ▶ Measure the Universal Gravitational Constant in less than three hours!
- ▶ Recreate Cavendish's historical experiment
- ▶ Uses PASCO Capstone Video Analysis

The attraction between a pair of small tungsten spheres and a pair of larger tungsten spheres is measured by the torsion of a beryllium ribbon. The large spheres are placed close to the small spheres and allowed to equilibrate. A laser is reflected from a mirror on the beryllium ribbon and shown on a screen or wall. The large spheres are then rotated through an angle to produce torque on the ribbon. The mirror rotates with the ribbon, so the laser reflection on the screen or wall is displaced. The displacement of the laser reflection is measured to find "G".

### PASCO Advantage

For the first time, the measurement of G using the Cavendish Balance can actually be performed in a 3-hour lower division physics laboratory! Data collection is done using a webcam to video two periods of the oscillation for both ball positions in less than 45 minutes. The video data may then be transferred to the lab groups for analysis using the video analysis capability of PASCO Capstone. Fitting a damped sine curve to the video data allows an extremely precise determination of period of oscillation and where the final equilibrium positions would be. When analysis of small effects inherent in the method is included, an accuracy of better than 2% is possible.



At left, the USB Camera Microscope records the oscillation of the laser beam.

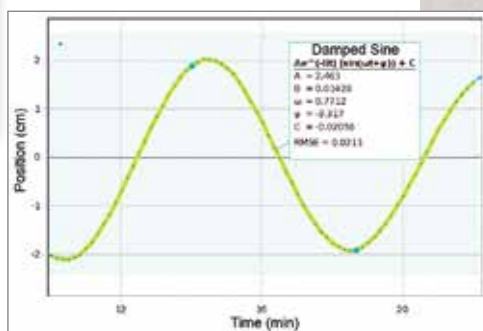

In PASCO Capstone, a damped sine fit is applied to the data to determine the equilibrium point.

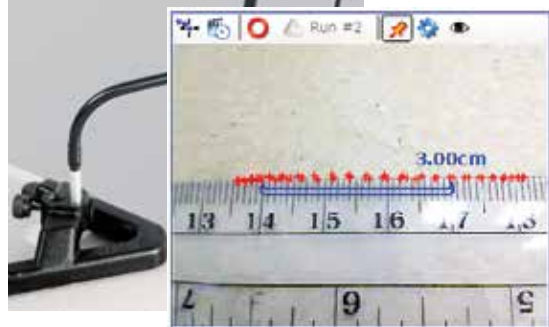

This is a screenshot of the video analysis points (red plus signs) in PASCO Capstone.



### Experiment Includes

- |                                 |          |
|---------------------------------|----------|
| • Gravitational Torsion Balance | AP-8215A |
| • X-Y Adjustable Diode Laser    | OS-8526A |
| • Large Rod Base                | ME-9735  |
| • USB Camera Microscope         | PS-2343  |
| • Polarizer Set                 | OS-8473  |
| • Rods and Clamps               |          |

**NOTE:** No interface is required.

### Order Information

Universal Gravitational Constant ..... EX-5550  
 Required:  
 PASCO Capstone Software ..... pp. 18-20  
 Transparent ruler and Meter Stick

### To Download This Experiment

Search for EX-5550 at [www.pasco.com](http://www.pasco.com)

# Mechanics

## Archimedes' Principle

EX-9909

### Concepts:

- ▶ Archimedes' Principle
- ▶ Density
- ▶ Buoyant force

Archimedes' Principle states that the buoyant force on a submerged object is equal to the weight of the fluid that is displaced by the object.

The buoyant force on several objects is measured by weighing the water displaced by a submerged object. The buoyant force is also determined by measuring the difference between the object's weight in air and its apparent weight in water.

Some of the objects have the same density, some have the same volume, and some have the same mass. The density of each object is measured and the dependence of the buoyant force on density, mass, and volume is explored.



The buoyant force is measured by weighing the water displaced by the object.



The mass and volume are measured to determine the dependence of the buoyant force on mass, volume, and density.

### Experiment Includes

- Density Set ME-8569
- Overflow Can SE-8568
- Rod Base ME-8735
- 45 cm Steel Rod ME-8736
- Physics String SE-8050
- Triple-Beam Balance SE-8707
- Stainless Steel Calipers SF-8711
- 1000 ml Beaker
- 100 ml Beaker
- 50 ml Graduated Cylinder
- Archimedes' Principle Experiment Manual

### PASCO Advantage

The provided objects have related volumes, masses, and densities to demonstrate that only the volume of water displaced affects the buoyant force.

### To Download This Experiment

Search for EX-9909 at [www.pasco.com](http://www.pasco.com)

### Order Information

Archimedes' Principle..... EX-9909

## Rotational Inertia

EX-5516A

### Concepts:

- ▶ Rotational inertia of a ring and a disk
- ▶ Torque

In this experiment, the rotational inertias of a ring and a disk are determined by applying a torque to the object and measuring the resulting angular acceleration.

A known torque is applied to the pulley on the Rotary Motion Sensor, causing a disk and ring to rotate. The resulting angular acceleration is measured using the slope of a graph of angular velocity versus time. The rotational inertia of the disk and ring combination is calculated from the torque and the angular acceleration. The procedure is repeated for the disk alone to find the rotational inertias of the ring and disk separately.

Designed for use with any of the following:

- ▶ 850 Universal Interface
- ▶ 550 Universal Interface
- ▶ AirLink



The Rotary Motion Sensor provides a sturdy, low-friction rotational platform for the Ring and Disk, in addition to measuring the resulting angular acceleration.

A known torque is applied to the ring and disk by the weight hanging over the pulley. The rotational inertia of the ring and disk are determined from the resulting angular acceleration. The procedure is repeated for the disk alone.

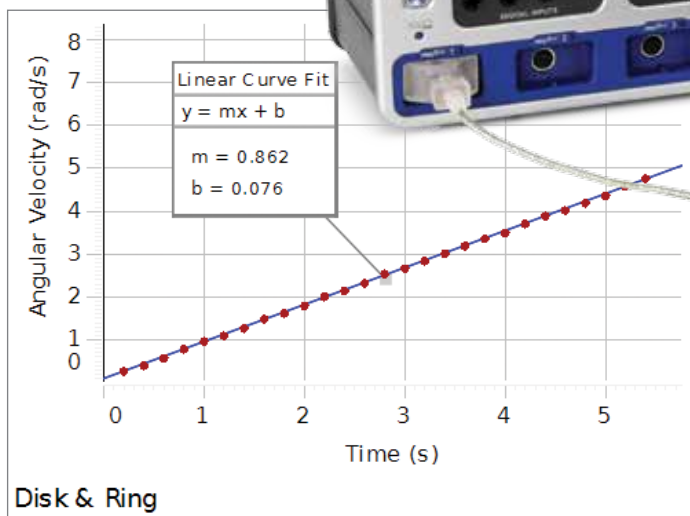

The rotational inertia of the ring and disk is calculated from the angular acceleration obtained from the slope of this angular velocity versus time graph.

### PASCO Advantage

Friction can be neglected in this compact setup. The Rotary Motion Sensor is a versatile tool that can be used in a variety of other experiments.

### Experiment Includes

- Large Rod Stand ME-8735
- 90 cm Long Steel Rod ME-8738
- Mini-Rotational Accessory CI-6691
- Mass Set (5 g resolution) ME-8979
- Rotary Motion Sensor PS-2120A

### Download This Experiment

The FREE experiment files include instructions in Microsoft Word™, PASCO Capstone workbook files with sample data, and graphics. Download these experiments at [www.pasco.com/CapstoneExperiments](http://www.pasco.com/CapstoneExperiments).

### Order Information

Rotational Inertia ..... EX-5516A

#### Required:

- 550 or 850 Universal Interface\* ..... pp. 12-14
- PASCO Capstone Software ..... pp. 18-19
- Balance or Scale ..... p. 186
- Calipers ..... SE-8710 p. 182

\* This experiment can be performed using the 550 or 850 Universal Interface or AirLink.

# Mechanics

## Physical Pendulum

EX-5518A

### Concepts:

- ▶ Parallel Axis Theorem
- ▶ Period of a physical pendulum
- ▶ Computer modeling of a system
- ▶ Rotational inertia

In this experiment, the period of a physical pendulum, a narrow bar, is determined as a function of the distance of the pivot from the center of mass. A computer model of the system is developed, which allows the student to vary the physical parameters of the model (gravity, length, c.m. position) to match the data. This makes it possible to obtain values for the physical parameters without direct measurement.

A second experiment verifies the parallel axis theorem. It also uses superposition to find the rotational inertia of a disk with an off axis circular hole.

Designed for use with any of the following:

- ▶ 850 Universal Interface
- ▶ 550 Universal Interface
- ▶ AirLink

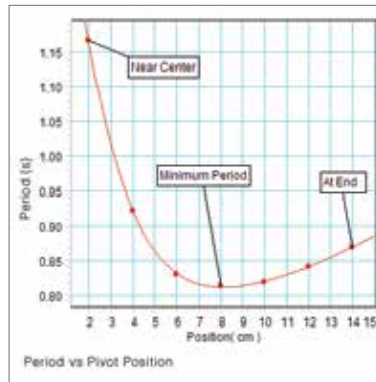

The Pendulum Bar has holes spaced at 2 cm intervals. A graph of oscillation period vs. pivot hole position shows that there is a unique placement that gives a minimum period. This location can be verified using calculus.



Apply a known torque and measure the angular acceleration to calculate the moment of inertia of the object. Multiple holes in the plate allow investigation of the Parallel Axis Theorem.

Center hole is at center of mass.



Unique design allows pivot exactly at the edge. Measure the period of the thick ring oscillating at either the inner or outer radius.



### Experiment Includes

- Large Rod Stand ME-8735
- 45 cm Long Steel Rod ME-8736
- Physical Pendulum Set ME-9833
- Rotary Motion Sensor PS-2120A

### Order Information

Physical Pendulum ..... EX-5518A

Required:

550 or 850 Universal Interface\* ..... pp. 12-14

PASCO Capstone Software ..... pp. 18-20

\* This experiment can be performed using the 550 or 850 Universal Interface or AirLink.

### Download This Experiment

The FREE experiment files include instructions in Microsoft Word™, PASCO Capstone workbook files with sample data, and graphics. Download these experiments at [www.pasco.com/CapstoneExperiments](http://www.pasco.com/CapstoneExperiments).

## Conservation of Angular Momentum

EX-5517A

Designed for use with any of the following:

- ▶ 850 Universal Interface
- ▶ 550 Universal Interface
- ▶ AirLink

### Concepts:

- ▶ Conservation of angular momentum during collisions
- ▶ Easy determination of before and after points
- ▶ Calculation of energy lost during collision

The study of conservation of angular momentum during collisions is easy and fast using this system based on the Rotary Motion Sensor. The angular velocity of the spinning disk is graphed in real-time as a non-rotating ring is dropped onto it.

*As a non-rotating ring is dropped onto a rotating disk, the angular velocity decreases to about 1/6th of its initial value since the ring has a large rotational inertia compared to the disk.*



*The Rotary Motion Sensor provides a sturdy, low-friction rotational platform for the Ring and Disk, in addition to measuring the resulting change in angular velocity.*

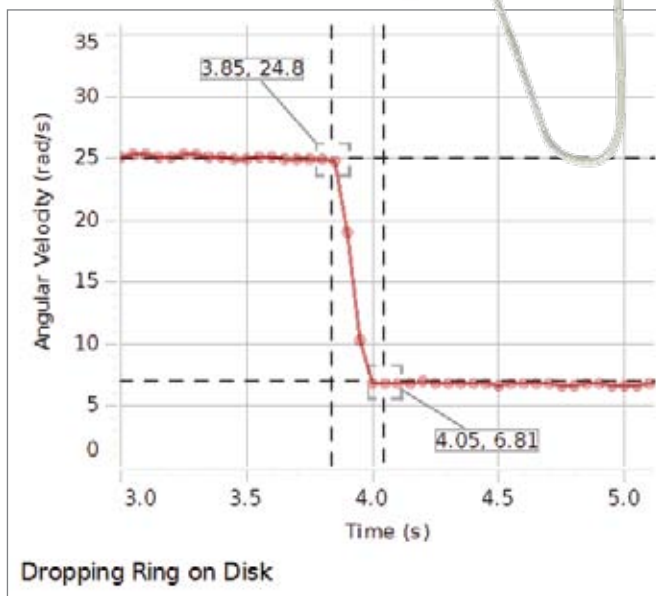

### PASCO Advantage

It is easy to measure the rotational speeds just before and after the collision since the entire collision is visible in the graph.

The rotational inertias of the ring and disk are calculated using the mass and dimensions of each. Then the total angular momentum before the collision is compared to the total angular momentum after the collision to show that it does not change.

The total kinetic energy before and after the collision is calculated to show the amount of energy lost during the inelastic collision.

### Experiment Includes

- Rotary Motion Sensor PS-2120A
- Rotational Accessory CI-6691
- Calipers SF-8711
- Large Rod Stand ME-8735
- 45 cm Long Steel Rod ME-8736

### Order Information

Conservation of Angular Momentum ..... EX-5517A

*Required:*

550 or 850 Universal Interface\* ..... pp. 12-14

PASCO Capstone Software ..... pp. 18-20

Balance or Scale ..... p. 186

\* This experiment can be performed using the 550 or 850 Universal Interface or AirLink.

### Download This Experiment

The FREE experiment files include instructions in Microsoft Word™, PASCO Capstone workbook files with sample data, and graphics. Download these experiments at [www.pasco.com/CapstoneExperiments](http://www.pasco.com/CapstoneExperiments).

# Oscillations

## Variable-g Pendulum

EX-5519A

### Concepts:

- ▶ Period of a simple pendulum
- ▶ Effect of decreasing “g” on the pendulum period
- ▶ Large amplitude period
- ▶ Shape of displacement, velocity, and acceleration curves for large amplitude

Designed for use with any of the following:

- ▶ 850 Universal Interface
- ▶ 550 Universal Interface
- ▶ AirLink

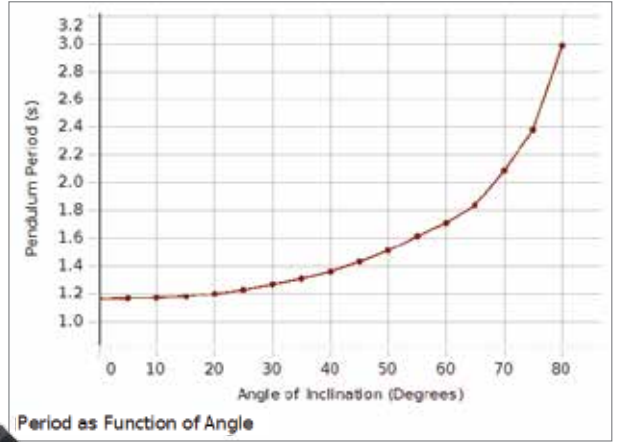

The period of the Variable-g Pendulum is plotted as a function of the angle of inclination to show the dependence of the period on g.

This experiment explores the dependence of the period of a simple pendulum on the acceleration due to gravity and on the length and amplitude of the pendulum.

A simple rigid pendulum consists of a 35 cm long lightweight aluminum tube with masses at the end, mounted on a Rotary Motion Sensor. The pendulum is constrained to oscillate in a plane tilted at an angle from the vertical. This effectively reduces the acceleration due to gravity because the restoring force is decreased.



The period is measured for varying angles, simulating changing the acceleration due to gravity for the pendulum.

The Adjustable Angle Clamp makes it easy to adjust the angle from zero to 90 degrees, thus varying “g” from 9.8 m/s<sup>2</sup> to zero.

### Experiment Includes

- Large Rod Stand ME-8735
- 45 cm Long Steel Rod ME-8736
- Angle Indicator ME-9495A
- Adjustable Angle Clamp ME-8744
- Pendulum Accessory ME-8969
- Rotary Motion Sensor PS-2120A

### PASCO Advantage

The rigid pendulum can be assumed to be a simple pendulum: the actual period is approximately 99% of the period of a simple pendulum of the same length.

### Order Information

- Variable-g Pendulum..... EX-5519A
- Required:
- 550 or 850 Universal Interface\*..... pp. 12-14
- PASCO Capstone Software..... pp. 18-20
- \* This experiment can be performed using the 550 or 850 Universal Interface or AirLink.

### Download This Experiment

The FREE experiment files include instructions in Microsoft Word™, PASCO Capstone workbook files with sample data, and graphics. Download these experiments at [www.pasco.com/CapstoneExperiments](http://www.pasco.com/CapstoneExperiments).

## Large Amplitude Pendulum

EX-5520A

### Concepts:

- ▶ Low amplitude approximation for the pendulum period
- ▶ Large amplitude period
- ▶ Shape of displacement, velocity, and acceleration curves for large amplitude

This experiment explores the dependence of the period of a simple pendulum on the amplitude of the oscillation. Also, the displacement, velocity, and acceleration for large amplitude are plotted versus time to show the difference from the sinusoidal motion of low amplitude oscillations.

A rigid pendulum consists of a 35 cm long lightweight (28 g) aluminum tube with a 75 g mass on each end. The center of the tube is mounted on a Rotary Motion Sensor. One of the masses is slightly closer to the center than the other mass, so the pendulum will oscillate slowly. Students will have time to view the motion of the pendulum, while also watching the real-time graph of displacement, velocity, and acceleration versus time.

The period is measured as a function of the amplitude of the pendulum and compared to theory.

Designed for use with any of the following:

- ▶ 850 Universal Interface
- ▶ 550 Universal Interface
- ▶ AirLink

*The rigid pendulum can be displaced 180 degrees and has a long period because of the offset masses.*

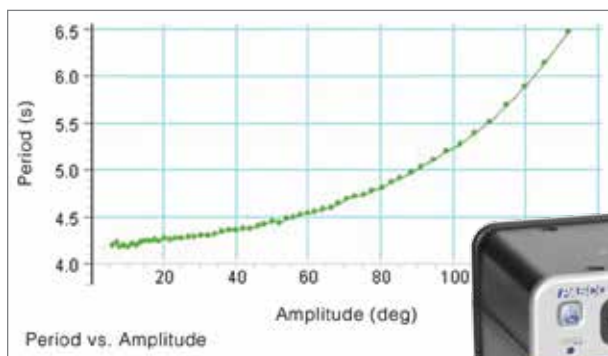

*The pendulum period is plotted versus amplitude.*

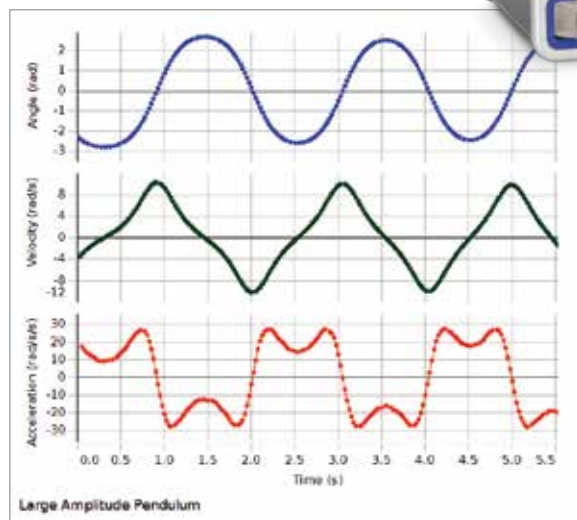

*Graphs of angular displacement, velocity, and acceleration versus time are displayed for a pendulum oscillating with large amplitude.*



### PASCO Advantage

PASCO Capstone has a period function that can be plotted versus the amplitude in real-time as the pendulum's oscillation damps out. The pendulum is initially displaced almost 180 degrees and then, as the amplitude decreases because of friction, the period is automatically recorded as a function of amplitude.

### Experiment Includes

- Small "A" Base ME-8976
- 25 cm Long Threaded Steel Rod ME-8988
- Pendulum Accessory ME-8969
- Rotary Motion Sensor PS-2120A

### Order Information

Large Amplitude Pendulum.....EX-5520A

*Required:*

550 or 850 Universal Interface\* ..... pp. 12-14

PASCO Capstone Software ..... pp. 18-20

\* This experiment can be performed using the 550 or 850 Universal Interface or AirLink.

### Download This Experiment

The FREE experiment files include instructions in Microsoft Word™, PASCO Capstone workbook files with sample data, and graphics. Download these experiments at [www.pasco.com/CapstoneExperiments](http://www.pasco.com/CapstoneExperiments).

# Oscillations

## Driven Damped Harmonic Oscillator

Designed for use with the 850 Universal Interface

EX-5522A

### Concepts:

- ▶ Resonance curves for an oscillator: amplitude vs. frequency
- ▶ Resonant frequency
- ▶ Period of a pendulum
- ▶ Effect of magnetic damping on shape of resonance curve
- ▶ Phase difference between oscillator and driver at low, resonant, and high frequencies

In this experiment, the resonance of a driven damped harmonic oscillator is examined by plotting the oscillation amplitude versus frequency for various amounts of damping.

The oscillator consists of an aluminum disk with a pulley connected to two springs by a string. The angular positions and velocities of the disk and the driver are recorded as a function of time using two Rotary Motion Sensors. The amplitude of the oscillation is plotted versus the driving frequency for different amounts of magnetic damping. Increased damping is provided by moving an adjustable magnet closer to the aluminum disk.

### PASCO Advantage

The combination of PASCO Capstone Software and the 850 Universal Interface has the power to sweep through the driver frequencies and the capability to plot the amplitude versus the driver frequency in real-time.

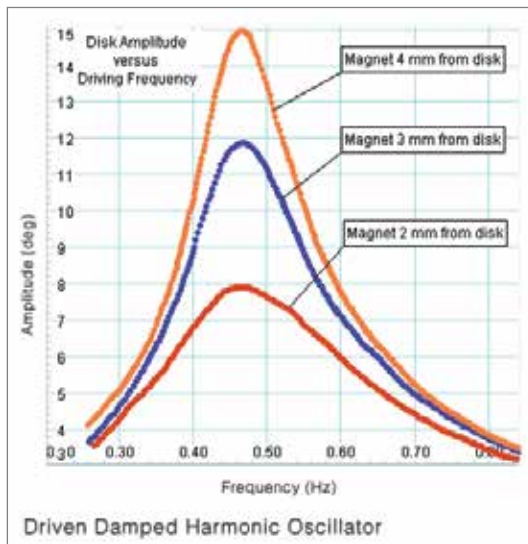

*This graph shows the resonance curves (amplitude vs. frequency) for three different settings of magnetic damping.*

### Experiment Includes

- |                                   |          |
|-----------------------------------|----------|
| • Rotary Motion Sensor (2)        | PS-2120A |
| • Mechanical Oscillator/Driver    | ME-8750  |
| • Chaos/Driven Harmonic Accessory | CI-6689A |
| • Large Rod Stand                 | ME-8735  |
| • 120-cm Long Steel Rod (2)       | ME-8741  |
| • 45-cm Long Steel Rod            | ME-8736  |
| • Multi-Clamps (2)                | ME-9507  |
| • Physics String                  | SE-8050  |

### Download This Experiment

The FREE experiment files include instructions in Microsoft Word™, PASCO Capstone workbook files with sample data, and graphics. Download these experiments at [www.pasco.com/CapstoneExperiments](http://www.pasco.com/CapstoneExperiments).

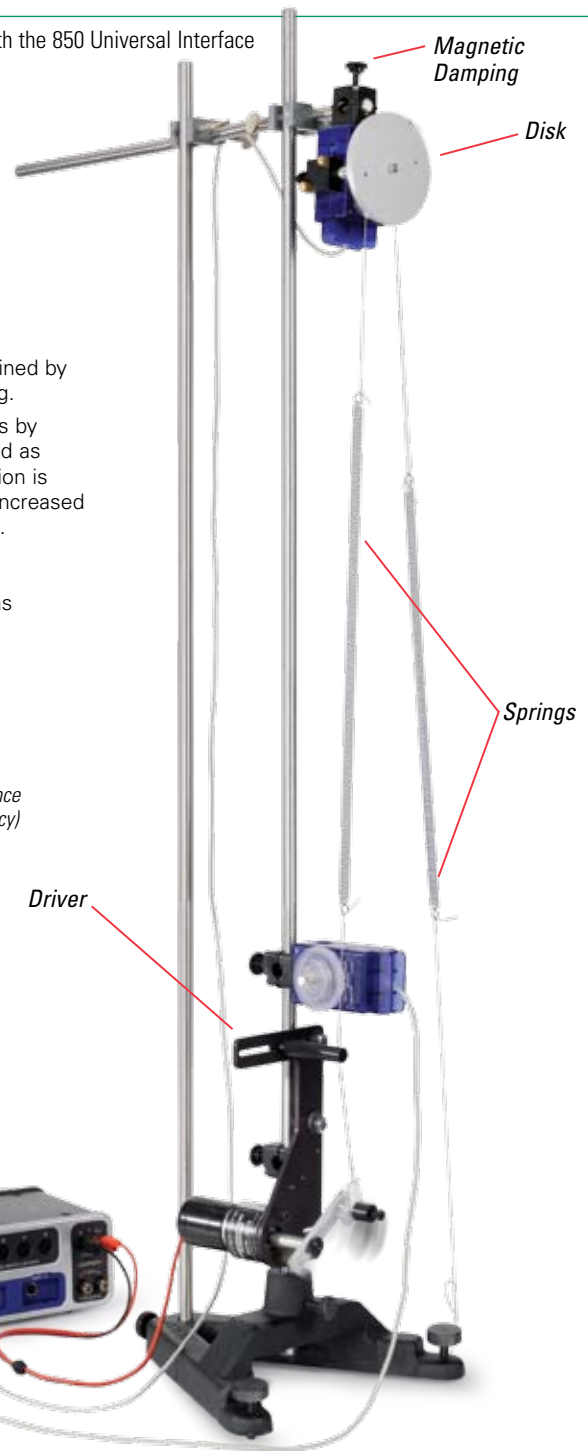

*The magnetically damped oscillator is driven by a sinusoidal mechanical driver.*

### Order Information

Driven Damped Harmonic Oscillator.....	EX-5522A
<i>Required:</i>	
850 Universal Interface.....	p. 12
PASCO Capstone Software.....	pp. 18-20
Hooked Mass Set.....	p. 187
Calipers.....	SE-8710 p. 182

## Chaos

Designed for use with the 850 Universal Interface

EX-5523A

### Concepts:

- ▶ Nonlinear oscillator
- ▶ Phase space
- ▶ Chaotic motion
- ▶ Poincare plot

The chaotic behavior of a driven nonlinear pendulum is explored by graphing its motion in phase space and by making a Poincare plot. These plots are compared to the motion of the pendulum when it is not chaotic.

The oscillator consists of an aluminum disk connected to two springs. A point mass on the edge of the aluminum disk makes the oscillator nonlinear. The frequency of the sinusoidal driver can be varied to investigate the progression from predictable motion to chaotic motion. Magnetic damping can be adjusted to change the character of the chaotic motion. The angular position and velocity of the disk are recorded as a function of time using a Rotary Motion Sensor. A real-time phase plot is made by graphing the angular velocity versus the displacement angle of the oscillation.

The Poincare plot is also graphed in real-time, superimposed on the phase plot. This is achieved by recording the point on the phase plot once every cycle of the driver arm as the driver arm blocks a photogate.

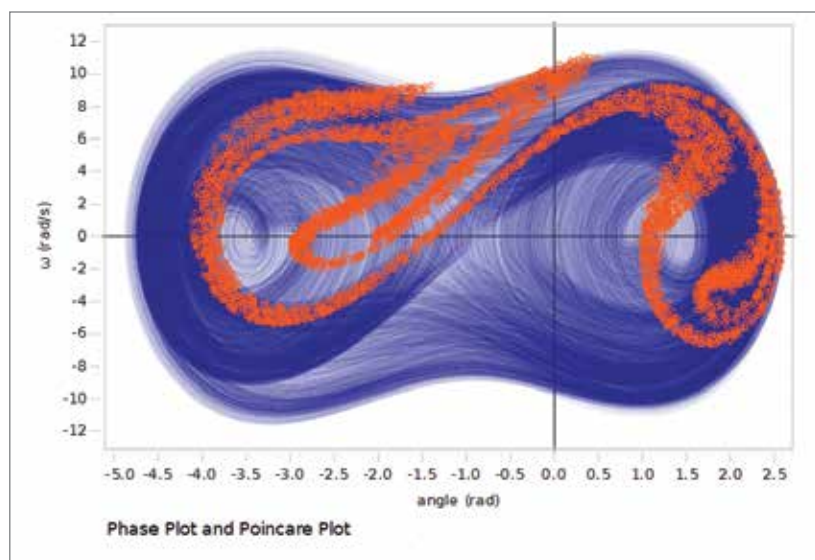

*A graph in phase space and a Poincare plot are obtained to study the chaotic motion of this nonlinear oscillator.*

The Poincare plot (in orange) shows the pendulum's velocity versus position once per revolution of the driver. The purple background is the phase plot.

This phase plot (angular velocity versus angle) is graphed in PASCO Capstone using partial opacity, so the trace gets darker as it traces back over itself.

### Experiment Includes

- Large Rod Stand ME-8735
- 120 cm Long Steel Rod (2) ME-8741
- 45 cm Long Steel Rod ME-8736
- Multi Clamps (2) ME-9507
- Chaos/Driven Harmonic Accessory CI-6689A
- Mechanical Oscillator/Driver ME-8750
- Rotary Motion Sensor PS-2120
- Photogate Head ME-9498A

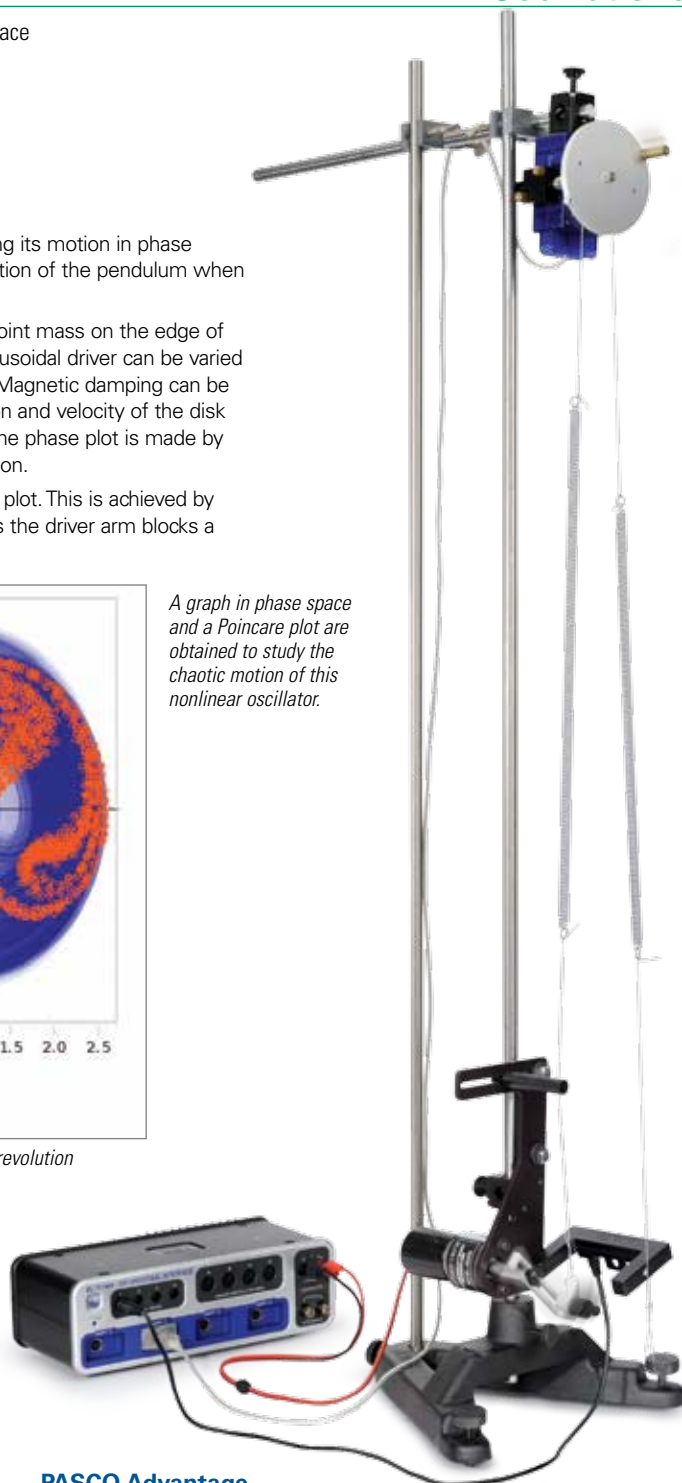

### PASCO Advantage

PASCO Capstone can graph the motion in phase space and superimpose the Poincare plot in real-time, showing students how the motion in phase space relates to actual motion of the oscillator.

### Order Information

Chaos .....EX-5523A

#### Required:

850 Universal Interface..... p. 12

PASCO Capstone Software ..... pp. 18-20

### Download This Experiment

The FREE experiment files include instructions in Microsoft Word™, PASCO Capstone workbook files with sample data, and graphics. Download these experiments at [www.pasco.com/CapstoneExperiments](http://www.pasco.com/CapstoneExperiments).

# Thermodynamics

## Specific Heat

EX-5524A

### Concepts:

- ▶ Thermal energy
- ▶ Equilibrium temperature
- ▶ Specific heat

Designed for use with any of the following:

- ▶ 850 Universal Interface
- ▶ 550 Universal Interface
- ▶ AirLink

Students learn that materials can be identified using specific heat as a measurable characteristic. A known mass of water is used and the unknown material is placed in the water. The initial temperature of the water and the unknown material are measured. The equilibrium temperature is found and from this the specific heat of the unknown material is derived.

By performing this experiment in two ways (water warming, water cooling) students explore how experiment design may alter results. Finally students explore source of error and magnitude of error.

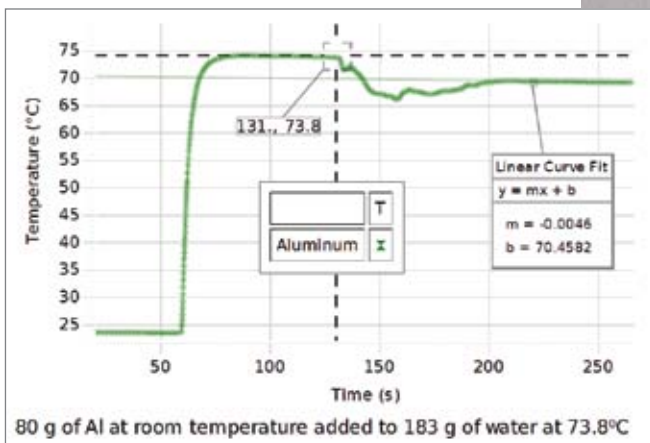

Room temperature Al is added to hot water. After 210 s, the system has come to equilibrium and is slowly cooling. A linear fit to the cooling curve allows extrapolation back to find the equilibrium temperature that would have occurred at 131 s when the Al was added if the system had come to equilibrium instantaneously. This allows measurement of the specific heat within approximately 10%.

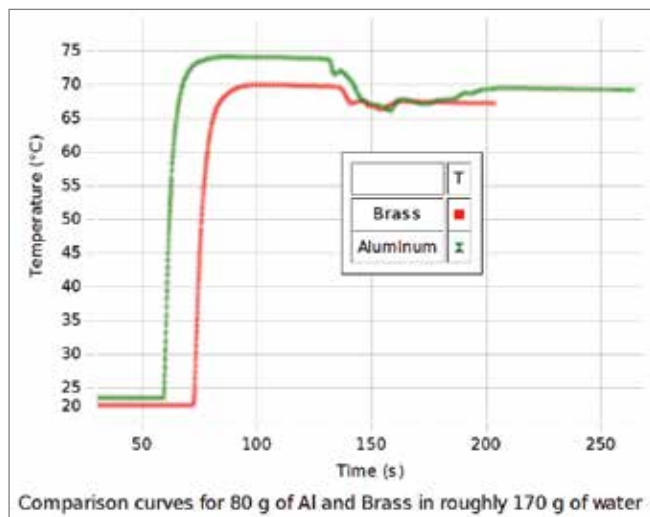

Comparison of similar system shows that Al causes about twice the drop in water temperature as does brass. The cooling slopes before and after support Newton's Law of Cooling.

### Experiment Includes

- Temperature Sensor PS-2125
- Calorimetry Cup with Lid SE-6849
- Specific Heat Set SE-8723
- Balance SE-8830
- Hot Plate SE-8830
- Graduated Cylinder, 50 mL
- 1000-mL Beaker
- Braided Physics String SE-8050

### Order Information

Specific Heat ..... EX-5524A

Required:  
 550 or 850 Universal Interface\* ..... pp. 12-14  
 PASCO Capstone Software ..... pp. 18-20

\* This experiment can be performed using the 550 or 850 Universal Interface or AirLink.

### Download This Experiment

The FREE experiment files include instructions in Microsoft Word™, PASCO Capstone™ workbook files with sample data, and graphics. Download these experiments at [www.pasco.com/CapstoneExperiments](http://www.pasco.com/CapstoneExperiments).

# Electrical Equivalent of Heat

Designed for use with the 850 Universal Interface

EX-5525

## Concept:

- ▶ Compare electrical energy input to changes in internal energy

The double wall of the aluminum Calorimeter Cup ensures good insulation. Energy is added to the system using the 10 Ω Heating Resistor, powered by the 850 Universal Interface. The voltage, current, power, and resulting increase in temperature are monitored and displayed continuously.

The amount of electrical energy used to heat the water (and the inner cup) is equal to the area under the power versus time curve. The amount of heat delivered to the water (and the inner cup) can be calculated using the increase in temperature and the mass of the water. The comparison of the electrical energy to the heat results in a value for the number of Joules in a calorie.

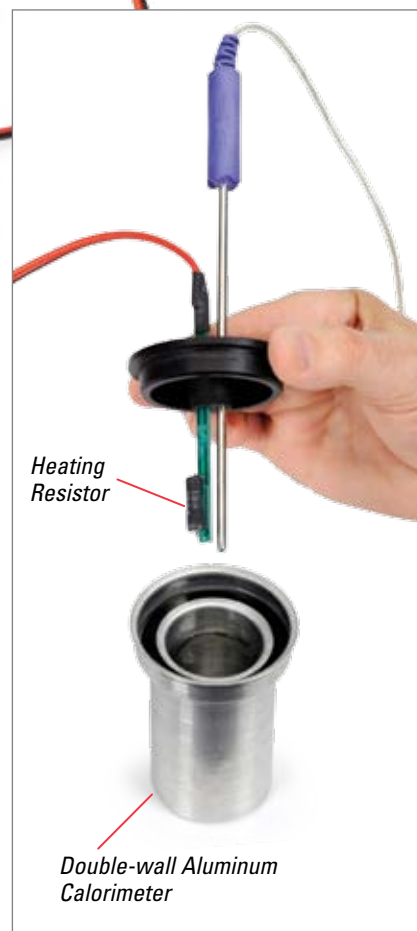
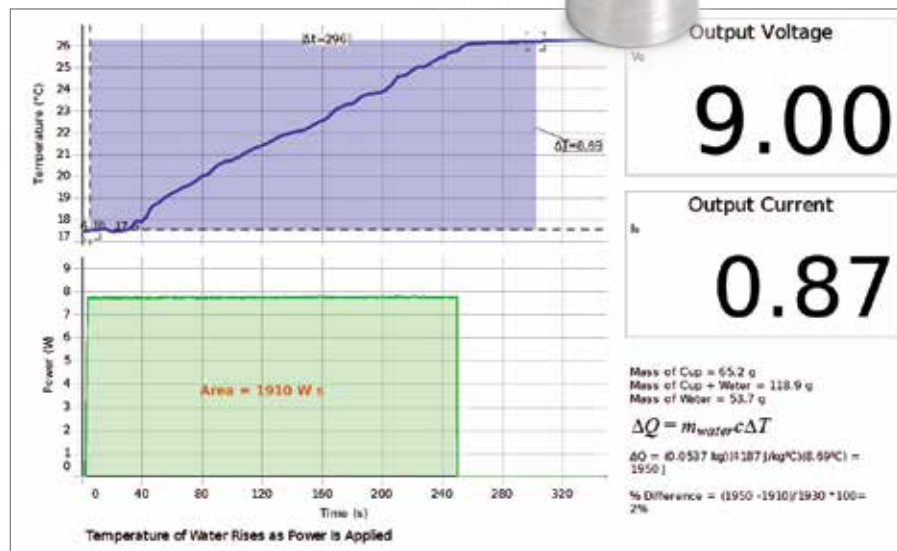

The bottom graph displays the power output from the generator and the top graph the increase in temperature. The amount of electrical energy used to heat to the water is determined by finding the area under the power versus time curve.

## Experiment Includes

- Energy Transfer-Calorimeter ET-8499
- Temperature Sensor PS-2125
- Mass Scale SE-8707

## Download This Experiment

The FREE experiment files include instructions in Microsoft Word™, PASCO Capstone workbook files with sample data, and graphics. Download these experiments at [www.pasco.com/CapstoneExperiments](http://www.pasco.com/CapstoneExperiments).

## Order Information

Electrical Equivalent of Heat .....	EX-5525
Required:	
850 Universal Interface .....	pp. 12-14
PASCO Capstone Software .....	pp. 18-20

# Thermodynamics

## Ideal Gas Law

EX-5527

Concepts:

- ▶ Ideal gas Law
- ▶ Boyle's Law
- ▶ Gay-Lussac's Law

The temperature, volume, and pressure of a gas are measured simultaneously to show that they change according to the Ideal Gas Law. Two special cases of the Ideal Gas Law are also examined: constant volume (Gay-Lussac's Law) and constant temperature (Boyle's Law). A syringe is used to vary the volume at constant temperature. A sphere of constant volume is immersed in different temperature water baths to show the change in pressure.

### PASCO Advantage

The Ideal Gas Syringe and Absolute Zero Sphere have a thermistor with small mass that responds quickly to temperature changes.

Designed for use with any of the following:

- ▶ 850 Universal Interface
- ▶ 550 Universal Interface
- ▶ AirLink



For the Ideal Gas Syringe (shown above) the Slope of the Volume vs.  $\frac{1}{P}$  graph equals  $nR$ .

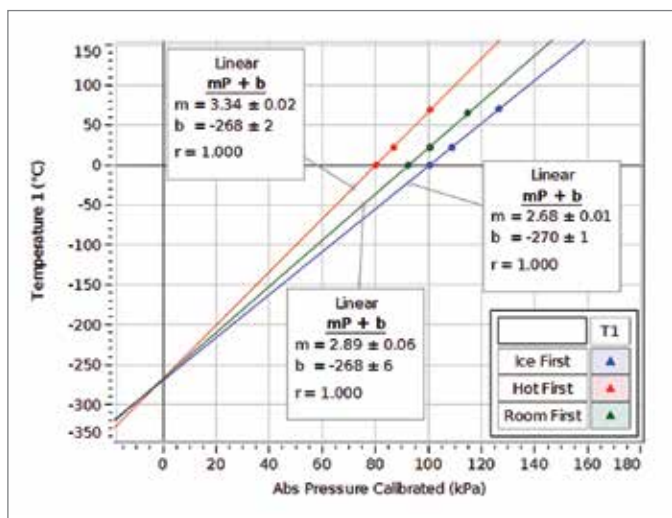

For the Absolute Zero Apparatus (shown at right) which has constant volume, the pressure versus temperature graphs have different slopes corresponding to different number of moles in the container.



### Download This Experiment

The FREE experiment files include instructions in Microsoft Word™, PASCO Capstone workbook files with sample data, and graphics. Download these experiments at [www.pasco.com/CapstoneExperiments](http://www.pasco.com/CapstoneExperiments).

### Experiment Includes

- Ideal Gas Law Syringe TD-8596A
- Pressure/Temperature Sensor PS-2146
- Absolute Zero Apparatus TD-8595
- Plastic Containers (2) 740-183

### Order Information

- Ideal Gas Law.....EX-5527
- Required:
- 550 or 850 Universal Interface\*..... pp. 12-14
- PASCO Capstone Software..... p. 18-20
- Calipers.....SE-8710 p. 182
- \* This experiment can be performed using the 550 or 850 Universal Interface or AirLink.

## Blackbody Radiation

EX-5529A

Designed for use with the 850 Universal Interface

### Concepts:

- ▶ Blackbody spectrum
- ▶ Peak wavelength versus temperature

The classic blackbody spectrum of light intensity versus wavelength is obtained for a light bulb and the shift in the peak wavelength is demonstrated for different bulb temperatures.

The spectrum of an incandescent light bulb is scanned by hand using a prism spectrophotometer, which measures relative light intensity as a function of angle. A Broad Spectrum Light Sensor is used with a prism, so the entire spectrum from approximately 400 nm to 2500 nm can be scanned without the overlapping orders caused by a grating. The wavelengths corresponding to the angles are calculated using the equations for a prism spectrophotometer. The relative light intensity can then be plotted as a function of wavelength as the spectrum is scanned, resulting in the characteristic blackbody curve. The intensity of the light bulb is reduced, reducing the temperature, and the scan is repeated to show how the curves nest with a shift in the peak wavelength.

The temperature of the bulb's filament can then be measured indirectly by determining the resistance of the bulb from the measured voltage and current. From the temperature, the theoretical peak wavelength can be calculated and compared to the measured peak wavelength.

*Note: Results are qualitative and suitable for introductory classes only.*

### PASCO Advantage

All the complex calculations for the angle-to-wavelength conversion are stored in the set-up file supplied for PASCO Capstone.

### Experiment Includes

- Prism Spectrophotometer Kit OS-8544
- Optics Bench (60 cm) OS-8541
- Spectrophotometer Accessory Kit OS-8537
- Aperture Bracket OS-8534A
- Broad Spectrum Light Sensor PS-2150
- Rotary Motion Sensor PS-2120A
- Voltage Sensor UI-5100
- Replacement Bulb (10 pk) SE-8509
- Banana Plug Cord-Black (5 pack) SE-9751

*The continuous blackbody spectrum is scanned using a prism spectrophotometer.*

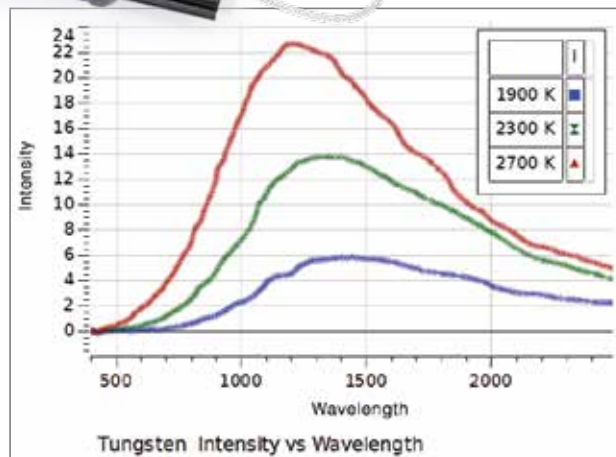
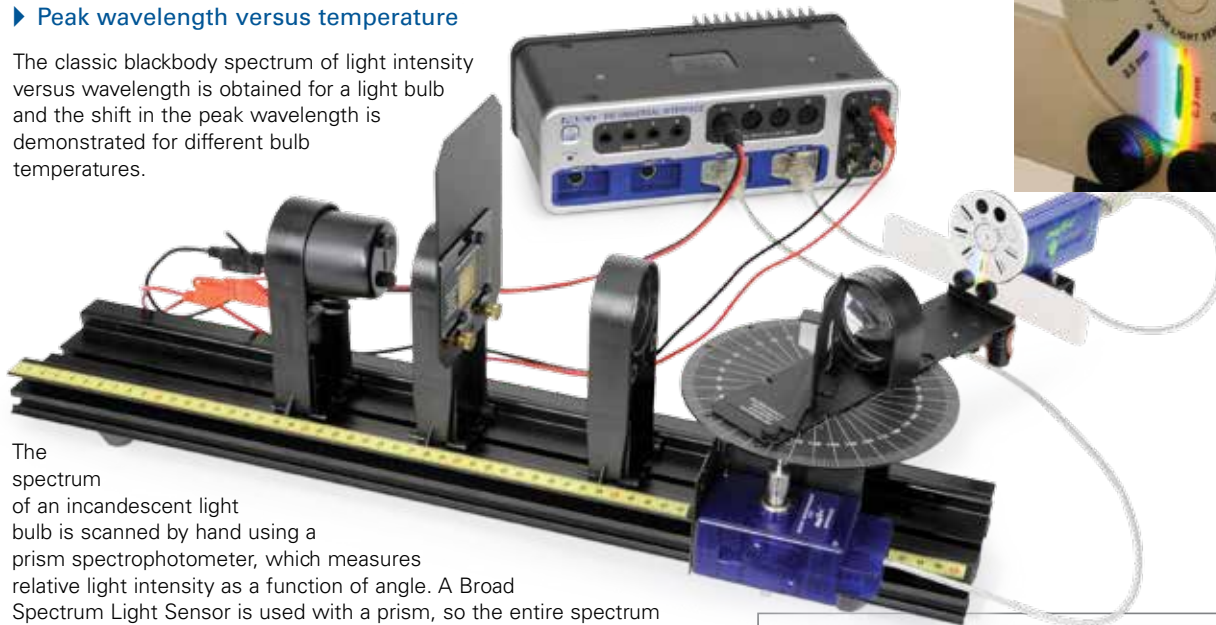
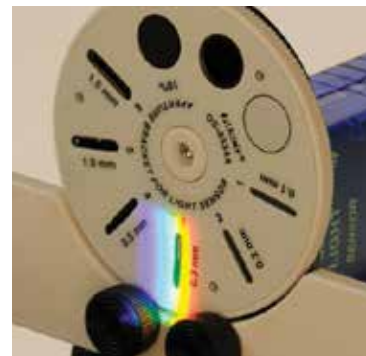

*Classic textbook diagram of the intensity versus wavelength blackbody curves can be produced with real data. In this graph, the peak wavelength in the blackbody curve shifts as the source temperature is decreased.*

### Download This Experiment

The FREE experiment files include instructions in Microsoft Word™, PASCO Capstone workbook files with sample data, and graphics. Download these experiments at [www.pasco.com/CapstoneExperiments](http://www.pasco.com/CapstoneExperiments).

### Order Information

Blackbody Radiation ..... EX-5529A

#### Required:

850 Universal Interface ..... p. 12

PASCO Capstone Software ..... p. 18-20

# Thermodynamics

## Heat Engine Cycle

EX-5530B

Designed for use with any of the following:

- ▶ 850 Universal Interface
- ▶ Any PASPORT interface with 3 ports

### Concepts:

- ▶ Heat engine efficiency
- ▶ Isothermal processes
- ▶ Isobaric processes
- ▶ Ideal gas law

A P-V diagram is generated as a heat engine is taken through a cycle. From this diagram, the heat added to the gas and the work done by the engine are measured to determine the efficiency. This actual efficiency is compared to the theoretical maximum efficiency.

The heat engine consists of air inside a cylinder that expands when an attached can is immersed in hot water. The expanding air pushes on a piston and does work by lifting a weight. The heat engine cycle is completed by immersing the can in cold water, which returns the air pressure and volume to the starting values.

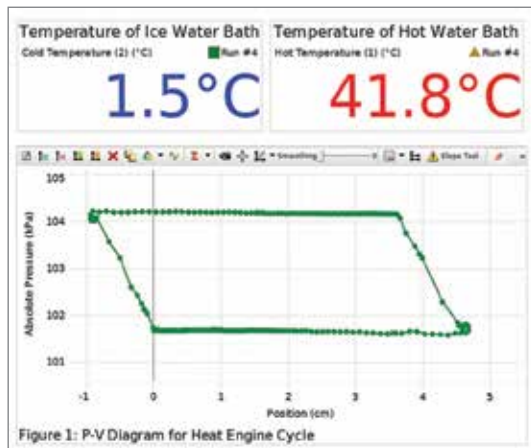

The PASCO Capstone™ graph shows an isobaric/isothermal heat engine cycle operating between a cold water bath at 1.5°C and a hot water bath at 41.8°C.

The actual efficiency is determined for a heat engine that lifts a weight as heat is added to the gas.

### PASCO Advantage

This operating heat engine shows how a difference in temperature can be used to do work. Each part of the cycle is easily identifiable, and the actual efficiency as well as the maximum possible efficiency can be easily determined.

### The cycle is performed as follows:

1. With the can in the cold bath, the 200 g mass is placed on the platform.
2. The can is moved from the cold bath to the hot bath.
3. The 200 g mass is removed from the platform.
4. The can is moved from the hot bath to the cold bath.

The change in pressure is measured with a Low Pressure Sensor. The change in piston height is measured by the attached string over the Rotary Motion Sensor pulley. The change in volume is calculated by multiplying the change in piston height by the piston cross-sectional area.

### Download This Experiment

The FREE experiment files include instructions in Microsoft Word™, PASCO Capstone workbook files with sample data, and graphics. Download these experiments at [www.pasco.com/CapstoneExperiments](http://www.pasco.com/CapstoneExperiments).

### Experiment Includes

- Heat Engine/Gas Law Apparatus TD-8572A
- Large Rod Stand ME-8735
- Slotted Mass (200 g) SE-8811
- Mass & Hanger Set ME-8979
- Plastic containers (2) ME-7559
- Thread
- 90 cm Long Steel Rod ME-8738
- Rotary Motion Sensor PS-2120A
- Quad Temperature Sensor PS-2143
- Dual Pressure Sensor PS-2181

### Order Information

Heat Engine Cycle.....EX-5530B

Required:

550 or 850 Universal Interface\* ..... pp. 12-14  
 PASCO Capstone Software..... pp. 18-20

\* This experiment can be performed using the 850 Universal Interface or any PASPORT interface with three ports.

## Ratio of Specific Heats

EX-5531A

Designed for use with any of the following:

- ▶ 850 Universal Interface
- ▶ 550 Universal Interface
- ▶ AirLink

### Concepts:

- ▶  $C_p/C_v$  for a gas
- ▶ Ruchhardt's method of measuring the ratio of specific heats
- ▶ Adiabatic process

In this experiment, the ratio of specific heat capacities for air is determined using Ruchhardt's Method of measuring the period of oscillation of the piston in a cylinder filled with air.

A cylinder is filled with air and a Pressure Sensor is attached. The piston is plucked by hand and allowed to oscillate. The oscillating pressure is recorded as a function of time and the period is determined. The ratio of specific heat capacities is calculated using the period of oscillation, according to Ruchhardt's method.

### PASCO Advantage

Since the oscillations are plotted, it is easy to accurately measure the period of oscillation.

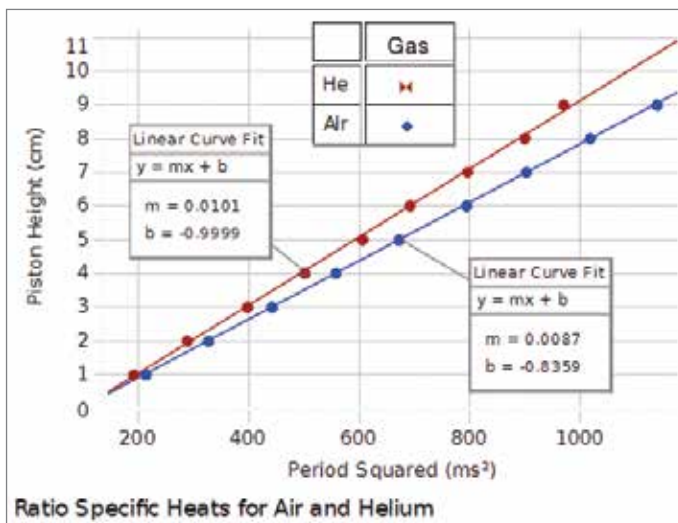

A plot of the position of piston versus the square of the period shows that the period increases as the gas volume increases. The slope of the line is related to the ratio of specific heats ( $C_p/C_v$ ) and is different for the two gases.

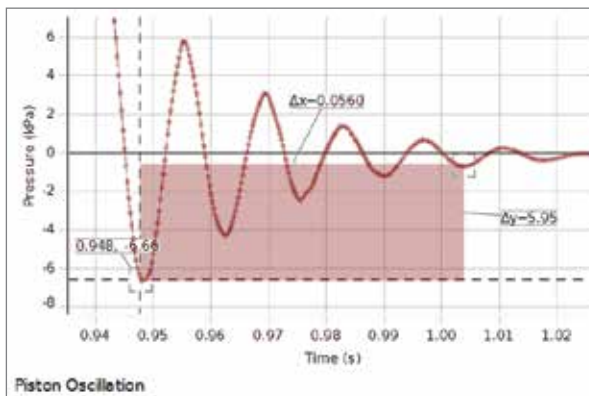

The pressure oscillates after the piston is plucked by hand.

### Experiment Includes

- Heat Engine/Gas Law Apparatus TD-8572A
- Large Rod Stand ME-8735
- 45 cm Long Steel Rod ME-8736
- Dual Pressure Sensor PS-2181

### Download This Experiment

The FREE experiment files include instructions in Microsoft Word™, PASCO Capstone workbook files with sample data, and graphics. Download these experiments at [www.pasco.com/CapstoneExperiments](http://www.pasco.com/CapstoneExperiments).

### Order Information

- Ratio of Specific Heats ..... EX-5531A  
 Required:  
 550 or 850 Universal Interface\* ..... pp. 12-14  
 PASCO Capstone Software ..... pp. 18-19  
 \* This experiment can be performed using the 550 or 850 Universal Interface or AirLink.

# Electromagnetism

## Electrostatic Charge

EX-5532

**Concepts:**

- ▶ Methods of charging
- ▶ Charge distribution
- ▶ Conservation of charge

Using classic equipment, a Faraday Ice Pail and Conductive Spheres, students learn to charge objects by direct contact and by induction. The charge is measured using a high impedance electrometer.

Students explore the distribution of charge on different shaped conductive shapes. A sphere with a hole in it is provided to show that no charge resides on the inner surface of the conductor when it is charged.



*Use the ball end to sample inside the hollow sphere.*



*New Digital Readout*



**Experiment Includes**

- Basic Electrometer ES-9078A
- Charge Producers and Proof Plane ES-9057C
- Faraday Ice Pail and Shield ES-9042A
- Conductive Spheres, 13 cm ES-9059C
- Conductive Shapes ES-9061
- Electrostatics Voltage Source ES-9077

**Order Information**

Electrostatic Charge.....EX-5532  
**Required:**  
 PASCO Capstone Software .....pp. 18-20  
 (No interface required.)

**Download This Experiment**

The FREE experiment files include instructions in Microsoft Word™, PASCO Capstone workbook files with sample data, and graphics. Download these experiments at [www.pasco.com/CapstoneExperiments](http://www.pasco.com/CapstoneExperiments).

## Coulomb's Law

EX-9930B

### Concepts:

- ▶ Verify the Inverse Square Law:  $F \sim 1/R^2$
- ▶ Verify the Force/Charge Relationship:  $F \sim q_1 q_2$
- ▶ Determine Coulomb's Constant:  $k = 9.0 \times 10^9 \text{ Nm}^2/\text{C}^2$

A conductive sphere is mounted on the end of an insulating, counterbalanced rod and suspended from a very thin torsion wire. An identical sphere is mounted on a calibrated linear track and can be positioned at various distances from the first sphere. When the conductive spheres are charged, the force between them is proportional to the twist of the torsion wire that is required to bring the balance back to its equilibrium position. Introductory physics students can determine the Inverse Square Law in a simple experiment, while advanced students can perform investigations into all the variables involved in electrostatic repulsion.

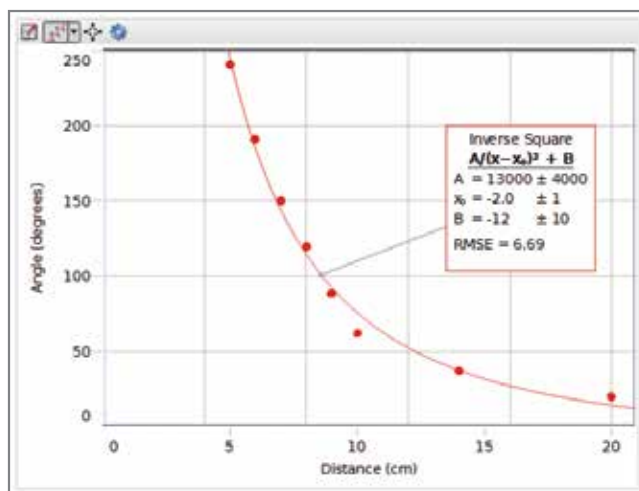

*Electrostatic force is directly proportional to the angle of twist and the angle of twist is proportional to the inverse square of the separation of the balls.*



*When an electrostatic force is applied, the torsion wire is twisted to return the balance to equilibrium. The twist of the wire is proportional to the electrostatic repulsion force.*

### Experiment Includes

- Coulomb's Law Apparatus ES-9070
- Kilovolt Power Supply SF-9586B
- Basic Electrometer ES-9078A
- Faraday Ice Pail ES-9042A
- Charge Producers and Proof Plane ES-9057C
- Coulomb's Law Experiment Manual

### Order Information

Coulomb's Law.....EX-9930B  
(No interface required.)

### To Download This Experiment

Search for EX-9930B at [www.pasco.com](http://www.pasco.com)

# Electromagnetism

## Charge of an Electron

EX-9929A

### Concepts:

- ▶ Accurately measure the charge of a single electron
- ▶ Recreate Robert Millikan's historical experiment

Small droplets of oil are introduced into a chamber where an electric field of known strength is present. Using the viewing scope and a stopwatch, the velocity of a falling oil droplet is measured and recorded. Next, the electric field in the chamber is increased, causing the oil droplet to move upward. This allows the measurement of the force on the droplet and, ultimately, the charge of the droplet. By measuring the charge of several different oil droplets, the smallest difference in charge between them can be equated to the charge of an electron.



### PASCO Advantage

PASCO's Charge of an Electron Experiment features a 30x, bright-field, erect-image microscope for clear viewing of the oil droplets. The droplet viewing chamber utilizes a special condenser to minimize droplet drift typically caused by droplet illumination and outside air currents. An ionization source allows the droplet charge to be changed.

### Experiment Includes

- Millikan Oil Drop Apparatus AP-8210
- Basic Digital Multimeter SE-9786A
- High Voltage Power Supply SF-9585A
- Large Rod Base ME-8735
- 45 cm Steel Rod (2) ME-8736
- Banana Plug Cord-Red (5 Pack) SE-9750
- Banana Plug Cord-Black (5 Pack) SE-9751
- Charge of an Electron Experiment Manual

#### Easy Cleaning

The condenser system easily disassembles for cleaning and inspection.

#### Condenser Housing

#### Minimum Electric Field Distortion

A 0.5 mm diameter droplet entry hole in the top capacitor plate has a negligible effect on the electric field.

#### Ionization Source

The thorium-232 alpha source can be activated by the switch on the side of the chamber. The source allows the charge on the oil droplets to be changed.

#### Droplet Hole Cover

Prevents additional droplets from entering the chamber once the experiment has started.

#### Polished Surfaces

Polished surfaces on the plate spacer minimize absorption of light (and heat) through the chamber walls.

#### Electrical Connection

Electrical connection to the top plate

Condenser Assembly

### To Download This Experiment

Search for EX-9929A at [www.pasco.com](http://www.pasco.com)

### Order Information

Charge of an Electron .....EX-9929A  
(No interface required.)

## Capacitance

EX-5533

Designed for use with any of the following:

- ▶ 850 Universal Interface
- ▶ 550 Universal Interface

### Concepts:

- ▶ Capacitance
- ▶ Parallel plate capacitor
- ▶ Factors affecting capacitance

This lab explores the effect of varying the plate distance and insulating dielectric materials in a variable flat plate capacitor.

The Electrometer used in this experiment makes it possible to measure the voltage across the capacitor without discharging the capacitor, since it has an internal resistance of  $10^{14}$  ohms.

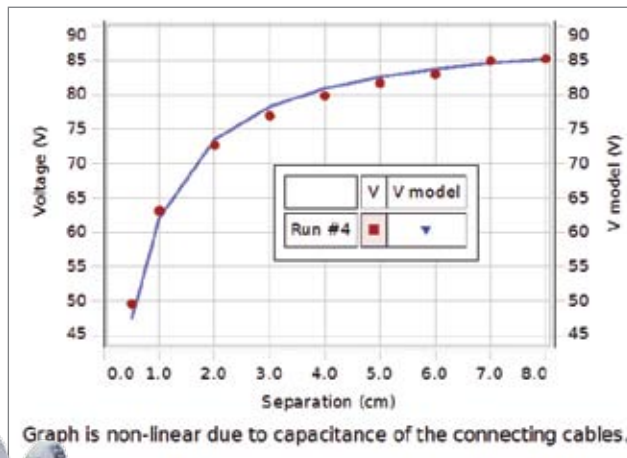

Graph is non-linear due to capacitance of the connecting cables.

Manipulation of the computer model allows measurement of the capacitance of the connecting cables and the charge on the system.

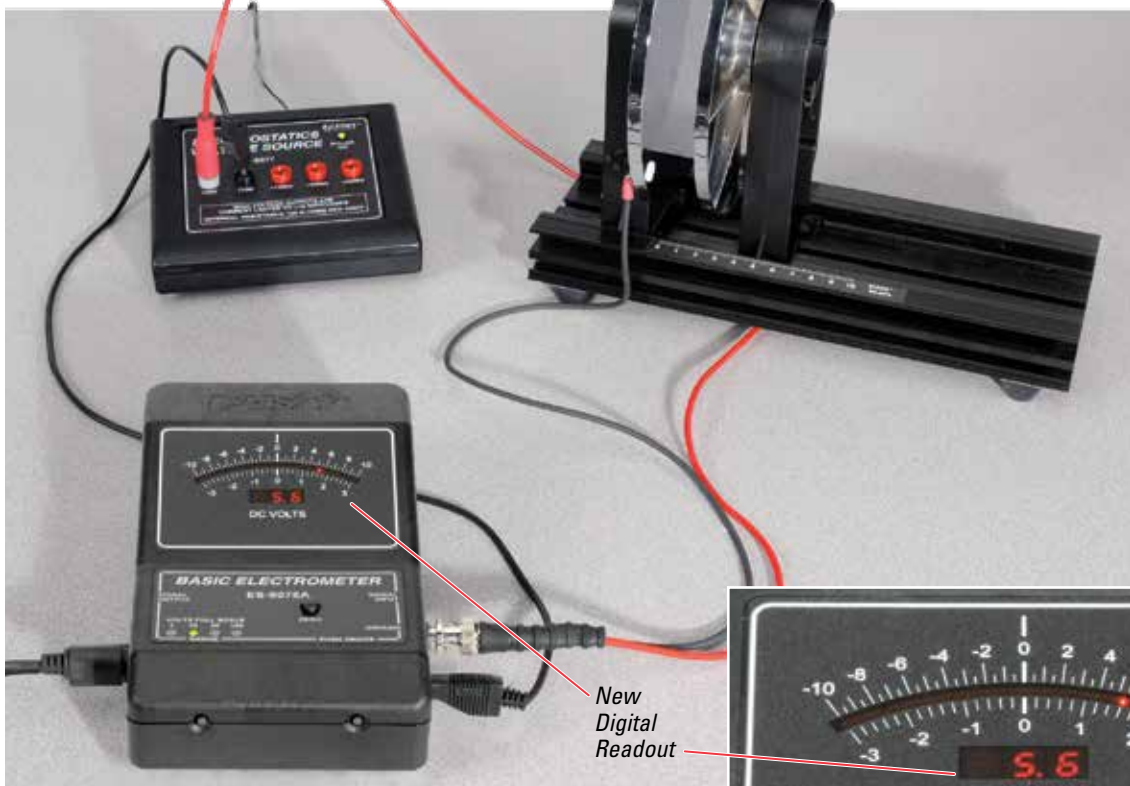

New Digital Readout



### Experiment Includes

- Basic Electrometer ES-9078A
- Basic Variable Capacitor ES-9079
- Electrostatics Voltage Source ES-9077

### Order Information

- Capacitance.....EX-5533
- Required:
- 550 or 850 Universal Interface..... pp. 12-14
- PASCO Capstone Software..... pp. 18-20

### Download This Experiment

The FREE experiment files include instructions in Microsoft Word™, PASCO Capstone workbook files with sample data, and graphics. Download these experiments at [www.pasco.com/CapstoneExperiments](http://www.pasco.com/CapstoneExperiments).

# Electromagnetism

**Resistivity** Designed for use with the 850 Universal Interface  
EX-5534

**Concepts:**

- ▶ Relate resistance to wire length
- ▶ Determine resistivity of different materials

Discover the relationship between the resistance of a wire and its length, diameter, and the resistivity of the metal.

The current is measured directly by the 850 Universal Interface, and the voltage drop over the selected section of wire is measured by the Voltage Sensor. This allows easy calculation of the resistance of the length of wire. The resistance is plotted versus the length of the wire, and the slope of the resulting straight line is used to determine the resistivity.

Using wires of the same diameter made of different materials allows examination of the effect of resistivity. Using brass wires with various diameters allows examination of the effect diameter has on resistance.

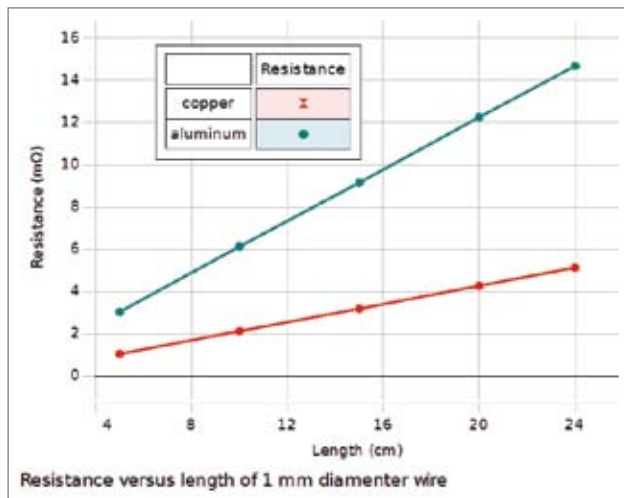

Since both wires have the same diameter, the resistivity is directly proportional to the slope. The graph shows that the resistivity of copper is about one-third that of aluminum.



The Resistance Apparatus has a slide wire probe to easily change the measured length of the wire, and it utilizes a four wire hook-up to accurately measure the voltage drop. It comes with four different brass wire diameters and four other wire materials.

**PASCO Advantage**

The Resistance Apparatus has a slide-wire probe to easily change the measured length of the wire. It utilizes a four-wire hook-up to accurately measure the voltage drop.

The 850 Universal Interface Power Amplifier makes it possible to scan the voltages, allowing more time to examine wires made of different metals and with different diameters.

**Experiment Includes**

- Resistance Apparatus EM-8812
- Voltage Sensor UI-5100
- Patch cords (set of 5) SE-9750

**Order Information**

Resistivity .....EX-5534

**Required:**

- 850 Universal Interface ..... p. 12
- PASCO Capstone Software ..... pp. 18-20
- Micrometer ..... p. 182

**Download This Experiment**

The FREE experiment files include instructions in Microsoft Word™, PASCO Capstone workbook files with sample data, and graphics. Download these experiments at [www.pasco.com/CapstoneExperiments](http://www.pasco.com/CapstoneExperiments).

## Ohm's Law

EX-5535

Designed for use with any of the following:

- ▶ 850 Universal Interface
- ▶ 550 Universal Interface

### Concepts:

- ▶ Relationship between voltage and current

### Method

In this experiment, students simultaneously measure both current and voltage for a simple DC circuit. The relationship between current and voltage is explored for different resistors in parallel. Voltage is graphed versus current to verify Ohm's Law and recognize the physical meaning of slope.

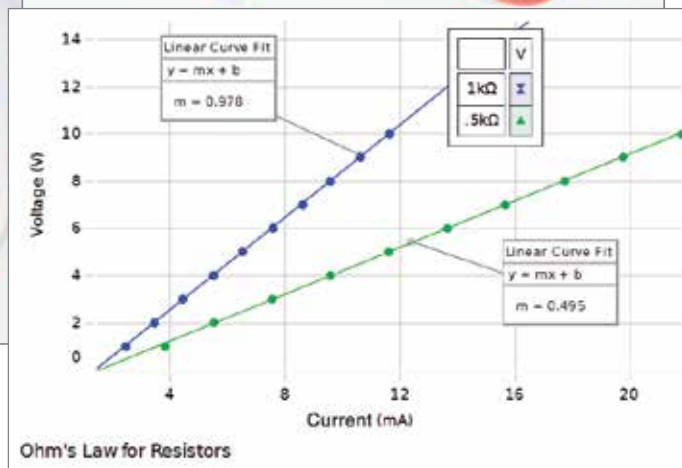

The relationship between voltage and current varies for different circuit resistance.

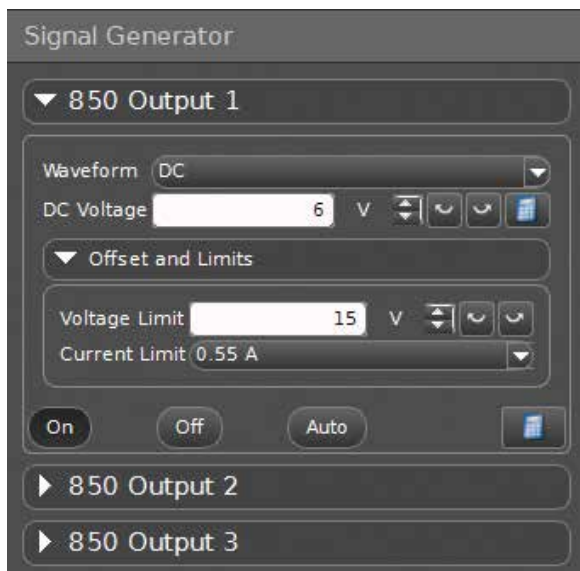

Students control output from the 850 signal generators directly from the user interface in PASCO Capstone.

### Experiment Includes

- Resistive/Capacitive/Inductive Network UI-5210
- Short Patch Cords (set of 8) SE-7123

### Download This Experiment

The FREE experiment files include instructions in Microsoft Word™, PASCO Capstone workbook files with sample data, and graphics. Download these experiments at [www.pasco.com/CapstoneExperiments](http://www.pasco.com/CapstoneExperiments).

### Order Information

- Ohm's Law ..... EX-5535
- Required:
- 550 or 850 Universal Interface ..... pp. 12-14
- PASCO Capstone Software ..... pp. 18-20

# Electromagnetism

## RC Circuit

EX-5536

Designed for use with any of the following:

- ▶ 850 Universal Interface
- ▶ 550 Universal Interface

### Concepts:

- ▶ Charging and discharging a capacitor
- ▶ Exponential growth and decay
- ▶ Time constants

Students collect data to understand the relationship between charging and discharging rates and the capacitance and resistance in a simple circuit. The time constant is derived and exponential growth and decay are explored.

### PASCO Advantage

The RC Circuit experiment is extremely simple and transparent to set up. It is very easy to measure the time to half charge. It is also easy to verify that the curve is exponential using the curve-fitting capability of PASCO Capstone Software.

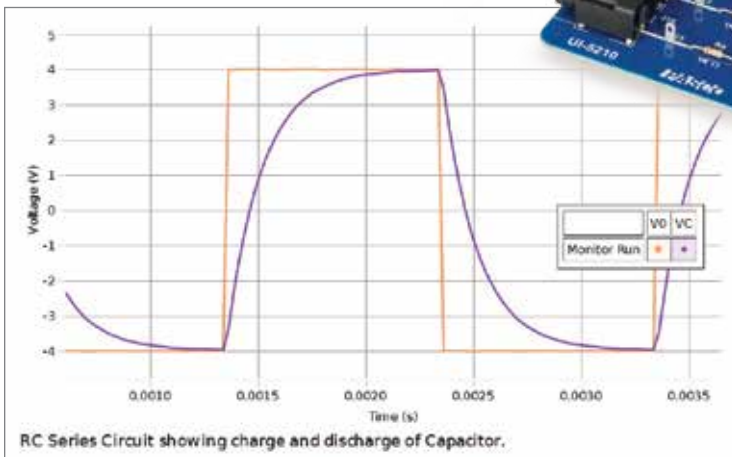
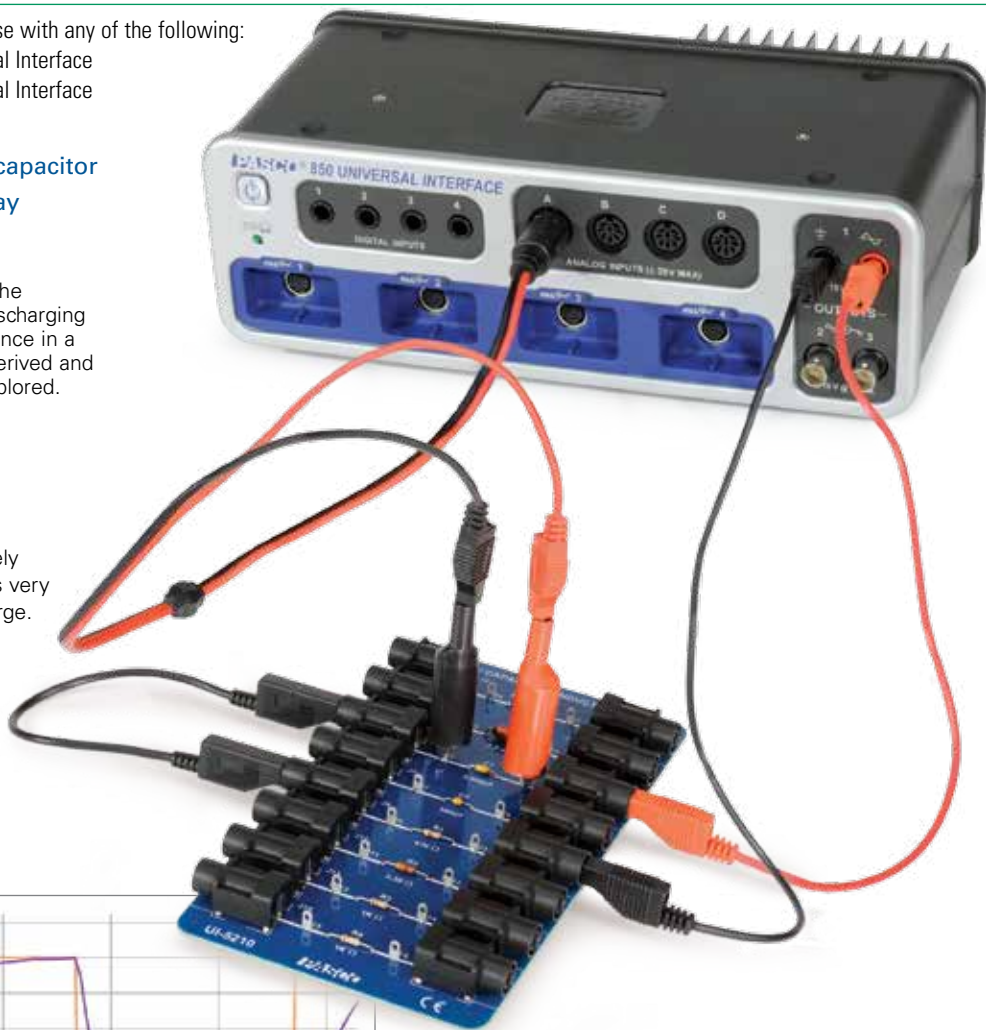

The actual capacitance is determined from the charge/discharge curve.

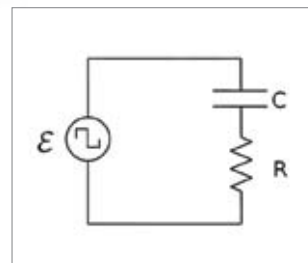

The 850 Universal Interface provides a very clean square wave to the series RC circuit.

### Experiment Includes

- Resistive/Capacitive/Inductive Network      UI-5210
- Voltage Sensor      UI-5100
- Short Patch Cords (set of 8)      SE-7123

### Download This Experiment

The FREE experiment files include instructions in Microsoft Word™, PASCO Capstone workbook files with sample data, and graphics. Download these experiments at [www.pasco.com/CapstoneExperiments](http://www.pasco.com/CapstoneExperiments).

### Order Information

RC Circuit.....EX-5536

#### Required:

550 or 850 Universal Interface..... pp. 12-14  
 PASCO Capstone Software..... p. 18-20

## LRC Circuit

Designed for use with the 850 Universal Interface

EX-5537

### Concepts:

- ▶ LC oscillations
- ▶ Inductive, capacitive, and resistive AC circuits
- ▶ LRC resonant frequency

The response of a series LRC circuit is examined at driving frequencies above, below, and at the resonant frequency. A sinusoidal voltage is applied individually to a resistor, a capacitor, and an inductor. The amplitude of the current and the phase difference between the applied voltage and the current are measured in each of the three circuits to see the effect each component has on the current. Finally, a sinusoidal voltage is applied to an inductor, resistor, and capacitor in series.

The amplitude of the current and the phase difference between the applied voltage and the current are measured and compared to theory.

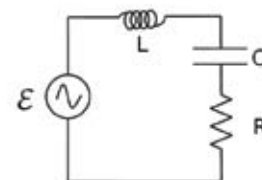

The 850 Interface supplies AC voltage to an LRC series circuit.

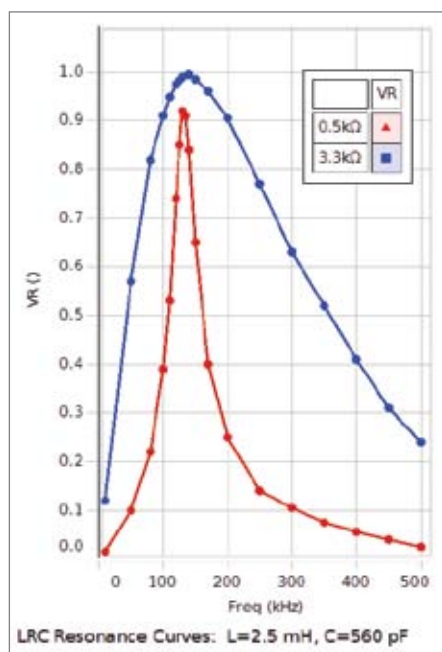

The effect of circuit resistance on peak width is clear and leads to an understanding of how to design a filter for a circuit.

### Experiment Includes

- Resistive/Capacitive/Inductive Network UI-5210
- Voltage Sensors (3) UI-5100
- Short Patch Cords (set of 8) SE-7123
- BNC to Banana Output Cable UI-5119

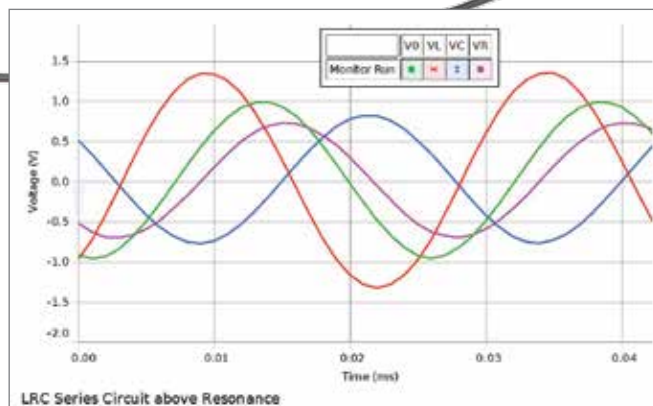

LRC Series Circuit above Resonance

The oscilloscope display in PASCO Capstone is used to simultaneously display the voltages across the inductor, capacitor, and resistor, as well as the source voltage.

### Download This Experiment

The FREE experiment files include instructions in Microsoft Word™, PASCO Capstone workbook files with sample data, and graphics. Download these experiments at [www.pasco.com/CapstoneExperiments](http://www.pasco.com/CapstoneExperiments).

### Order Information

LRC Circuit.....	EX-5537
<b>Required:</b>	
850 Universal Interface.....	p. 12
PASCO Capstone Software.....	p. 18-20

# Electromagnetism

## Kirchhoff's Circuit Law

EX-5538

Designed for use with any of the following:

- ▶ 850 Universal Interface
- ▶ 550 Universal Interface

### Concepts:

- ▶ Summation of the voltages around a closed loop are zero at any instant
- ▶ Summation of the currents at any junction are zero

Kirchhoff's Laws form the basis of all circuit analysis. The high speed for AC applications and high sensitivity (0.1 mA) for DC applications make the 850 Interface an ideal tool for investigating AC and DC circuits.

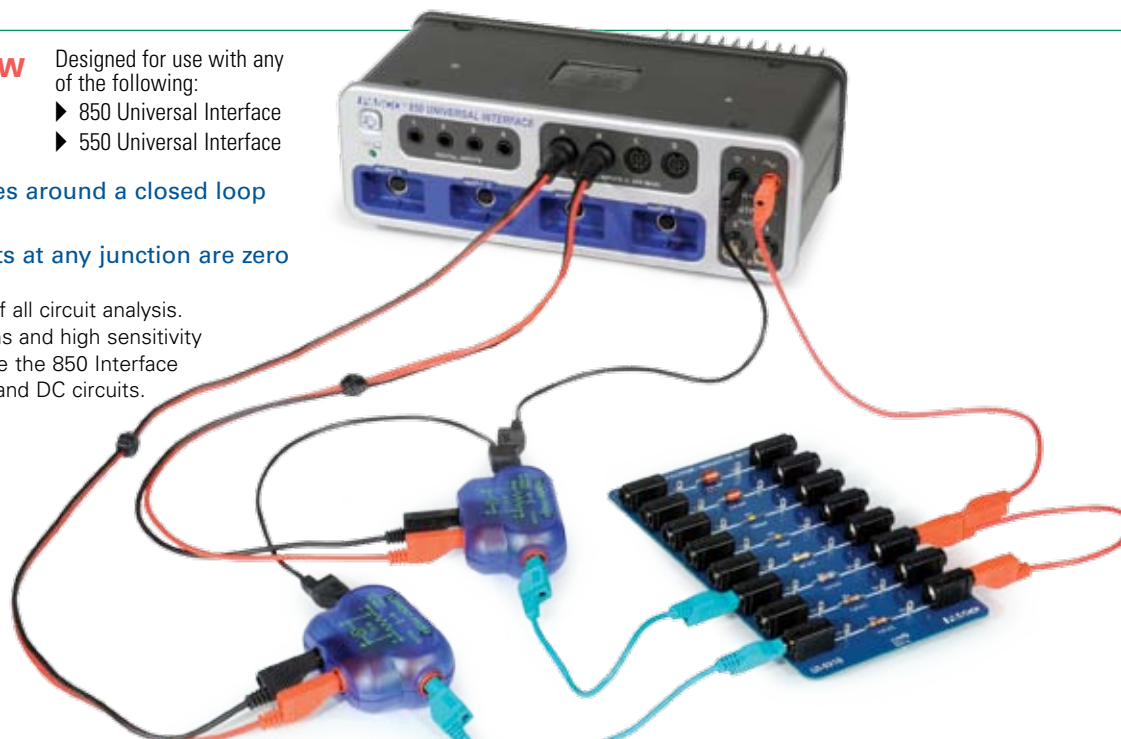

Students control output from the 850 signal generators directly from the user interface in PASCO Capstone.

Signal Generator

▼ 850 Output 1

Waveform DC

DC Voltage  V

▼ Offset and Limits

Voltage Limit  V

Current Limit 0.55 A

On Off Auto

▶ 850 Output 2

▶ 850 Output 3

Total Current

19.7mA

---

Current 1

15.2mA

---

Current 2

4.5mA

Measurement of voltages and currents in series-parallel DC circuits demonstrates the validity of Kirchhoff's Laws. The use of multiple current probes avoids student confusion that can arise when rearranging the circuit to measure currents at different points.

Students compare the current flow through each resistor to the total current output from the 850.

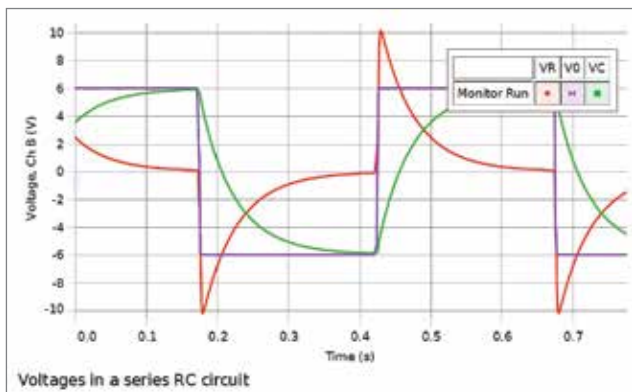

The high speed of the 850 Universal Interface, in scope mode, allows the examination of time varying voltages in an RC circuit to verify that Kirchhoff's loop theorem holds even when voltage is not constant.

### Experiment Includes

- Resistive/Capacitive/Inductive Network UI-5210
- Voltage Sensors (3) UI-5100
- Current Probe (2) PS-2184
- Short Patch Cords (set of 8) SE-7123

### Download This Experiment

The FREE experiment files include instructions in Microsoft Word™, PASCO Capstone workbook files with sample data, and graphics. Download these experiments at [www.pasco.com/CapstoneExperiments](http://www.pasco.com/CapstoneExperiments).

### Order Information

Kirchhoff's Circuit Law .....	EX-5538
<b>Required:</b>	
550 or 850 Universal Interface .....	pp. 12-14
PASCO Capstone Software .....	pp. 18-20

## Earth's Magnetic Field

EX-5539A

### Concepts:

- ▶ Magnitude of the earth's magnetic field
- ▶ Direction of earth's magnetic field
- ▶ Dip angle

The magnitude and direction of the Earth's magnetic field are measured using a Magnetic Field Sensor mounted on a Rotary Motion Sensor. The Magnetic Field Sensor is rotated through 360 degrees by rotating the Rotary Motion Sensor pulley by hand. The Magnetic Field Sensor is zeroed using the Zero Gauss Chamber, the walls of which are made of a highly permeable material that redirects the magnetic field around the chamber.

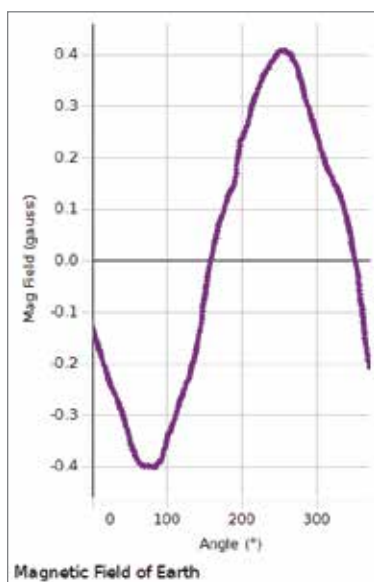

The Earth's magnetic field is measured as the Magnetic Field Sensor is rotated 360 degrees in the Earth's field.

### PASCO Advantage

The sensitive Magnetic Field Sensor combined with the Rotary Motion Sensor enables the measurement of the magnetic field strength as a function of angle from North. It is essentially a computerized compass that can measure both the direction and the magnitude of the field.

Designed for use with any of the following:

- ▶ 850 Universal Interface
- ▶ 550 Universal Interface
- ▶ Any PASPORT interface with 2 ports



The Magnetic Field Sensor is mounted on a Rotary Motion Sensor to measure the magnitude and direction of the Earth's magnetic field.

### Experiment Includes

- |  |          |
|--|----------|
| • 2-Axis Magnetic Field Sensor         | PS-2162  |
| • Zero Gauss Chamber                   | EM-8652  |
| • Rotary Motion Sensor                 | PS-2120A |
| • Dip Needle                           | SF-8619  |
| • Aluminum Table Clamp                 | ME-8995  |
| • 25 cm Stainless Steel Rod (threaded) | ME-8988  |
| • Adjustable Angle Clamp               | ME-8744  |
| • Angle Indicator                      | ME-9495A |

### Order Information

Earth's Magnetic Field ..... EX-5539A

Required:

550 or 850 Universal Interface\* ..... pp. 12-14  
 PASCO Capstone Software ..... pp. 18-20

\* This experiment can be performed using the 850 or 550 Universal Interface or any PASPORT interface with two ports.

### Download This Experiment

The FREE experiment files include instructions in Microsoft Word™, PASCO Capstone workbook files with sample data, and graphics. Download these experiments at [www.pasco.com/CapstoneExperiments](http://www.pasco.com/CapstoneExperiments).

# Electromagnetism

## Magnetic Forces on Wires

EX-9933

### Concepts:

- ▶ Relationship between:
  - force and current, force and length of wire,
  - force and magnetic field strength, force and angle

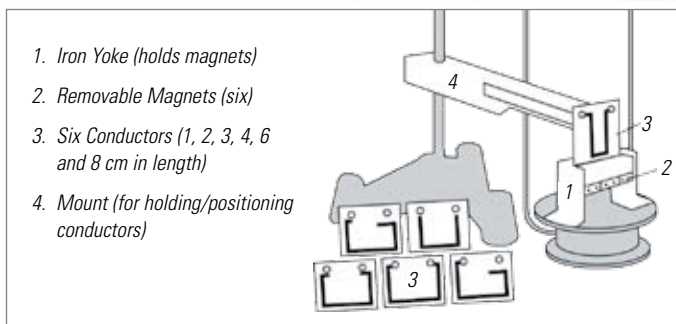
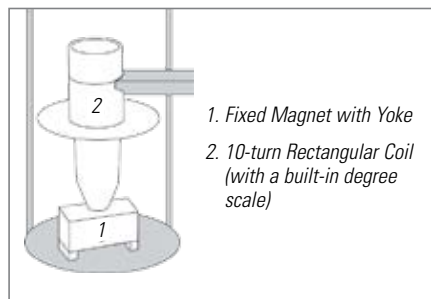

Magnets are mounted on an iron yoke and placed on a balance (resolution of at least 0.01 g). One of the conducting paths is suspended between the magnets. The balance is used to measure the mass of the magnets and yoke prior to any current passing through the conducting path. Current is then passed through the conducting path, producing a force. The change in reading on the balance can be converted to find the magnetic force between the conductor and magnetic field.

Conductors of different lengths are included to measure the effect of length on magnetic force. Magnetic field can be varied by changing the number of magnets in the yoke. The power source is used to change the current supplied to the conductor. The Current Balance Accessory includes all the components needed to test the effect of angle on magnetic force.

### PASCO Advantage

PASCO's Magnetic Force in Wires Experiment allows students to study the key variables (conductor length, current, magnetic field strength, and angle) that affect magnetic force.

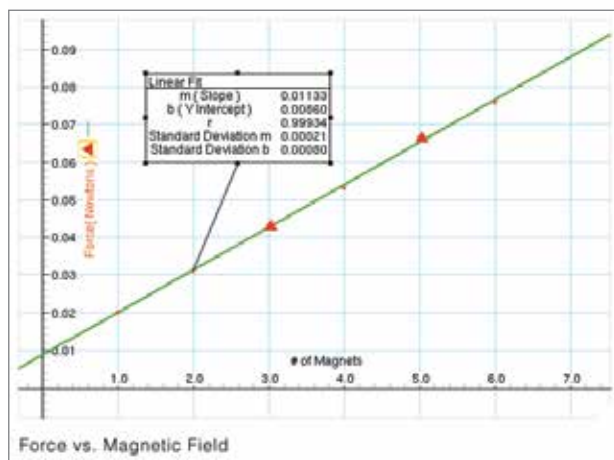

Graph illustrates the direct relationship between magnetic field and magnetic force.

### Experiment Includes

- Basic Current Balance SF-8607
- Current Balance Accessory SF-8608
- Ohaus Cent-o-Gram Balance SE-8725
- Low Voltage AC/DC Power Supply SF-9584B
- Large Base and Support Rod ME-9355
- Banana Plug Cord-Red (5 pack) SE-9750
- Banana Plug Cord-Black (5 pack) SE-9751
- Magnetic Forces on Wires Experiment Manual

### To Download This Experiment

Search for EX-9933 at [www.pasco.com](http://www.pasco.com)

### Order Information

Magnetic Forces on Wires .....EX-9933

## Magnetic Fields of Coils

EX-5540A

Designed for use with the  
850 Universal Interface

### Concepts:

- ▶ Magnetic fields of:  
single coil  
Helmholtz coils  
inside a solenoid

*This plot shows the magnetic field strength along the axis of Helmholtz coils for three different coil separations. The green data is for coils with the proper separation (the coil radius), the red data is for the coils too close together, and the blue data is for the coils too far apart.*

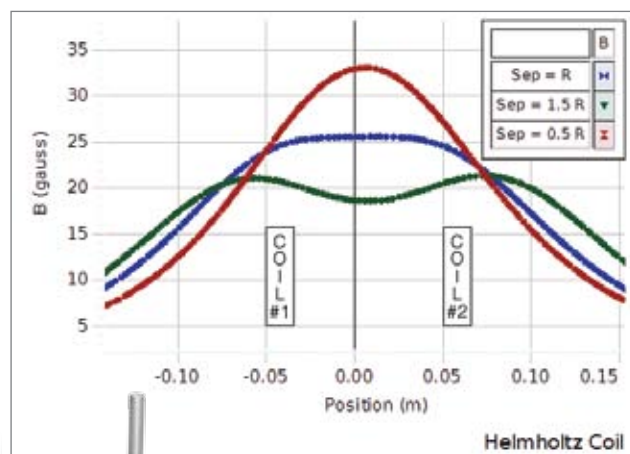

*The green curve is the measured magnetic field versus distance along the perpendicular axis of a single coil. The red theoretical curve is plotted from an equation.*

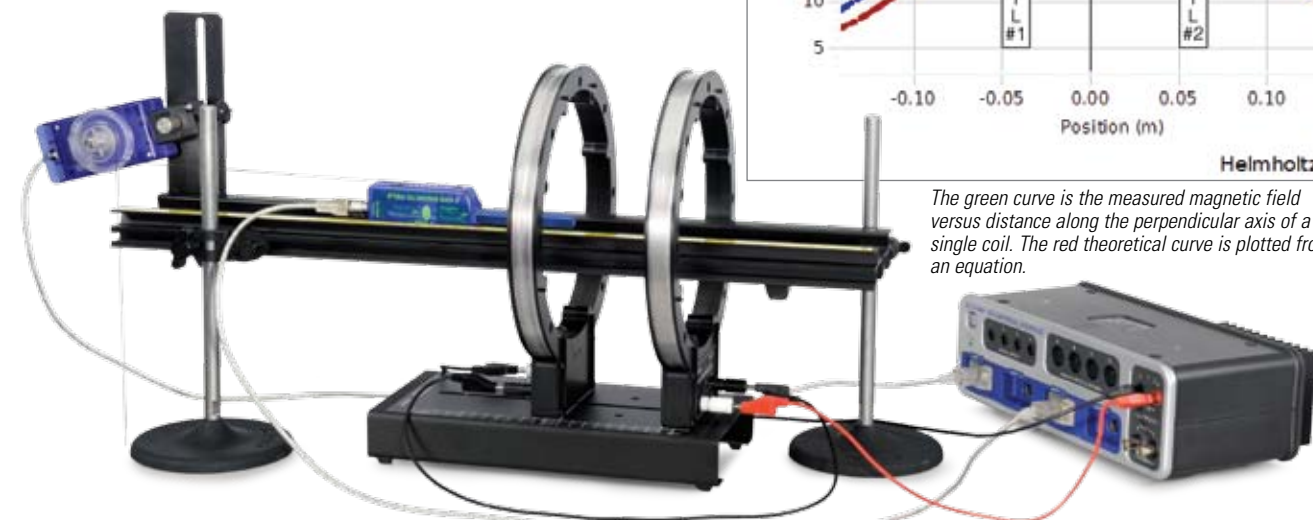

The dependence of the magnetic field strength of current-carrying coils on the distance from the coil along the perpendicular axis is determined and compared to the theoretical curve. In addition, the effect of varying the coil separation on the shape of the magnetic field between the Helmholtz coils is examined.

The magnetic fields of various coils are plotted versus position as the Magnetic Field Sensor is passed through the coils, guided by a track. The position is recorded by a string attached to the Magnetic Field Sensor that passes over the Rotary Motion Sensor pulley to a hanging mass.

It is particularly interesting to compare the field from Helmholtz coils at the proper separation of the coil radius to the field from coils separated at less than or more than the coil radius.

The magnetic field inside a solenoid can be examined in both the radial and axial directions.

*The magnetic field inside a solenoid is measured in the radial and axial directions.*

*The magnetic field of Helmholtz coils is measured as a function of distance along the perpendicular axis.*



### PASCO Advantage

Using the PASCO Capstone™ curve fit, the theoretical equation for the magnetic field can be plotted on the same graph.

### Experiment Includes

- |                                      |          |
|--------------------------------------|----------|
| • Helmholtz Coil Base                | EM-6715  |
| • Field Coil (2) (500 turn)          | EM-6723  |
| • Primary and Secondary Coils        | SE-8653  |
| • Patch Cords-red (set of 5)         | SE-9750  |
| • Patch Cords-black (set of 5)       | SE-9751  |
| • 60 cm Optics Bench                 | OS-8541  |
| • Dynamics Track Mount               | CI-6692  |
| • 20 g hooked mass (Hooked Mass Set) | SE-8759  |
| • Round Base with Rod (2 of each)    | ME-8270  |
| • Optics Bench Rod Clamps (set of 2) | OS-8479  |
| • 2-Axis Magnetic Field Sensor       | PS-2162  |
| • Rotary Motion Sensor               | PS-2120A |

### Order Information

Magnetic Fields of Coils .....EX-5540A

Required:

850 Universal Interface..... p. 12

PASCO Capstone Software ..... pp. 18-20

### Download This Experiment

The FREE experiment files include instructions in Microsoft Word™, PASCO Capstone workbook files with sample data, and graphics. Download these experiments at [www.pasco.com/CapstoneExperiments](http://www.pasco.com/CapstoneExperiments).

# Electromagnetism

## Faraday's Law of Induction

EX-5541A

Designed for use with any of the following:

- ▶ 850 Universal Interface
- ▶ 550 Universal Interface

### Concepts:

- ▶ Magnetic flux
- ▶ Faraday's Law of Induction
- ▶ Lenz's Law
- ▶ Conservation of energy
- ▶ Electrical power

A voltage is induced in a coil swinging through a magnetic field. Faraday's Law and Lenz's Law are examined and the energy dissipated in a load resistor is compared to the loss of energy of the coil pendulum.

A rigid pendulum with a coil at its end swings through a horseshoe magnet. A resistive load is connected across the coil and the induced voltage is recorded using a Voltage Sensor. The angle is measured with a Rotary Motion Sensor, which also acts as a pivot for the pendulum. The induced voltage is plotted versus time and angle. The power dissipated in the resistor is calculated from the voltage and the energy converted to thermal energy is determined by finding the area under the power versus time curve. This energy is compared to the loss of energy determined from the amplitude and speed of the pendulum.

Faraday's Law is used to estimate the magnetic field of the magnet from the maximum induced voltage. Also, the direction of the induced voltage as the coil enters and leaves the magnetic field is examined and analyzed using Lenz's Law.

*A voltage is induced in a coil swinging through a magnetic field.*

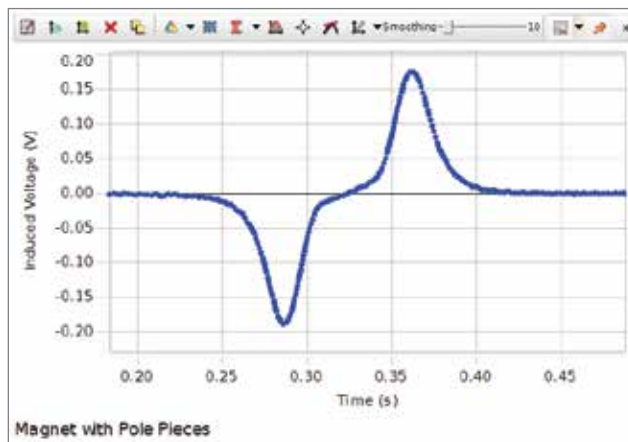

*Plot of induced voltage as coil swings through the magnet*



### PASCO Advantage

PASCO Capstone™ calculates energy and power using the voltage and angle data. The induced voltage and the calculations are plotted in real-time as the coil swings through the magnet.

### Experiment Includes

- Induction Wand EM-8099
- Variable Gap Lab Magnet EM-8641
- Large Rod Base ME-8735
- 45 cm Steel Rod (2) ME-8736
- Multi Clamp ME-9507
- Voltage Sensor UI-5100
- 2-Axis Magnetic Field Sensor PS-2162
- Rotary Motion Sensor PS-2120A

### Download This Experiment

The FREE experiment files include instructions in Microsoft Word™, PASCO Capstone workbook files with sample data, and graphics. Download these experiments at [www.pasco.com/CapstoneExperiments](http://www.pasco.com/CapstoneExperiments).

### Order Information

Faraday's Law of Induction ..... EX-5541A

*Required:*  
 550 or 850 Universal Interface ..... pp. 12-14  
 PASCO Capstone Software ..... pp. 18-20

## Vibrating String

EX-5542

Designed for use with the 850 Universal Interface

### Concepts:

- ▶ Investigate standing waves
- ▶ Pull string to adjust number of segments
- ▶ Vary frequency of vibration

Study standing waves in a string by varying the driver frequency and keeping the number of segments constant. The String Vibrator is powered by the 850 Universal Interface. Students vary both the frequency and amplitude.

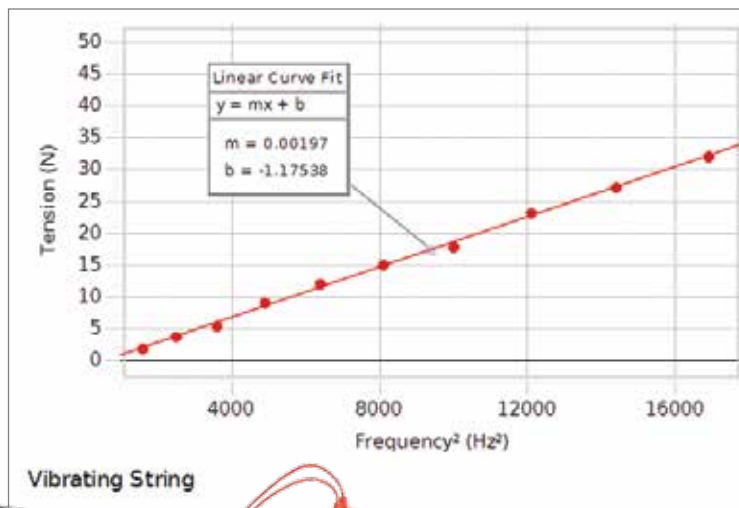

Vibrating String

*A graph of force vs. the square of the frequency shows a linear relationship. The slope of this line is related to the length and density of the string.*



### PASCO Advantage

The unusual approach in this version of the experiment is that the students actually provide the tension in the string by pulling directly on the force sensor. This is particularly instructive because the students get a feel for how the tension must change to vary the number of segments. Rather than hanging more weight over a pulley, the students must pull harder to achieve a smaller number of segments. This helps them remember the relationship between tension and wavelength.

The 850 Universal Interface controls the frequency and amplitude of the sine waves applied to the String Vibrator. As the frequency is gradually increased (in 10 Hz increments), the student pulls on the Force Sensor to adjust the tension for resonance with the string vibrating in two segments.

*The string tension is measured directly with a Force Sensor, enabling students to feel the force required to obtain a certain number of segments.*

### Download This Experiment

The FREE experiment files include instructions in Microsoft Word™, PASCO Capstone workbook files with sample data, and graphics. Download these experiments at [www.pasco.com/CapstoneExperiments](http://www.pasco.com/CapstoneExperiments).

### Experiment Includes

- String Vibrator WA-9857
- Physics String SE-8050
- High Resolution Force Sensor PS-2189
- Large "C" Clamp
- Patch Cords (set of 5) SE-9750
- Tape Measure SE-8712A

### Order Information

- Vibrating String..... EX-5542
- Required:**
- 850 Universal Interface..... p. 12
- PASCO Capstone Software..... pp. 18-20

# Waves and Optics

## Waves

EX-9952

### Concepts:

- ▶ Speed of waves in a string
- ▶ Resonance in strings and air columns
- ▶ Speed of sound in air
- ▶ Harmonics



Standing waves in strings and air columns are studied. Using a sine wave generator to drive a string vibrator, the driving frequency, length, density, and tension of the string are varied to explore standing waves in strings and to determine the speed of the wave. For the sound waves in the air column, a speaker is used to drive a resonance tube. The driving frequency and the length of the tube are varied for both open and closed tubes. The relationship between resonant frequency modes and tube length is determined for closed versus open tubes.

### Experiment Includes

- String Vibrator WA-9857
- Sine Wave Generator WA-9867
- Open Speaker WA-9900
- Economy Resonance Tube WA-9495
- Elastic Wave Cord SE-9409
- Physics String SE-8050
- Yellow Braided Cord 699-067
- Mass and Hanger Set ME-8979
- Universal Table Clamp (2) ME-9376B
- Adjustable Angle Clamp ME-8744
- Super Pulley ME-9450
- Pulley Mounting Rod SA-9242
- 45 cm Rod (2) ME-8736
- Banana Plug Cord Set, Red SE-9750
- Waves Experiment Manual

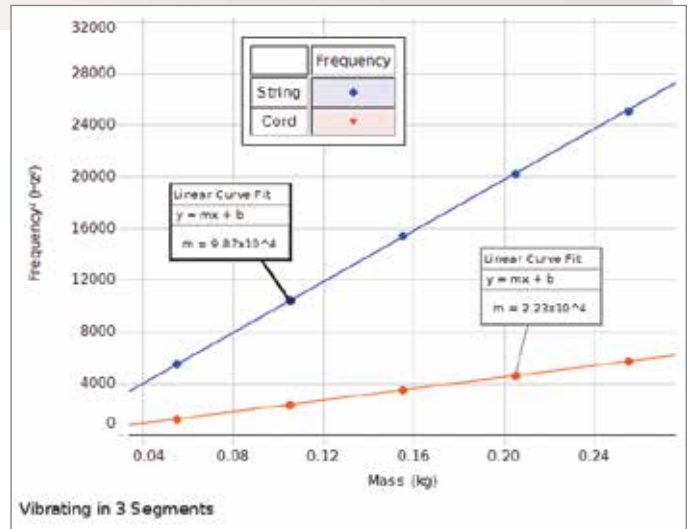

Graphs of the square of the frequency versus the hanging mass for two different types of strings have different slopes corresponding to different string densities.

### PASCO Advantage

The frequency of the vibration of the string is not limited to the line frequency, so the frequency can be varied as well as the length and the tension.

### To Download The Manual

Search for EX-9952 at [www.pasco.com](http://www.pasco.com)

### Order Information

Waves .....EX-9952

## Reflection and Refraction

EX-9987

### Concepts:

- ▶ Reflection and refraction
- ▶ Index of refraction

Students experimentally derive the Law of Reflection for curved and flat mirrors. Snell's Law is explored and the index of refraction for a piece of acrylic material is found.

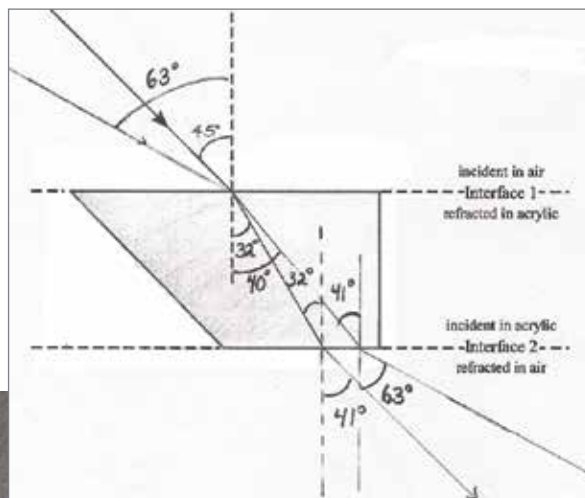

Sample of student work, showing the path of two different rays passing through the acrylic rhomboid.

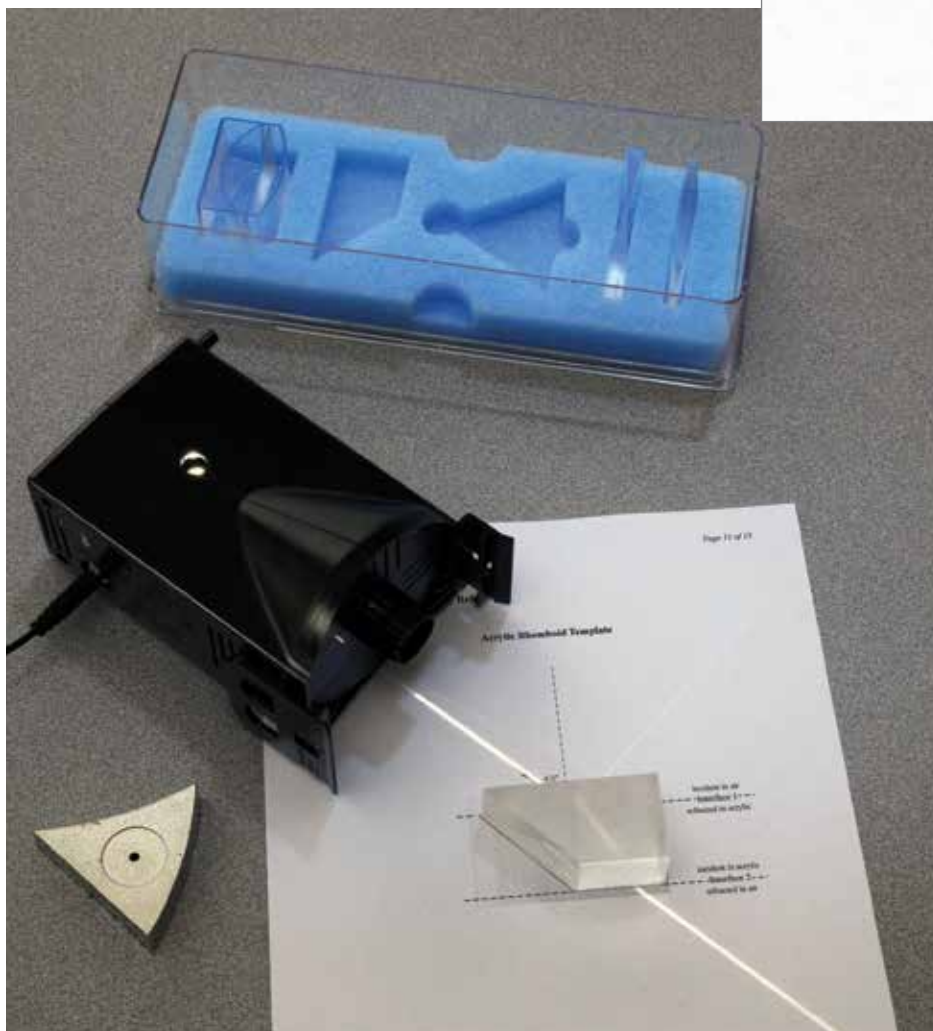

### PASCO Advantage

Students trace the rays on the provided templates and make angle measurements directly from their drawing. This reinforces the connection between the real rays they can see in the lab and the type of ray diagrams seen in the classroom.

### Experiment Includes

- Ray Optics Kit OS-8516A
- Basic Optics Light Source OS-8470
- Reflection and Refraction Experiment Manual

### Order Information

Reflection and Refraction..... EX-9987

Required:  
Protractor and Ruler

### To Download The Manual

Search for EX-9987 at [www.pasco.com](http://www.pasco.com)

# Waves and Optics

## Speed of Light

EX-9932A

Concepts:

- ▶ Determine the Speed of Light in Air
- ▶ Recreate Foucault's Historical Experiment

CLASS II LASER PRODUCT  
LASER RADIATION – DO NOT STARE INTO BEAM OR  
VIEW DIRECTLY WITH OPTICAL INSTRUMENTS



The Speed of Light Experiment uses laser light and a high-speed rotating mirror to determine this fundamental constant using the Foucault method.

Laser light passes through a series of lenses to produce an image of the light source at a measured position. The light is then directed to a rotating mirror, which reflects the light to a fixed mirror at a known distance from the rotating mirror. The laser light is reflected back through its original path and a new image is formed at a slightly different position. The difference between final/initial positions, angular velocity of the rotating mirror, and distance traveled by the light are then used to calculate the speed of light in air.

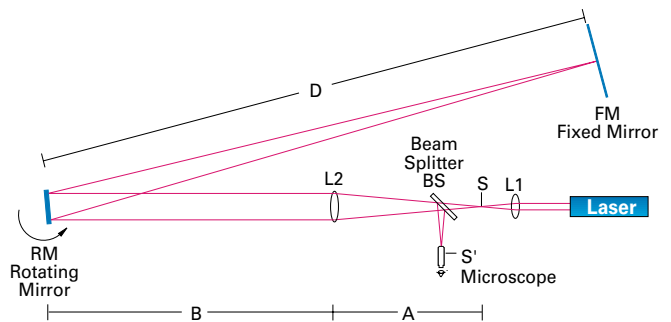

### PASCO Advantage

PASCO's Speed of Light Experiment allows students to experimentally measure the speed of light within 5% of the accepted value. In addition, the experiment can be performed on a desktop or in a hallway.

### Experiment Includes

- Complete Speed of Light Apparatus
- Speed of Light Experiment Manual

OS-9261B

### To Download This Experiment

Search for EX-9932A at [www.pasco.com](http://www.pasco.com)

### Order Information

Speed of Light.....EX-9932A

## Telescope/Microscope

EX-9988

### Concepts:

- ▶ Multiple lens systems
- ▶ Magnification
- ▶ Parallax
- ▶ Description of images

Students construct an astronomical telescope, a Galilean telescope, and a compound microscope on the optical bench. Using a viewing screen with grid, they find and describe the ways in which images are changed by the multiple lens systems.

The parallax method is used to locate virtual images. Students draw ray diagrams and measure the magnification of the instruments.

*Cross-hatched screen pattern from provided template allows students to easily observe and measure the resulting magnification.*

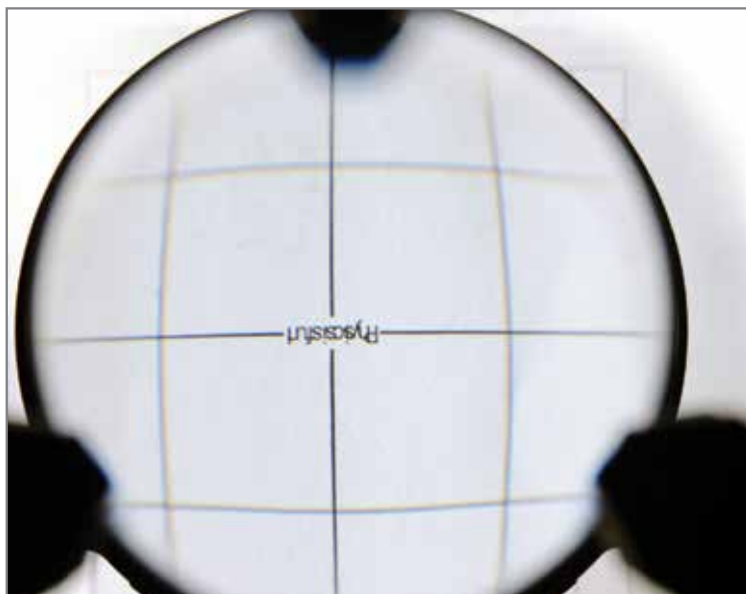

Actual view through the lens of magnified screen when used as a microscope

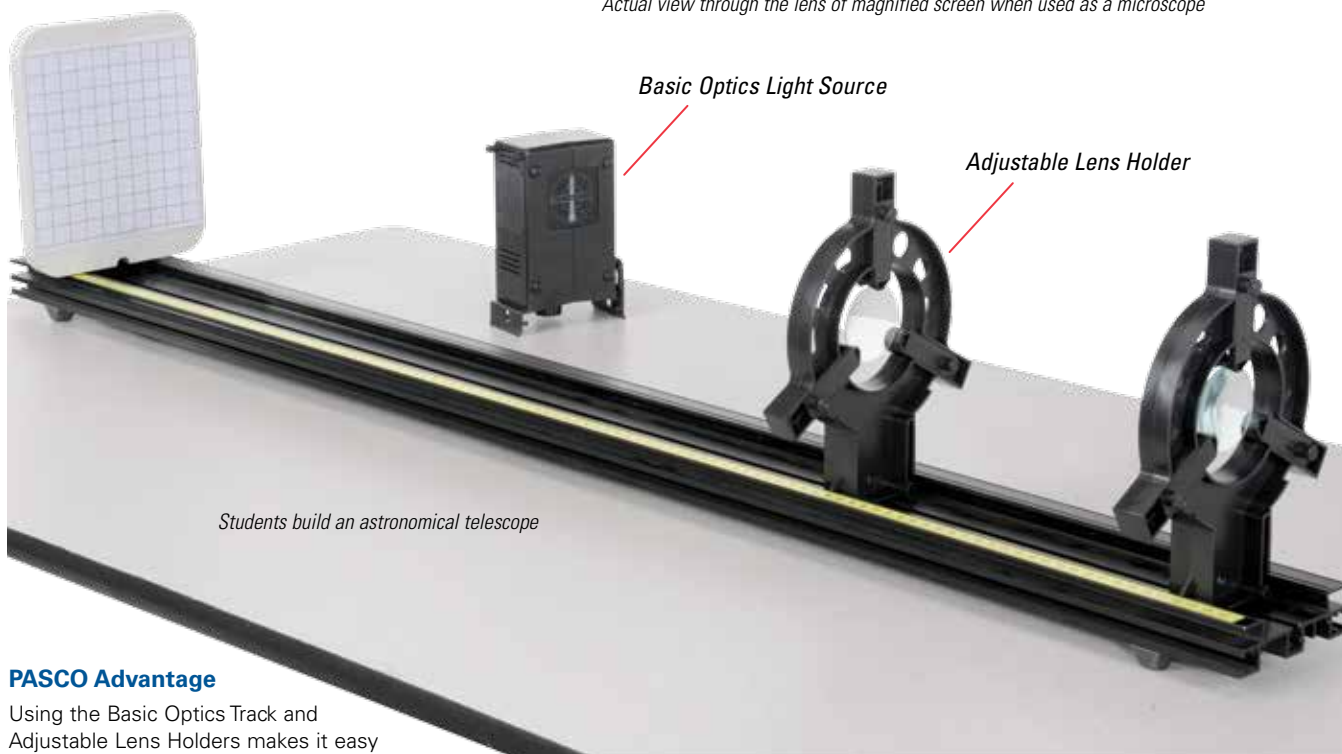

### PASCO Advantage

Using the Basic Optics Track and Adjustable Lens Holders makes it easy for students to quickly build each of the instruments. Open construction means that all students can see the location and types of lenses used.

### Experiment Includes

- Beginning Optics System OS-8459  
Includes:
  - Basic Optics Light Source OS-8470
  - Adjustable Lens Holders (2) OS-8474
  - Geometric Lens Set OS-8466A
  - Viewing Screen OS-8460
  - 1.2 m Optics Bench OS-8508

### To Download This Experiment

Search for EX-9988 at [www.pasco.com](http://www.pasco.com)

### Order Information

Telescope and Microscope .....EX-9988  
 Required:  
 Rubber Bands and Ruler

# Waves and Optics

## Polarization of Light

EX-5543A

### ▶ Malus' Law of Polarization

Designed for use with any of the following:

- ▶ 850 Universal Interface
- ▶ 550 Universal Interface
- ▶ Any PASPORT interface with 2 ports

In this experiment, Malus' Law of Polarization is verified by showing that the intensity of light passed through two polarizers depends on the square of the cosine of the angle between the two polarization axes.

Laser light (peak wavelength = 650 nm) is passed through two polarizers. As the second polarizer (the analyzer) is rotated by hand, the relative light intensity is recorded as a function of the angle between the axes of polarization of the two polarizers. The angle is obtained using a Rotary Motion Sensor coupled to the polarizer with a drive belt. The plot of light intensity versus angle can be fitted to the square of the cosine of the angle.

CLASS 2 LASER PRODUCT  
LASER LIGHT – DO NOT STARE INTO BEAM

A laser beam passes through two polarizers to a Light Sensor.

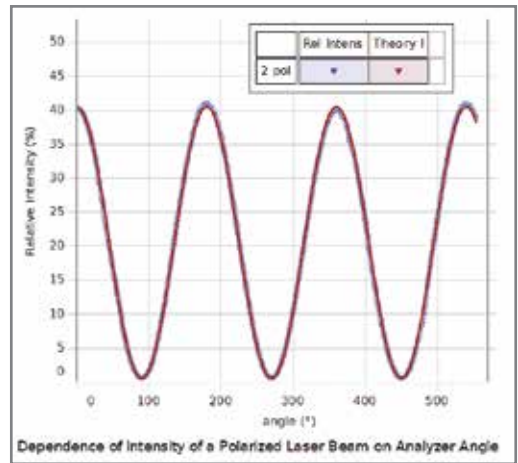

As the polarizer is rotated, the intensity of the light varies as the square of the cosine of the angle between the two polarizers.

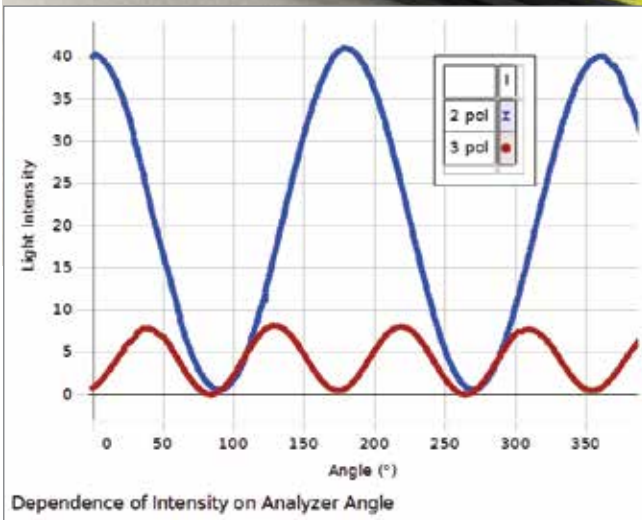
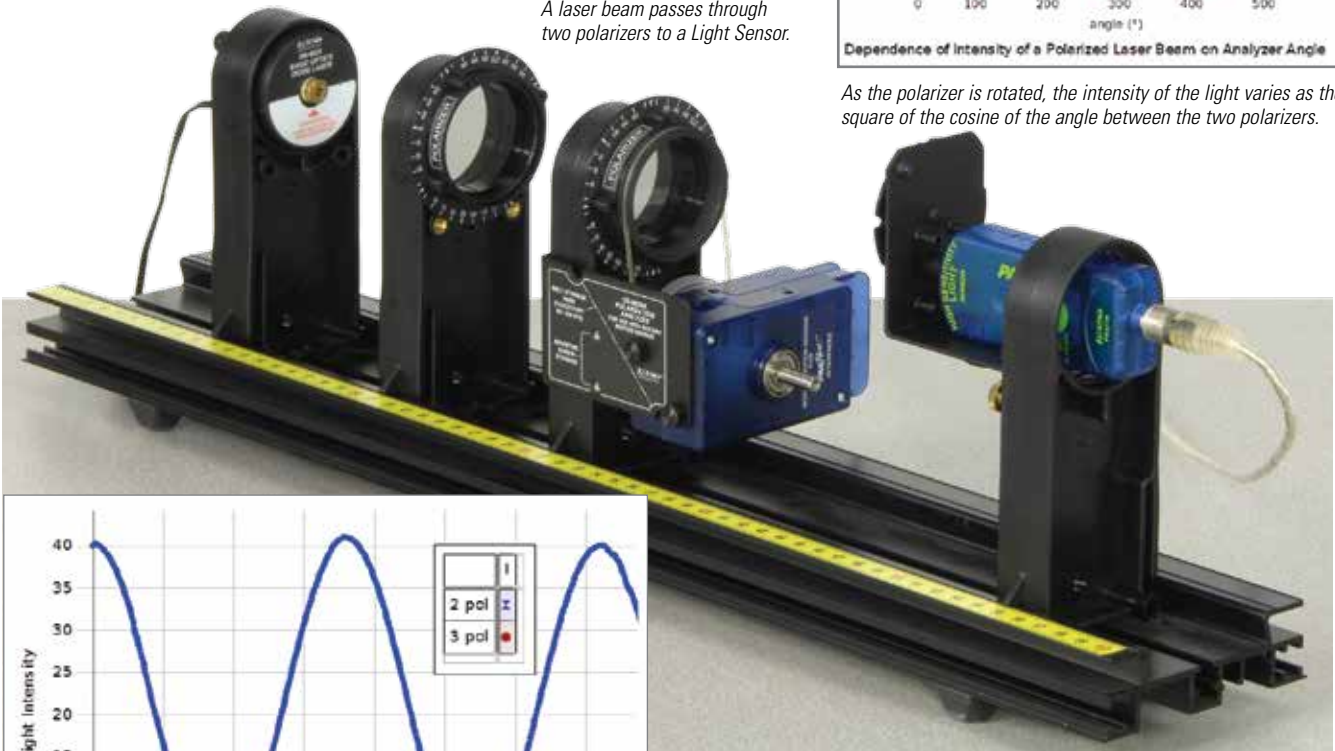

A three polarizer system can be produced using the fact that the laser is polarized. The data (red trace) at left shows that there are four oscillations per full rotation for a three polarizer system.

### PASCO Advantage

Laser light is used in this experiment because its wavelength is more completely extinguished by the crossed polarizers.

### Experiment Includes

- Polarization Analyzer OS-8533A
- Basic Optics Bench (60 cm) OS-8541
- Red Diode Laser OS-8525A
- High Sensitivity Light Sensor PS-2176
- Rotary Motion Sensor PS-2120A

### Download This Experiment

The FREE experiment files include instructions in Microsoft Word™, PASCO Capstone workbook files with sample data, and graphics. Download these experiments at [www.pasco.com/CapstoneExperiments](http://www.pasco.com/CapstoneExperiments).

### Order Information

Polarization of Light.....EX-5543A

Required:

550 or 850 Universal Interface\*..... pp. 12-14  
PASCO Capstone Software..... pp. 18-20

\* This experiment can be performed using the 550 or 850 Universal Interface or any PASPORT interface with two ports.

## Brewster's Angle

EX-5544A

Designed for use with any of the following:  
 ▶ 850 Universal Interface ▶ Any PASPORT interface with 3 ports

CLASS 2 LASER PRODUCT  
 LASER LIGHT – DO NOT STARE INTO BEAM

### Concepts:

- ▶ Polarization by reflection
- ▶ Brewster's Angle
- ▶ Fresnel's Law of Reflection
- ▶ Snell's Law

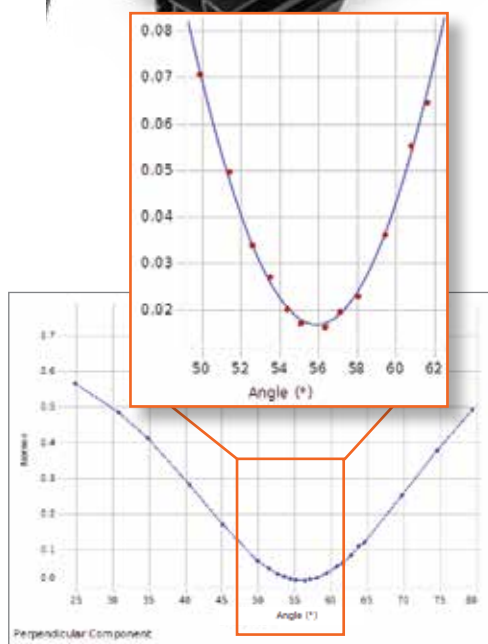
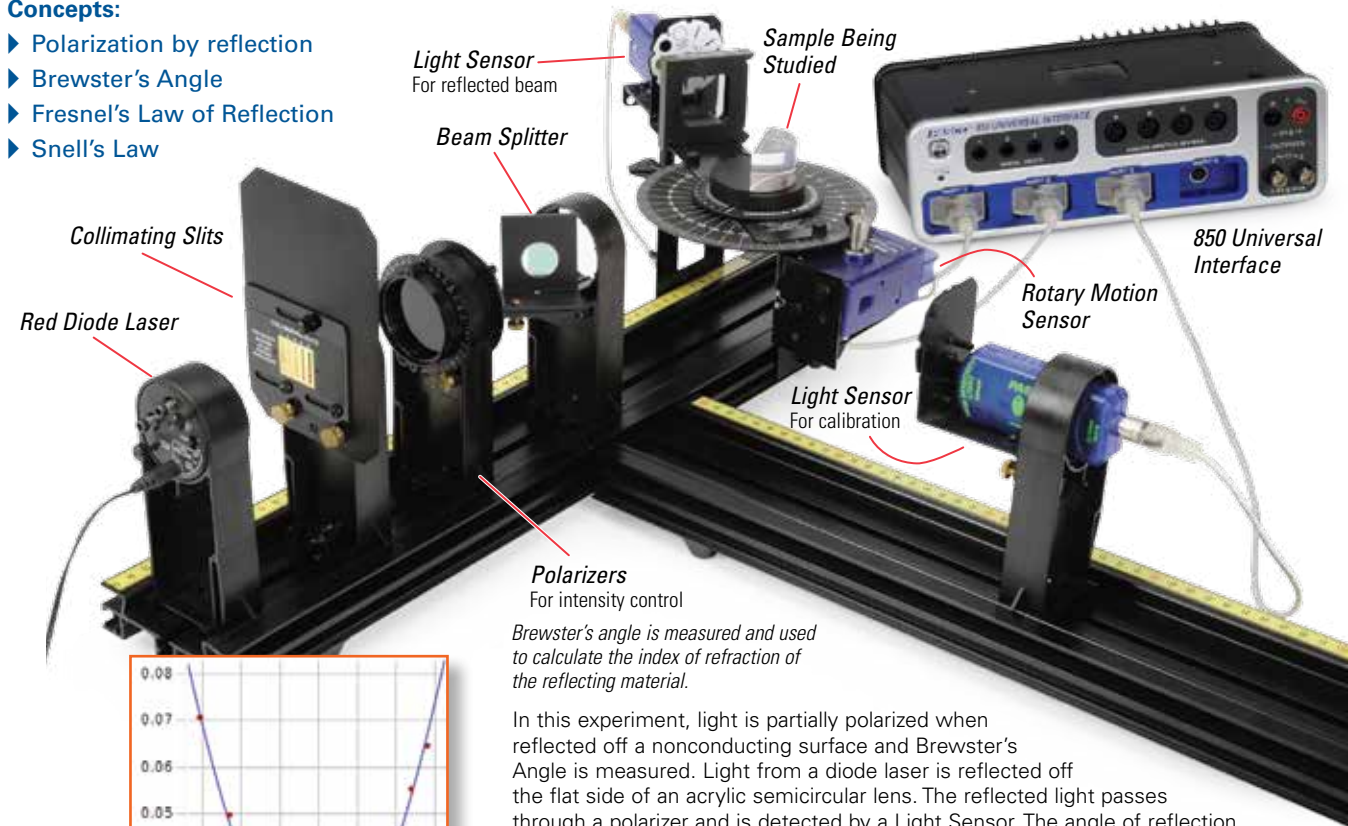

**Polarizers**  
 For intensity control

*Brewster's angle is measured and used to calculate the index of refraction of the reflecting material.*

In this experiment, light is partially polarized when reflected off a nonconducting surface and Brewster's Angle is measured. Light from a diode laser is reflected off the flat side of an acrylic semicircular lens. The reflected light passes through a polarizer and is detected by a Light Sensor. The angle of reflection is measured by a Rotary Motion Sensor mounted on the Spectrophotometer table. The intensity of the reflected polarized light versus reflected angle is graphed to determine the angle at which the light intensity is a minimum. This is Brewster's Angle, which is used to calculate the index of refraction of acrylic.

### PASCO Advantage

It is possible to determine the difference in index of refraction for different wavelengths of light. This is accomplished by using a beam-splitter and a second light sensor to compensate for the variation of the laser intensity. The reflected beam intensity is normalized by the intensity of the laser. This modification to the experiment was suggested by Cristian Bahrim and Wei-Tai Hsu in the American Journal of Physics article: "Precise Measurement of the Refractive Indices for Dielectrics Using an Improved Brewster Angle Method," Vol. 77, page 337 (2009).

*Developed using original ideas from P.J. Ouseph, Professor of Physics at University of Louisville, KY: "Polarization of Light by Reflection and the Brewster Angle" by P.J. Ouseph, Kevin Driver, and John Conklin, Am. J. Phys. 69, 1166 (2001).*

*Brewster's Angle is determined by finding the angle at which no light is transmitted through the analyzing polarizer.*

### Experiment Includes

- Brewster's Angle Accessory OS-8170A
- Spectrophotometer Accessory Kit OS-8537
- Optics Bench (60 cm) (2) OS-8541
- Rotary Motion Sensor PS-2120A
- High Sensitivity Light Sensor (2) PS-2176
- Aperture Bracket for Light Sensor (2) OS-8534A
- Red Diode Laser OS-8525A
- Polarizer Set OS-8473

**Download This Experiment**

The FREE experiment files include instructions in Microsoft Word™, PASCO Capstone workbook files with sample data, and graphics. Download these experiments at [www.pasco.com/CapstoneExperiments](http://www.pasco.com/CapstoneExperiments).

**Order Information**

Brewster's Angle..... EX-5544A

**Required:**

850 Universal Interface\*..... p. 12

PASCO Capstone Software..... pp. 18-20

\* This experiment can be performed using the 850 Universal Interface or any PASPORT interface with three ports.

# Waves and Optics

## Light Intensity vs. Distance

EX-5547A

In this experiment the student measures intensity as a function of distance from a point of source and from an extended (5 cm x 5 cm) source. Manipulation of a computer model verifies that for the point source, the intensity drops off like an inverse square. But for the extended source the data cannot be fit by an inverse square relationship

### PASCO Advantage

As the student slides the light sensor away from the Light Source, the Optics Track keeps everything aligned. The Rotary Motion Sensor measures the position, allowing the intensity vs. distance graph to be plotted in real-time. Students immediately see the relationship between distance and intensity of light.

Designed for use with any of the following:

- ▶ 850 Universal Interface
- ▶ 550 Universal Interface
- ▶ Any PASPORT interface with 2 ports

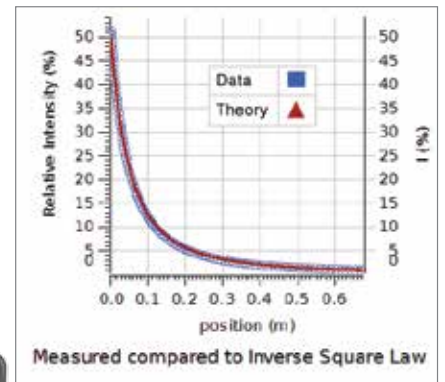

String over Rotary Motion Sensor Pulley allows measurement of the position of the Light Sensor.

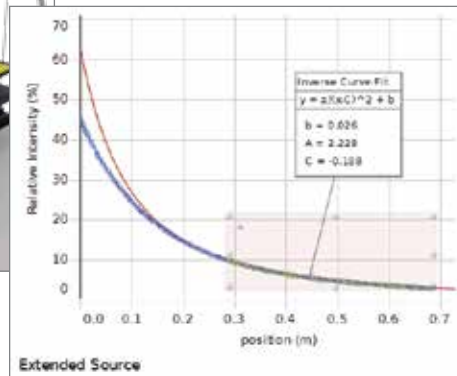
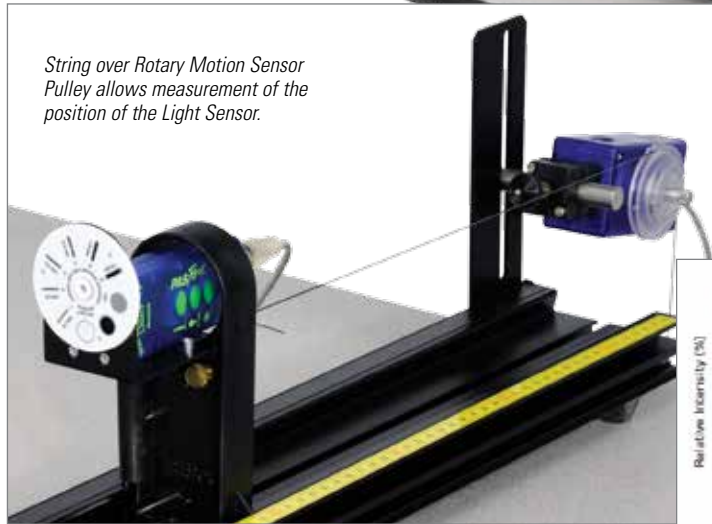

Students learn that only a point source falls off as the inverse square of distance. The light source's large crossed arrow target (on back side) doesn't start to look like a point source until the light detector is about 0.5 m away.

### Experiment Includes

- 120 cm Optics Bench OS-8508
- Basic Optics Light Source OS-8470
- Aperture Bracket OS-8534A
- 20 g hooked mass (Hooked Mass Set) SE-8759
- Thread 699-011
- High Sensitivity Light Sensor PS-2176
- Rotary Motion Sensor PS-2120A
- Dynamics Track Mount CI-6692

### Download This Experiment

The FREE experiment files include instructions in Microsoft Word™, PASCO Capstone workbook files with sample data, and graphics. Download these experiments at [www.pasco.com/CapstoneExperiments](http://www.pasco.com/CapstoneExperiments).

### Order Information

Light Intensity vs. Distance.....EX-5547A

Required:

550 or 850 Universal Interface\*.....pp. 12-14  
 PASCO Capstone Software.....pp. 18-20

\* This experiment can be performed using the 550 or 850 Universal Interface or any PASPORT interface with two ports.

## Interference and Diffraction of Light

EX-5545A

### Concepts:

- ▶ Two-slit interference
- ▶ Multiple-slit minor maxima
- ▶ Single-slit diffraction
- ▶ Slit versus line diffraction

Interference and diffraction patterns from laser light passing through various single-slits and multiple-slits are scanned and plotted in real-time. These patterns are then examined for similarities and differences.

The distances between the central maximum and the diffraction minima for a single slit are measured by scanning the laser pattern with a Light Sensor and plotting light intensity versus distance. Also, the distances between interference maxima for two or more slits are measured. These measurements are compared to theoretical values. Differences and similarities between interference and diffraction patterns are examined.

### PASCO Advantage

Since the Linear Translator tracks the position of the Light Sensor, it is not necessary to move the Light Sensor at a constant speed. The intensity versus distance graph is plotted in real-time, showing the connection between the intensity pattern and the actual laser pattern. Adjustment of the slit size on the Light Sensor mask gives the resolution required to see detail in the interference patterns.

Designed for use with any of the following:

- ▶ 850 Universal Interface
- ▶ 550 Universal Interface
- ▶ Any PASPORT interface with 2 ports



The laser interference pattern is scanned by hand with a Light Sensor on a Linear Translator.



CLASS 2 LASER PRODUCT  
LASER LIGHT – DO NOT  
STARE INTO BEAM

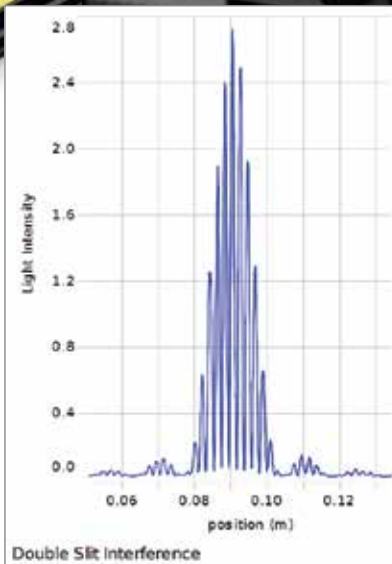
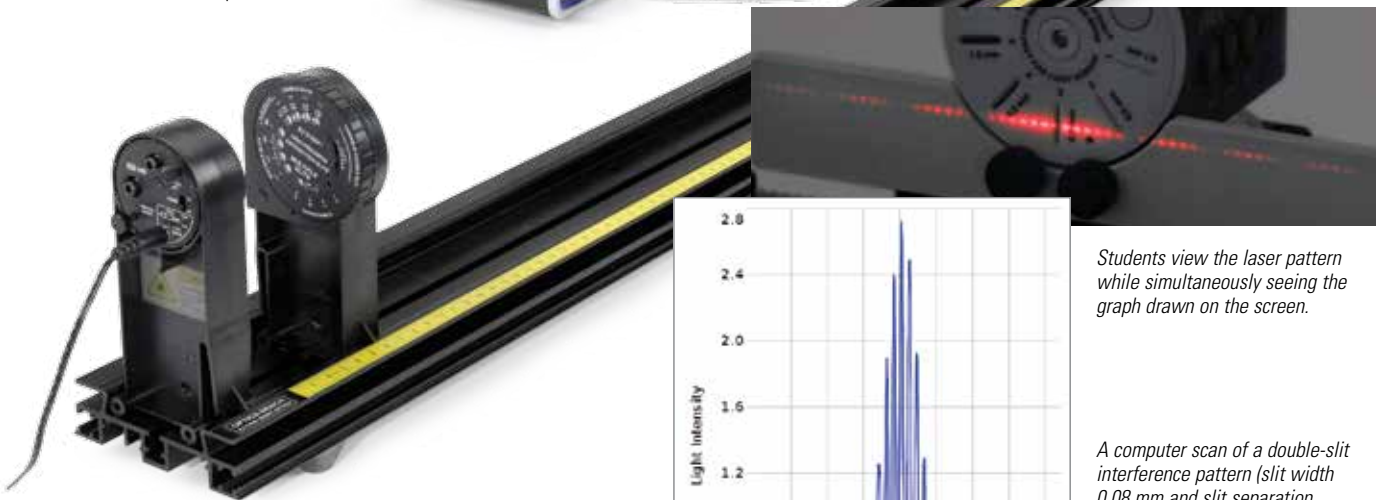

Students view the laser pattern while simultaneously seeing the graph drawn on the screen.

A computer scan of a double-slit interference pattern (slit width 0.08 mm and slit separation 0.50 mm) is shown at left. A photograph of the actual laser pattern is shown above.

### Experiment Includes

- Basic Optics Track, 1.2 m OS-8508
- High Precision Diffraction Slits OS-8453
- Basic Optics Diode Laser OS-8525A
- Aperture Bracket OS-8534A
- Linear Translator OS-8535
- High Sensitivity Light Sensor PS-2176
- Rotary Motion Sensor PS-2120A

### Order Information

Interference and Diffraction of Light.....EX-5545A

#### Required:

550 or 850 Universal Interface\* ..... pp. 12-14  
 PASCO Capstone Software ..... pp. 18-20

\* This experiment can be performed using the 550 or 850 Universal Interface or any PASPORT interface with two ports.

### Download This Experiment

The FREE experiment files include instructions in Microsoft Word™, PASCO Capstone workbook files with sample data, and graphics. Download these experiments at [www.pasco.com/CapstoneExperiments](http://www.pasco.com/CapstoneExperiments).

# Quantum

## Atomic Spectra

EX-5546B

### Concepts:

- ▶ Hydrogen balmer series
- ▶ Helium spectrum
- ▶ Mercury doublet

The wavelengths of the discrete lines of the atomic spectra of various gases are measured using a grating spectrophotometer.

The atomic spectra of hydrogen, helium, and mercury are scanned by hand using a grating spectrophotometer, which measures relative light intensity as a function of angle. From the resulting graph, the wavelengths of the spectral lines are determined by measuring the angle from the central maximum to each line. First and second order lines are examined.

The wavelengths of the spectral lines are compared to the accepted values and, in the case of hydrogen, the electron orbit transitions corresponding to the lines are identified.

Designed for use with any of the following:

- ▶ 850 Universal Interface
- ▶ 550 Universal Interface
- ▶ Any PASPORT interface with 2 ports

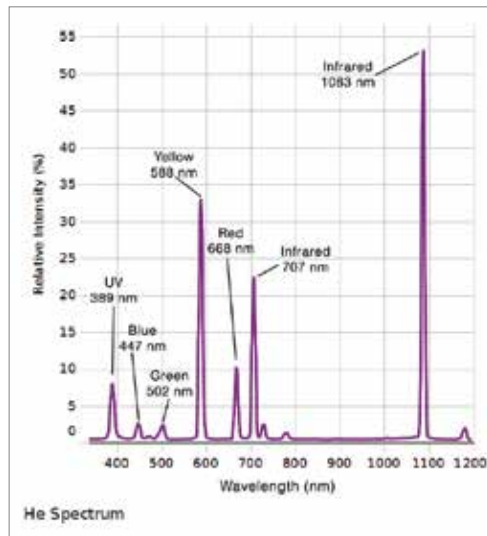

The spectral lines of helium are scanned.

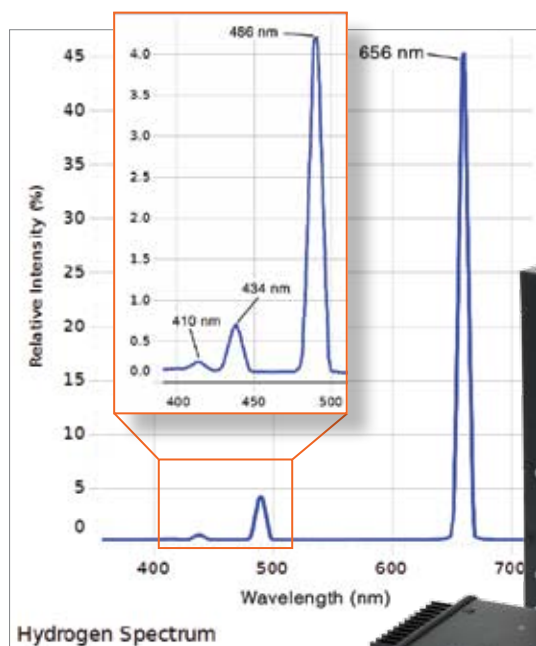
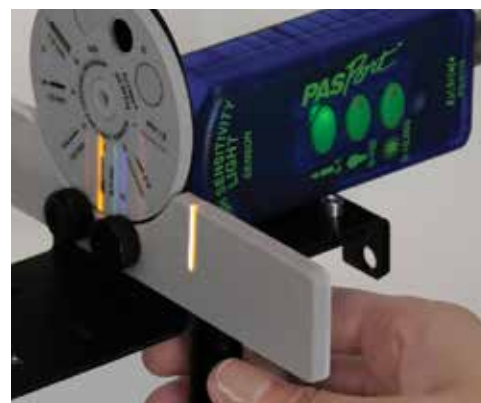

The four brightest lines of the Balmer series for hydrogen.

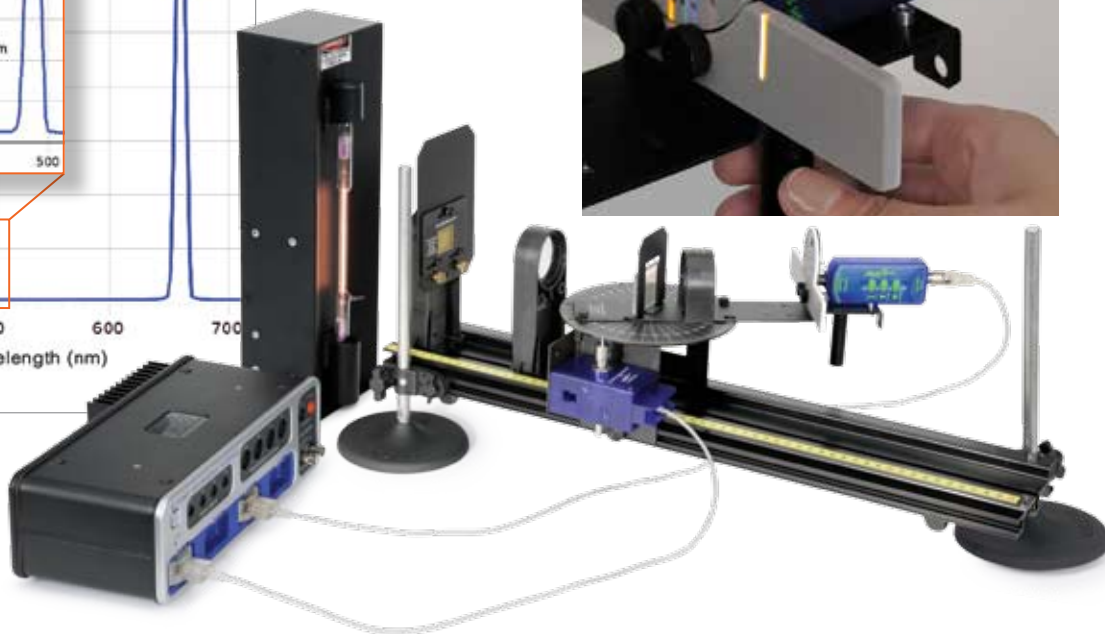

### PASCO Advantage

The open construction of the spectrophotometer allows the entire spectrum to be seen, while the intensity versus angle is graphed in real-time.

### Experiment Includes

- Spectrophotometer Accessory Kit OS-8537
- 60 cm Optics Bench OS-8541
- Aperture Bracket OS-8534A
- High Sensitivity Light Sensor PS-2176
- Rotary Motion Sensor PS-2120A
- Round Base with Rod (2) ME-8270
- Spectral Tube Power Supply and Mount SE-9460
- Hydrogen Spectral Tube SE-9461
- Helium Spectral Tube SE-9462
- Mercury Spectral Tube SE-9466

### Download This Experiment

The FREE experiment files include instructions in Microsoft Word™, PASCO Capstone workbook files with sample data, and graphics. Download these experiments at [www.pasco.com/CapstoneExperiments](http://www.pasco.com/CapstoneExperiments).

### Order Information

Atomic Spectra .....EX-5546B

Required:

550 or 850 Universal Interface\* .....pp. 12-14

PASCO Capstone Software .....pp. 18-20

\* This experiment can be performed using the 550 or 850 Universal Interface or any PASPORT interface with two ports.

# Photoelectric Effect

EX-5549A

Designed for use with either of the following:

- ▶ 850 Universal Interface
- ▶ 550 Universal Interface

- ▶ Connects to the 850 Universal Interface for data collection in PASCO Capstone
- ▶ Find Planck's Constant to within 5%
- ▶ Verify that stopping voltage is independent of intensity
- ▶ Find characteristics of the photodiode

The Photoelectric Effect System is used to perform the photoelectric experiment, determining Planck's Constant to within 5%. This apparatus uses the conventional method of determining Planck's Constant. The metal plate in the photodiode is illuminated with various frequencies of light, selected from a mercury lamp using filters. The voltage is then adjusted to stop the photoelectric current. The stopping voltage is plotted versus the frequency, and Planck's Constant is determined from the slope of the graph.

The concept that the stopping voltage does not change with light intensity is tested using the various apertures that change the light intensity by partially blocking the light.

### Uses the 850 Universal Interface and PASCO Capstone to collect and analyze data.

Both the picoammeter and the power supply for the stopping voltage have sensor ports on the front that connect to the analog sensor ports of the 850 Universal Interface. PASCO Capstone automatically recognizes these instruments and can read the current and the voltage. During the experiment, each time a different filter is applied, the user clicks "Keep" in PASCO Capstone and the value of the stopping voltage for that frequency is recorded and automatically graphed versus frequency.

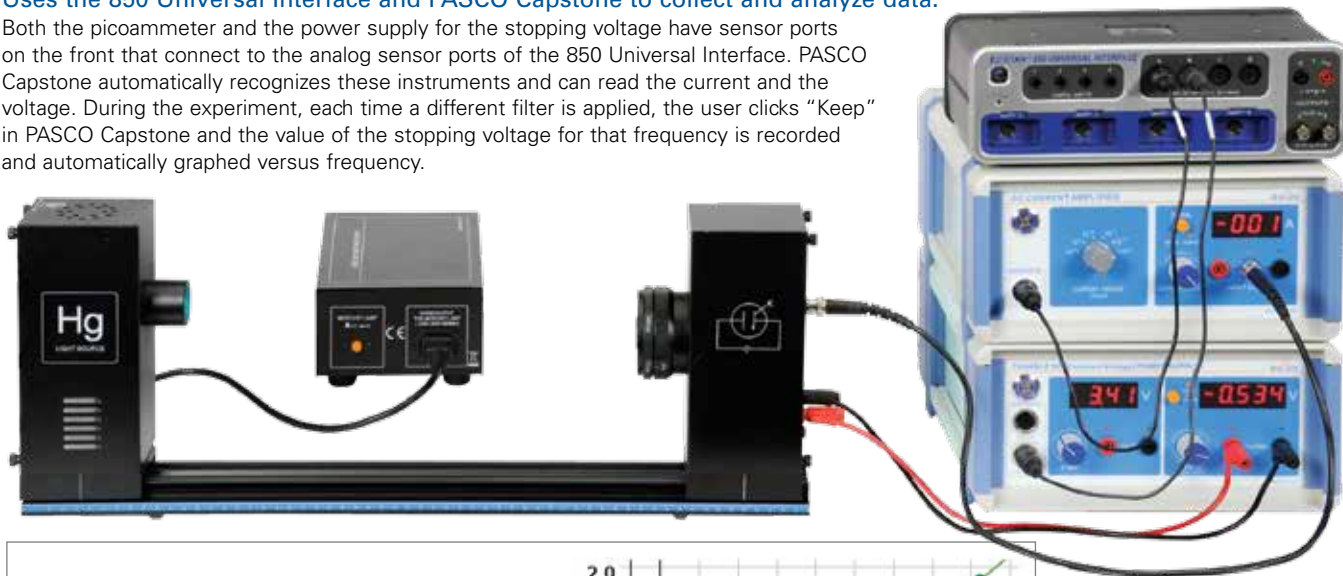
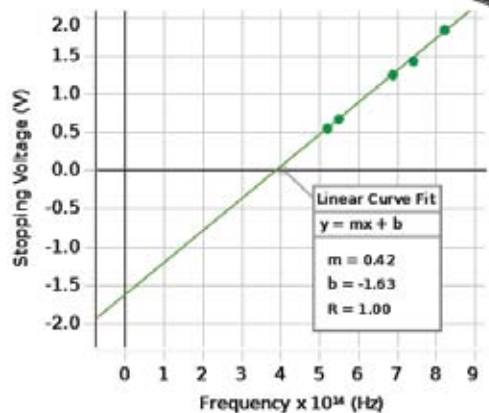

Table 1: Photoelectric Effect with 4 mm Aperture

	▲ Run #1	■ Run #1
	Frequency x 10 <sup>14</sup> (Hz)	Stopping Voltage (V)
1	8.214	1.835
2	7.408	1.428
3	6.879	1.248
4	5.490	0.671
5	5.196	0.551



For the typical sample data shown, the graph of stopping voltage versus frequency gives a slope of  $4.2 \times 10^{-15}$  V.s. This results in a value for Planck's Constant of  $6.7 \times 10^{-34}$  J.s, which is 1.3% above the accepted value. Graph generated using PASCO Capstone Software.

### Experiment Includes

- Photoelectric Effect Apparatus SE-6614
- DC Current Amplifier SE-6621
- Tunable DC Power Supply SE-6615
- Cables for 850 Interface

### Order Information

Photoelectric Effect.....EX-5549A

#### Required:

- 550 or 850 Universal Interface.....pp. 12-14
- PASCO Capstone Software.....pp. 18-20

### Download This Experiment

The FREE experiment files include instructions in Microsoft Word™, PASCO Capstone workbook files with sample data, and graphics. Download these experiments at [www.pasco.com/CapstoneExperiments](http://www.pasco.com/CapstoneExperiments).

# Oscillations

## Bridge Vibrations

EX-5548

Designed for use with the  
850 Universal Interface

Concepts:

- ▶ Resonance in complex systems
- ▶ Driven vs. free vibrations

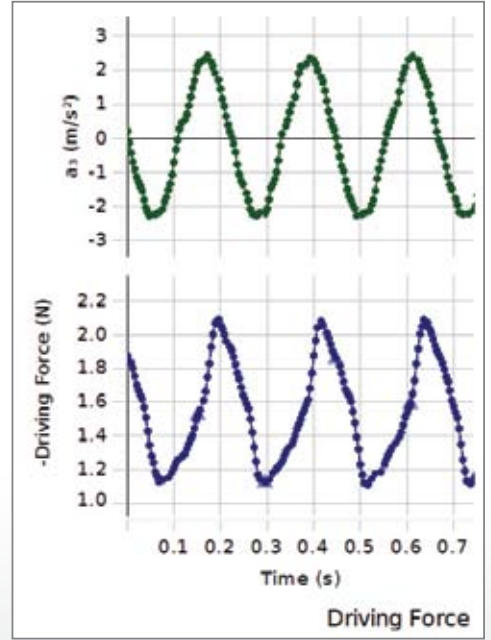

*Students compare the driving force to the resulting acceleration at different positions on the bridge.*

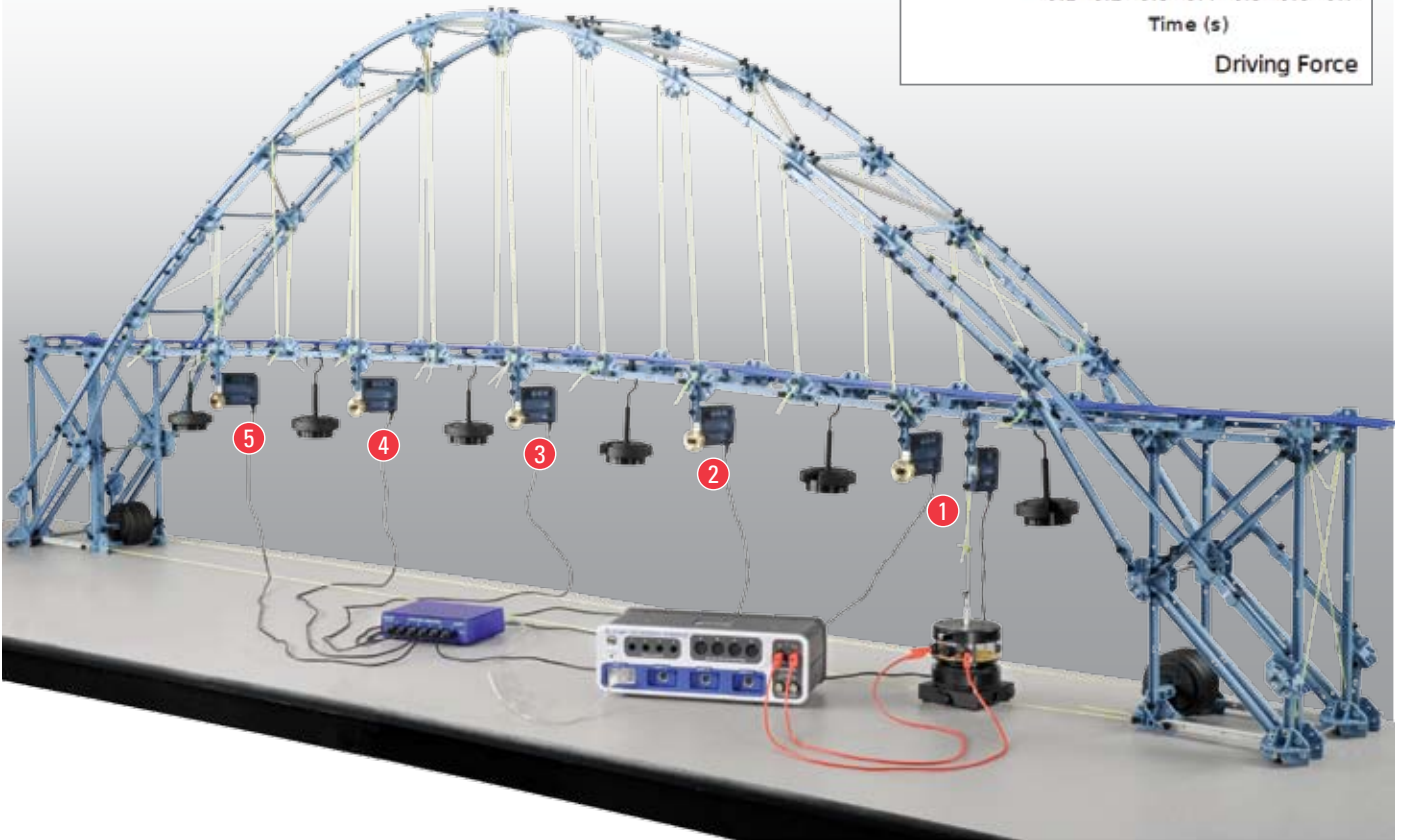

### Experiment Includes

- Large Structures Set
- Load Cell Amplifier
- 100 N Load Cell
- 5 N Load Cell (5)
- Mechanical Wave Driver

- ME-7003
- PS-2198
- PS-2200
- PS-2201
- SF-9324

- 4 mm Banana Plug Cords-Red
- Rubber Cord
- Large Slotted Mass Set (4)
- Short Mass Hanger (2)
- 20 g Masses (3 sets of 6)

- SE-9750
- ME-8986
- ME-7589
- ME-7590
- ME-8983

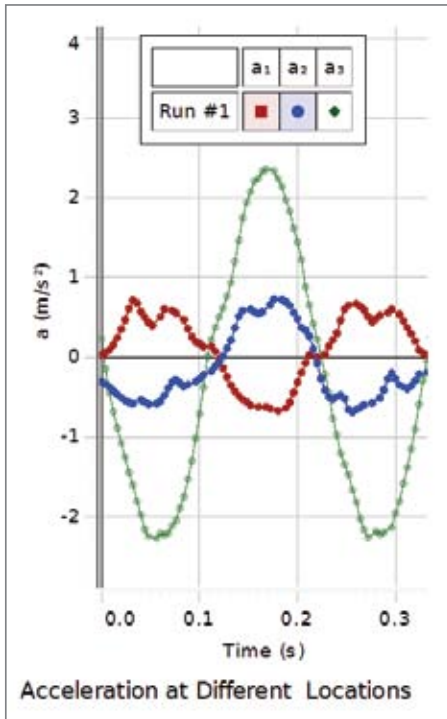

The 5 N Load Cells are used to measure the oscillations of the bridge at several different positions.

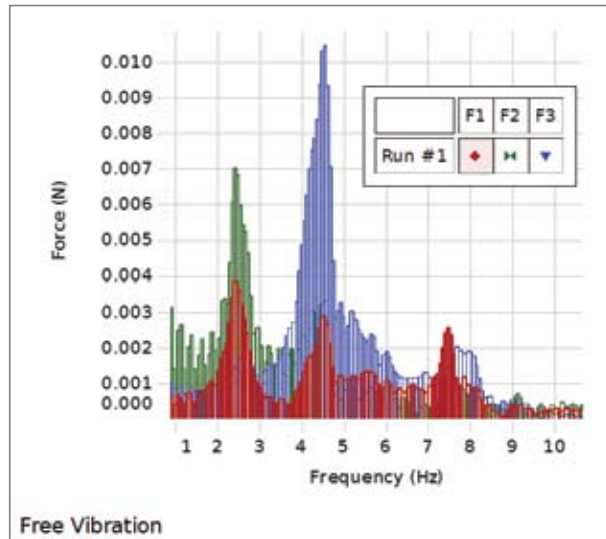

The bridge is struck by hand and allowed to freely oscillate. The FFT (using PASCO Capstone™) shows that there are several resonant frequencies. Note how different the amplitudes are at different locations on the bridge.

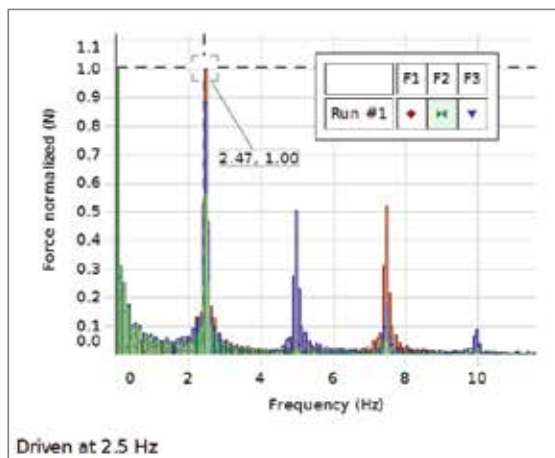

The resonance of the bridge is characterized by driving the bridge at different resonant frequencies. Note how different the amplitudes are at different locations on the bridge.

**Download This Experiment**

The FREE experiment files include instructions in Microsoft Word™, PASCO Capstone workbook files with sample data, and graphics. Download these experiments at [www.pasco.com/CapstoneExperiments](http://www.pasco.com/CapstoneExperiments).

**Order Information**

- Bridge Vibrations ..... EX-5548
- Required:
- 850 Universal Interface ..... p. 12
- PASCO Capstone Software ..... pp. 18-20

# Educators Trust PASCO Professional Development...



**PASCO's Professional Development** provides teachers with the training, guidance, and innovative solutions they need to lead sensor-based science lessons. Our trainers are curriculum experts who model how to confidently guide students through inquiry-based science lessons.

**PASCO training sessions are relevant for teachers at all grade levels.** Trainings include classroom-ready activities aligned to STEM-based standards and national and state correlations for:

- *Elementary and Middle School sciences*
- *High school and higher education Biology, Chemistry, Earth Science, Environmental Science, Physical Science, and Physics*
- *Advanced, AP<sup>®</sup>, and IB<sup>®</sup> courses in Biology, Chemistry, Environmental Science, and Physics\**

**PASCO PD is fully customizable** and tailored to your scope and sequence, so you get affordable training that fits your curriculum.

**Our PD includes ongoing teacher support** and a free follow-up webinar. PASCO PD isn't just a one-time workshop. Our trainers provide their ongoing support and expertise, whenever and wherever you need it.

***"When educators learn, students learn more."***

*Hayes Mizell, in "Why Professional Development Matters."  
Written for Learning Forward.  
[http://www.learningforward.org/docs/pdf/why\\_pd\\_matters\\_web.pdf](http://www.learningforward.org/docs/pdf/why_pd_matters_web.pdf)*



\*AP is a registered trademark of the College Board, which was not involved in the production of, and does not endorse, this product. IB is a registered trademark of the International Baccalaureate Organization, which was not involved in the production of, and does not endorse, this product.

# What a PASCO Professional Development plan provides for you, your school, and your district...

## 1 Student-centered, classroom-ready lab activities for all the sciences

Our labs range from structured-inquiry to open-inquiry. They can be used on multiple platforms including iPad®, Android™ tablets, Chromebook™, and Mac®.

With them, teachers can:

- Integrate technology into the classroom, while showing students better ways to collect data.
- Engage students and make data meaningful for them while they *do* science.

## 2 Customizable delivery options and training formats that fit your needs

We custom-design the training to suit your individual requirements. Training programs include:

- Training onsite at your school
- Support in the classroom while you teach
- Webinar-based training
- Train-the-trainer
- Summer institutes

## 3 Skills development

PASCO's PD approach is to help you create a solid foundation for STEM success, as students develop these fundamental skills underlying science content standards:

- Critical thinking skills
- Procedural expertise
- Proficiency in design and construction of lab experiments
- Analytical skills
- Inquiry-based learning leading to science literacy

## 4 Skills necessary to implement your Science Standards

PASCO's trainers will show you how to use probeware to effectively engage students in scientific and engineering practices, while addressing disciplinary core ideas and crosscutting concepts.



## Replacement Parts

Part For:	Part #	Part Description	Page	Part For:	Part #	Part Description	Page
Amusement Park Physics	ME-8734	Springs, Accelerometer	121	Franck-Hertz Apparatus	SE-9645	Argon Tube	289
Balance, Ohaus	SE-8708	Mass Set, Ohaus Additional	186	Generator, Mini	EM-8814	Light Bulb	218
Blackbody	SE-8509	Replacement Bulbs for Blackbody	276	Goniometer	PS-2138	Goniometer Probe	67, 139
Calorimetry Set, Basic	TD-8825A	Calorimetry Cups	193	Goniometer	PS-2547	Velcro® Straps	139
Cart Launcher, Spring	ME-6847	Springs, Cart Launcher	106	Gravitational Torsion Balance	AP-8219	Grav Torsion Balls	292
Carts	ME-6957	Replacement Axles (4 pack)	111	Gravitational Torsion Balance	AP-8218	Grav Torsion Balance Bands	292
CASTLE Kits	EM-8655	Capacitor, 0.1 F	214	Gyroscope	ME-8961	Gyro Disk and Mass	168
CASTLE Kits	EM-8632	Capacitors (0.025 F, 2 pack)	214	Heat Engine Experiment	ME-7559	Container Set, 3 Liter Plastic	185
CASTLE Kits	EM-8630	Light Bulb Sockets (10 Pack)	214	Heat Engine/ Gas Law Apparatus	TD-8581A	Heat Engine Accessory	199
CASTLE Kits	EM-8628	Light Bulbs (#48, 25 pack)	214	Hooke's Law Set	SE-8749	Spring Set, Hooke's Law	155
CASTLE Kits	EM-8631A	Liquid Filled Compasses (5 Pack)	214	Launcher, Mini Projectile	ME-9872	Balls, Small Steel	129, 183
Circuit, AC/DC Electronics Laboratory	EM-8668	Electronic Components	212	Launchers, Large Projectile	ME-6822	Balls, Plastic	129, 183
Circuit, Basic Electricity	EM-8663	Electronic Components	213	Launchers, Large Projectile	ME-9864	Balls, Steel	129, 183
Circuits	SE-9756	Alligator Clip Adapters	217	Launchers, Large Projectile	ME-8968A	Mass Set, Spherical	129, 164, 183
Circuits	EM-8785	Capacitor Pack	217	Launchers, Large Projectile	ME-9865A	Sights, Projectile Launcher	129
Circuits	SE-8626	Capacitor, 1F	217	Launchers, Projectile	SE-8693	Carbon Paper	126, 129, 184
Circuits	EM-8634	Leads, Alligator Clips	216	Launchers, Projectile	ME-9868A	Plumb Bobs, Projectile Launcher	129
Circuits	SE-9751	Patch Cords, Long Black	216	Mapper, Electric Field	PK-9031B	Conductive Ink Pen	205
Circuits	SE-9750	Patch Cords, Long Red	216	Mapper, Electric Field	PK-9025B	Conductive Paper - with Grid	205
Circuits	SE-7123	Patch Cords, Short	216	Mapper, Electric Field	PK-9026	Conductive Paper - No Grid	205
Circuits	EM-8784	Resistor Pack	217	Mechanical Equivalent of Heat	TD-8583	Mech Equiv Brush	194
Circuits	EM-8815	Switch Set	218	Mechanical Equivalent of Heat	TD-8582	Mech Equiv Cylinder	194
Circuits	EM-8627	Light Bulbs	218	Mechanics System, Microwave System	WA-9802	Microwave Mounting Stand	284
Cloud Chambers	SE-7945	Radioactive Needle Source, Pb-210	301	Microwave System	WA-9800A	Microwave Receiver	284
Colorimeter, PASPORT	PS-2509	Replacement Cuvettes/Cap	61, 73	Microwave System	WA-9801	Microwave Transmitter	284
Color Mixer	OS-8495	Color Mixer Accessory Kit	260	Multimeter with Thermometer	SB-9632	Thermocouple Probe	241
Compression Igniter	TD-8498A	Replacement Tubes	195	Optics System, Basic	OS-8508	1.2 m Optics Track	259
Dynamics Track	ME-8972	Adjustable Feet (2)	112	Optics System, Basic	OS-8510	Basic Optics Spares Kit	259
Dynamics Track	ME-9495A	Angle Indicator	112	Photogates	ME-9804	2 Cart Picket Fences	38, 97
Dynamics Track	ME-9823	Dynamics Systems Spares Kit	112	Photogates	PI-8117	Cable, Phone Jack Extender	39
Dynamics Track	ME-9836	Pivot Clamp	112	Photogates	ME-9806	Photogate Brackets (2)	38, 97
Dynamics Track	ME-8999	Dynamics Track Spring Set	111	Photogates	ME-9805	Photogate Stand	37
Dynamics Track	ME-8998	Elastic Bumper	24, 112				
Dynamics Track	ME-8971	End Stops (2)	112				
Dynamics Track	ME-9807	Friction Block, Dynamics Track	107				
Dynamics Track	ME-9448B	Super Pulley with Clamp	111, 137				
EKG Sensors	CI-6620	EKG Patches	66				
Eye Model, Human	OS-8476	Lens Replacement Set, Human Eye	264				
Force Sensors	ME-9884	Bumper Accessory Set	30				
Force Sensors	ME-9885A	Magnetic Bumper Set	30, 108				

Part For:	Part #	Part Description	Page
Resistance Apparatus	EM-8813	Wires, Resistance Replacement	215
Resonance Air Column	WA-9605	Replacement Speaker	249
Ring Launcher	EM-8662	Ring Launcher Accessories	223
Ripple Tank	WA-9898	Ripple Tank Replacement Set	243
Roller Coaster	ME-9813	Mini Car Set (3 cars)	120
Roller Coaster	ME-9815	Roller Coaster Spares Kit	120
Roller Coaster	ME-9814	Roller Coaster Track (9.1 m)	120
Sensors, PASPORT	PS-2500	PASPORT Extension Cable	22
Sensors, ScienceWorkshop	UI-5218	8-pin DIN Extender Cable	13, 22
Spirometer	PS-2522	Spirometer Mouth Pieces	68
Statics System	ME-9504	Statics Spares	135
Stress/Strain Apparatus	AP-8222	Plastic Test Coupons (40)	154
Stress/Strain Apparatus	AP-8223	Metal Test Coupons (50)	154
Structures	ME-6974	Mini Car Track Spares	147
Structures	ME-6983	Cast Beam Spares	146
Structures	ME-6984	Hydraulic & Pneumatic Structures	146
Structures	ME-6985	Flexible I-Beams	147
Structures	ME-6986	Structures Rod Clamps	147
Structures	ME-6987	Flat Beams	147
Structures	ME-6988A	Force Platform Bracket	147
Structures	ME-6993	Truss Set Members	147
Structures	ME-6994	Truss Set Screws	147
Structures	ME-6995	Roadbed Spares	147
Structures	ME-6996	Cord Lock Spares	147
Structures	ME-6997	Round Connector Spares	147
Structures	ME-6998A	Axle Spares	147
Structures	ME-6999A	Angle Connector Spares	147
Structures	ME-7002	Connector Spares	147
Structures	ME-7008	#6 I-Beam Spares	147
Tape Timer	ME-9284	Tape Timer Supplies	116
Temperature Sensors	PS-2153	Temperature Probe	45
Temperature Sensors	PS-2135	Temperature Probe, Fast Responses	45
Temperature Sensors	PS-2131	Temperature Probe, Skin/Surface	45
Turbidity Sensor	PS-2511	100 NTU Calibration Standard	74

Part For:	Part #	Part Description	Page
Van de Graaff Generator	SE-7355	Replacement Belt	204
Water Quality Colorimeter	EZ-2331	ezSample Snap Vial – Iron	75
	EZ-2333B	ezSample Snap Vial – Nitrate	75
	EZ-2334A	ezSample Snap Vial – Ammonium	75
	EZ-2337	ezSample Snap Vial – Phosphate	75
	EZ-2339A	ezSample Snap Vial – Chlorine	75
	EZ-2338	ezSample Field Titrators – Total Hardness	75
	EZ-2341	ezSample Field Titrators – CO2	75
	EZ-2340	ezSample Field Titrators – Alkalinity	75
Wave Drivers	SE-9409	Cord, Elastic Wave	184, 251
	ME-9876	Cord, Yellow	184
	ME-9875	Thread, Black	184
Wireless Colorimeter and Turbidity	SE-8739	Cuvettes and Caps	74
Wireless Spectrometer	SE-8739	Cuvettes and Caps	74

## Part Number Index

AP-8210A.....	286	EM-8634.....	216, 218	ES-9070.....	292	EX-5545A.....	353	ME-5716.....	93
AP-8211.....	286	EM-8642A.....	225	ES-9077.....	207	EX-5546B.....	354	ME-5717.....	93
AP-8212.....	286	EM-8644B.....	224	ES-9078A.....	56, 206	EX-5547A.....	352	ME-5718.....	93
AP-8215A.....	292	EM-8648B.....	230	ES-9079.....	207	EX-5548.....	356-357	ME-5719.....	93
AP-8218.....	292	EM-8652.....	55	ES-9080B.....	206	EX-5549A.....	355	ME-6569.....	26, 112
AP-8219.....	292	EM-8654.....	214	ET-8499.....	194	EX-5550.....	317	ME-6617.....	30
AP-8222.....	154	EM-8655.....	217	ET-8771B.....	220	EX-9909.....	318	ME-6622.....	30, 108
AP-8223.....	154	EM-8656.....	212	ET-8772.....	221	EX-9929A.....	334	ME-6666.....	38, 97
AP-8586.....	295	EM-8661.....	223	ET-8783.....	222	EX-9930B.....	333	ME-6667.....	71
CI-6504A.....	47	EM-8662.....	223	EX-5501.....	304	EX-9932A.....	348	ME-6668.....	71
CI-6506B.....	57	EM-8663.....	213	EX-5502.....	305	EX-9933.....	342	ME-6743.....	24, 108
CI-6512.....	211	EM-8667.....	211	EX-5503A.....	306	EX-9935.....	314	ME-6755.....	111
CI-6520A.....	55	EM-8668.....	212	EX-5504A.....	307	EX-9952.....	346	ME-6757A.....	99, 111
CI-6532A.....	40	EM-8675.....	213	EX-5505A.....	308	EX-9987.....	347	ME-6798.....	126
CI-6537.....	28	EM-8678A.....	210	EX-5506.....	309	EX-9988.....	349	ME-6800.....	124
CI-6538.....	25-27	EM-8679.....	211	EX-5508.....	310	EZ-2331.....	75	ME-6802.....	124
CI-6556.....	50	EM-8784.....	217	EX-5509A.....	311	EZ-2333A.....	75	ME-6810A.....	37, 39,
CI-6604.....	48	EM-8785.....	217	EX-5510B.....	312	EZ-2334.....	75	.....	126, 129
CI-6605A.....	44	EM-8812.....	215	EX-5511A.....	313	EZ-2337.....	75	ME-6816.....	173
CI-6620.....	66	EM-8813.....	215	EX-5512.....	315	EZ-2338.....	75	ME-6819A.....	185
CI-6688.....	25	EM-8814.....	218	EX-5513A.....	316	EZ-2339.....	75	ME-6821A.....	129
CI-6689A.....	26, 167	EM-8815.....	218	EX-5516A.....	319	EZ-2340.....	75	ME-6822.....	129, 183
CI-6690.....	169	EM-8817.....	223	EX-5517A.....	321	EZ-2341.....	75	ME-6824.....	125
CI-6691.....	25, 165	EM-9740.....	216	EX-5518A.....	320	ME-1234.....	116, 157, 188	ME-6825A.....	125
CI-6692.....	26, 112	EM-9745.....	216	EX-5519A.....	322	ME-1235.....	157, 188	ME-6828.....	109
CI-6742A.....	24	EP-3563.....	90, 136, 252	EX-5520A.....	323	ME-1240.....	94, 98	ME-6829.....	26, 131
EM-3534.....	208-209	EP-3567.....	87	EX-5522A.....	324	ME-1241.....	94, 98	ME-6830.....	130
EM-3535.....	208-209	EP-3571.....	87	EX-5523A.....	325	ME-1242.....	103	ME-6831.....	130
EM-3536.....	208-209	EP-3572.....	89, 90	EX-5524A.....	326	ME-1243.....	99	ME-6837.....	170
EM-6711.....	227	EP-6323.....	87	EX-5525.....	327	ME-2220.....	41, 70	ME-6838A.....	37, 137, 180
EM-6712.....	227	EP-6323-EBK.....	87	EX-5527.....	328	ME-2221.....	41, 70	ME-6841.....	100
EM-6713.....	227	EP-6471.....	88	EX-5529A.....	329	ME-2224.....	41, 173	ME-6842.....	155
EM-6714.....	227	EP-6472.....	88	EX-5530A.....	330	ME-5701.....	93	ME-6843.....	106
EM-6715.....	227	EP-6477.....	90, 136	EX-5531.....	331	ME-5702.....	93	ME-6844.....	155
EM-6722.....	227	EP-6478.....	90, 271	EX-5532.....	332	ME-5703.....	93	ME-6847.....	106
EM-6723.....	227	EP-6479.....	90, 252	EX-5533.....	335	ME-5704.....	93	ME-6853.....	127
EM-6724.....	227	EP-6480.....	90, 252	EX-5534.....	336	ME-5705.....	93	ME-6855.....	134, 181
EM-8099.....	225	EP-6481.....	90, 271	EX-5535.....	337	ME-5706.....	93	ME-6856.....	170
EM-8618.....	225	EP-6483.....	90, 136	EX-5536.....	338	ME-5707.....	93	ME-6933.....	99
EM-8620.....	230	EP-6485.....	88	EX-5537.....	339	ME-5708.....	93	ME-6934.....	99
EM-8622.....	213	EP-6490.....	87	EX-5538.....	340	ME-5709.....	93	ME-6937.....	65
EM-8624A.....	214	ES-9042A.....	207	EX-5539A.....	341	ME-5710.....	93	ME-6957.....	111
EM-8627.....	213, 214, 218	ES-9056.....	207	EX-5540A.....	343	ME-5711.....	93	ME-6960.....	99-100
EM-8628.....	214	ES-9057C.....	207	EX-5541A.....	344	ME-5712.....	93	ME-6972.....	170
EM-8630.....	214, 218	ES-9059C.....	207	EX-5542.....	345	ME-5713.....	93	ME-6974.....	147
EM-8631A.....	214, 230	ES-9060.....	205	EX-5543A.....	350	ME-5714.....	93	ME-6977.....	102
EM-8632.....	214, 217	ES-9061.....	207	EX-5544A.....	351	ME-5715.....	93	ME-6978.....	189, 244

ME-6982..... 189, 244	ME-8244..... 148-149	ME-8985..... 187	ME-9781..... 102	OS-8469..... 265
ME-6983..... 146	ME-8245..... 153	ME-8986..... 111, 119, 184	ME-9803B..... 111	OS-8470..... 256
ME-6984..... 146	ME-8246..... 153	ME-8987..... 154	ME-9804..... 38, 97	OS-8471A..... 270
ME-6985..... 147	ME-8247..... 152	ME-8988..... 176	ME-9805..... 37	OS-8472..... 270
ME-6986..... 147	ME-8248..... 152	ME-8995..... 179	ME-9806..... 97	OS-8473..... 263
ME-6987..... 147	ME-8249..... 153	ME-8998..... 24, 112	ME-9807..... 107	OS-8474..... 257
ME-6988A..... 31, 33, 147	ME-8270..... 177	ME-8999..... 111, 156	ME-9812..... 120	OS-8476..... 264
ME-6990..... 141	ME-8569..... 175, 193	ME-9204B..... 37, 113	ME-9813..... 120	OS-8477A..... 264-265
ME-6991..... 142	ME-8574..... 107	ME-9207B..... 39, 123	ME-9814..... 120, 147	OS-8479..... 259
ME-6992B..... 143	ME-8594..... 185	ME-9215B..... 113	ME-9815..... 120	OS-8494..... 258, 265
ME-6993..... 147	ME-8734..... 121	ME-9239..... 119	ME-9821..... 26, 163	OS-8495..... 260
ME-6994..... 147	ME-8735..... 176	ME-9283..... 116	ME-9823..... 112	OS-8496..... 260
ME-6995..... 147	ME-8736..... 176	ME-9284..... 116	ME-9825A..... 154	OS-8501..... 282
ME-6996..... 147	ME-8738..... 176	ME-9337..... 187	ME-9833..... 166	OS-8502..... 282
ME-6997..... 147	ME-8741..... 176	ME-9350..... 187	ME-9836..... 112	OS-8508..... 259
ME-6998A..... 33, 147	ME-8743..... 179	ME-9351..... 187	ME-9837A..... 163	OS-8510..... 259
ME-6999A..... 147	ME-8744..... 179	ME-9355..... 177	ME-9838..... 117	OS-8514..... 279
ME-7001..... 145	ME-8750..... 110	ME-9376B..... 179	ME-9847..... 164	OS-8515C..... 254-255
ME-7002..... 147	ME-8752..... 37, 157	ME-9377A..... 38	ME-9859..... 128	OS-8516A..... 256
ME-7003..... 144	ME-8930..... 114-115	ME-9403A..... 113	ME-9864..... 129, 183	OS-8519..... 258
ME-7008..... 147	ME-8932..... 115	ME-9426A..... 121	ME-9865A..... 129	OS-8522..... 257
ME-7009..... 146	ME-8933..... 38, 97	ME-9430..... 99	ME-9866..... 156	OS-8524..... 257
ME-7011..... 147	ME-8949..... 132	ME-9447B..... 133	ME-9868A..... 129	OS-8525A..... 269, 279
ME-7012..... 147	ME-8950A..... 158-159	ME-9448B..... 111, 137, 180	ME-9872..... 129, 183	OS-8531A..... 267
ME-7017..... 147	ME-8951..... 160	ME-9450A..... 137, 180	ME-9873..... 179	OS-8533A..... 27, 262
ME-7559..... 185	ME-8952..... 160	ME-9454..... 99	ME-9875..... 184	OS-8534A..... 269
ME-7566..... 187	ME-8953..... 160	ME-9471A..... 38, 97	ME-9876..... 184	OS-8535A..... 27, 269
ME-7586..... 175	ME-8954..... 176	ME-9472..... 179	ME-9884..... 30, 108	OS-8537..... 274-275
ME-7589..... 187	ME-8955..... 161	ME-9483..... 137, 177, 180	ME-9885A..... 30, 108	OS-8539..... 26, 274-275
ME-7590..... 187	ME-8960..... 27, 168-169	ME-9486..... 104	ME-9889..... 122	OS-8541..... 259
ME-8088..... 162	ME-8961..... 168	ME-9493..... 99	ME-9890..... 183	OS-8542..... 276
ME-8094..... 162	ME-8963..... 169	ME-9495A..... 112	ME-9892..... 26, 131	OS-8543..... 276
ME-8229..... 152	ME-8966A..... 171	ME-9498A..... 37	MG-8600..... 229	OS-8544..... 276
ME-8231..... 150	ME-8968..... 129, 164, 183	ME-9499..... 137, 180	OS-8170A..... 263	OS-8549..... 263
ME-8232..... 150	ME-8969..... 165	ME-9502..... 135	OS-8171..... 263	OS-9107..... 293
ME-8233..... 150	ME-8970..... 155	ME-9503..... 135	OS-8172..... 62, 261	OS-9172..... 279
ME-8234..... 150	ME-8971..... 112	ME-9504..... 135	OS-8450..... 274-275	OS-9255A..... 283
ME-8235..... 150	ME-8972..... 112	ME-9506..... 156-157, 178	OS-8452..... 266	OS-9256A..... 283
ME-8236..... 150	ME-8976..... 176	ME-9507..... 178	OS-8453..... 268	OS-9258B..... 283
ME-8237..... 153	ME-8977..... 176	ME-9509..... 181	OS-8456..... 258	OS-9261B..... 293
ME-8238..... 153	ME-8978A..... 177	ME-9510..... 181	OS-8457..... 256	OS-9263B..... 293
ME-8239..... 152	ME-8979..... 187	ME-9511..... 181	OS-8458A..... 269, 279	OS-9477A..... 62, 261
ME-8240..... 152	ME-8981..... 187	ME-9512..... 181	OS-8460..... 259	PI-8117..... 39
ME-8241..... 152	ME-8982..... 187	ME-9513..... 181	OS-8465..... 256	PI-8127..... 238
ME-8242..... 152	ME-8983..... 187	ME-9774..... 164	OS-8466A..... 258	PI-9880..... 231
ME-8243..... 150	ME-8984..... 187	ME-9779..... 99	OS-8468..... 265	PK-9023..... 205

## Part Number Index

PK-9025B.....	205	PS-2187.....	68	PS-3203.....	43	SE-7231.....	204	SE-8691.....	204
PK-9026.....	205	PS-2189.....	29	PS-3204.....	59	SE-7232.....	204	SE-8693.....	126, 129, 184
PK-9031B.....	205	PS-2193.....	53	PS-3206.....	67	SE-7233.....	204	SE-8695.....	182
PS-2011.....	10, 11, 16	PS-2194.....	64	PS-3207.....	66	SE-7235A.....	285	SE-8703A.....	186
PS-2103A.....	24	PS-2195.....	70	PS-3208.....	63	SE-7256.....	24	SE-8704A.....	186
PS-2107.....	40	PS-2196.....	64	PS-3209.....	72	SE-7260.....	290	SE-8707.....	186
PS-2111.....	66	PS-2197.....	46, 201	PS-3210.....	74	SE-7285.....	129, 179	SE-8708.....	186
PS-2112.....	54	PS-2198.....	32	PS-3211.....	52, 208-209	SE-7287.....	175, 185	SE-8710.....	182
PS-2114.....	43	PS-2199.....	32, 140	PS-3212.....	52	SE-7288.....	175, 185	SE-8712A.....	182
PS-2115.....	53	PS-2200.....	33	PS-3213.....	48	SE-7289.....	175, 185	SE-8723.....	186
PS-2117.....	58	PS-2201.....	33	PS-3215.....	60, 74	SE-7317.....	192	SE-8725.....	186
PS-2120A.....	25-27	PS-2204.....	33	PS-3401.....	58, 191	SE-7319.....	246	SE-8726A.....	186
PS-2125.....	44	PS-2205.....	32	PS-3500.....	17, 22	SE-7331.....	156, 251	SE-8728.....	129, 184
PS-2126A.....	63	PS-2206.....	32	PS-3501.....	16	SE-7335B.....	117	SE-8729.....	184
PS-2128.....	34, 105	PS-2207.....	65	PS-3514.....	59	SE-7337.....	182	SE-8749.....	155
PS-2130.....	69	PS-2222.....	41, 69	PS-3515.....	59	SE-7342.....	253	SE-8756B.....	186
PS-2131.....	45	PS-2225.....	41, 69, 173	PS-3516.....	59	SE-7345.....	253	SE-8757B.....	186
PS-2132.....	56, 206	PS-2226.....	41, 69	PS-3517.....	59	SE-7347.....	184	SE-8758B.....	186
PS-2134.....	46	PS-2234.....	62	PS-3518.....	59	SE-7355.....	204	SE-8759.....	187
PS-2135.....	45	PS-2235.....	62	PS-3519.....	59	SE-7370.....	171	SE-8760.....	156, 251
PS-2136A.....	35	PS-2343.....	151, 285	PS-3520.....	59	SE-7390.....	229	SE-8768.....	188
PS-2137.....	16, 67, 139	PS-2400.....	21	PS-3521.....	59	SE-7560.....	185	SE-8777.....	60
PS-2138.....	67, 139	PS-2401.....	21	PS-3544.....	217	SE-7571.....	183	SE-8792.....	241
PS-2139.....	67	PS-2500.....	22	PS-3553.....	73	SE-7573.....	280	SE-8799.....	218
PS-2140.....	57	PS-2521B.....	64	PS-3701.....	36, 137	SE-7574.....	280	SE-8805A.....	279
PS-2141.....	31, 139	PS-2522.....	68	PS-3702.....	36, 137, 180	SE-7581.....	258	SE-8806.....	117
PS-2142.....	31, 139	PS-2546.....	24	SA-9241.....	137, 180	SE-7585.....	226	SE-8821.....	186
PS-2143.....	45	PS-2547.....	139	SA-9242.....	137, 177, 180	SE-7586.....	175	SE-8822.....	186
PS-2146.....	42	PS-2548.....	31, 139	SB-9549A.....	237	SE-7940.....	299	SE-8823A.....	186
PS-2148.....	49	PS-2565.....	58	SB-9621A.....	240	SE-7943.....	299	SE-8827.....	182
PS-2150.....	49	PS-2567.....	68	SB-9631B.....	241	SE-7945.....	299	SE-8828.....	232
PS-2151.....	69	PS-2568.....	68	SB-9632.....	241	SE-8028A.....	123	SE-8837.....	219
PS-2152.....	68	PS-2577.....	15	SE-3570.....	103	SE-8050.....	111, 184	SE-9013.....	257
PS-2153.....	45	PS-2587.....	64	SE-6597.....	278	SE-8505A.....	279	SE-9021A.....	280
PS-2155.....	46	PS-2588.....	64	SE-6608.....	278	SE-8506.....	280	SE-9022A.....	280
PS-2158.....	39	PS-2600.....	21, 62, 272-273	SE-6609.....	288	SE-8509.....	276	SE-9072.....	123
PS-2159.....	39	PS-2601.....	62, 272	SE-6612.....	288	SE-8568.....	175	SE-9084B.....	201
PS-2160.....	54	PS-2611.....	67	SE-6614.....	288	SE-8587.....	233	SE-9358.....	275
PS-2162.....	55	PS-2815.....	81	SE-6615.....	236, 288	SE-8603.....	229	SE-9372.....	179
PS-2163.....	73	PS-2833.....	81	SE-6621.....	236, 288	SE-8604.....	230	SE-9373.....	179
PS-2164.....	42	PS-2848.....	80	SE-6655.....	163	SE-8626.....	217	SE-9409.....	184, 251
PS-2168.....	56	PS-2849.....	82	SE-6849.....	193	SE-8636A.....	200	SE-9415A.....	216
PS-2176.....	49	PS-2863.....	83	SE-7123.....	216	SE-8645.....	224	SE-9444.....	178
PS-2179.....	75	PS-2868.....	83	SE-7124.....	239	SE-8653A.....	226	SE-9445.....	178
PS-2180.....	36, 96, 157	PS-3200.....	10, 11, 16	SE-7125.....	250	SE-8680.....	230	SE-9446.....	178
PS-2181.....	41, 173	PS-3201.....	46	SE-7128A.....	201, 281, 285	SE-8689.....	239	SE-9449.....	279
PS-2184.....	51	PS-3202.....	29, 34	SE-7226.....	175	SE-8690.....	184, 251	SE-9460.....	278

SE-9461.....	278	SF-7579.....	230, 290	SN-9795.....	299	WA-9495.....	248
SE-9462.....	278	SF-8607.....	228	SN-9796.....	299	WA-9594.....	249
SE-9463.....	278	SF-8608.....	228	SN-9797.....	299	WA-9605.....	249
SE-9464.....	278	SF-8609.....	226	SP-9268A.....	277	WA-9606.....	249
SE-9465.....	278	SF-8610.....	226	TD-8498A.....	195	WA-9607.....	246
SE-9466.....	278	SF-8611.....	226	TD-8550A.....	200	WA-9800A.....	284
SE-9467.....	278	SF-8612.....	226	TD-8551A.....	194	WA-9801.....	284
SE-9468.....	278	SF-8613.....	226	TD-8553.....	202	WA-9802.....	284
SE-9600.....	250	SF-8616.....	226	TD-8554A.....	202	WA-9826.....	253
SE-9601.....	250	SF-8617.....	226	TD-8555.....	202	WA-9857A.....	244
SE-9622.....	236	SF-8619.....	229	TD-8556.....	191	WA-9867.....	245
SE-9626.....	287	SF-8711.....	182	TD-8557B.....	193	WA-9896.....	243
SE-9629.....	287	SF-9068.....	207	TD-8561.....	192	WA-9897.....	243
SE-9639.....	289	SF-9069.....	207	TD-8570A.....	202	WA-9898.....	243
SE-9644.....	236	SF-9214.....	118	TD-8572A.....	27, 198-199	WA-9899.....	242-243
SE-9645.....	289	SF-9216.....	118-119	TD-8577.....	195	WA-9900.....	248
SE-9650.....	289	SF-9217.....	119	TD-8581A.....	199		
SE-9651.....	287	SF-9224.....	119	TD-8582.....	194		
SE-9654.....	291	SF-9295.....	119	TD-8583.....	194		
SE-9655.....	291	SF-9298.....	119	TD-8595.....	197		
SE-9656.....	291	SF-9322.....	246, 247	TD-8596A.....	196		
SE-9716C.....	279	SF-9323.....	246, 247	TD-8825A.....	193		
SE-9717A.....	171	SF-9324.....	246	TD-8855.....	203		
SE-9719A.....	175	SF-9404.....	247	TD-8856.....	190		
SE-9720A.....	232	SF-9405.....	247	UI-5000.....	10, 11, 12-13		
SE-9721A.....	233	SF-9500A.....	239	UI-5001.....	10-11, 14		
SE-9750.....	216	SF-9568A.....	239	UI-5100.....	51		
SE-9751.....	216	SF-9569A.....	239	UI-5110.....	51		
SE-9756.....	217	SF-9580.....	237	UI-5119.....	13		
SE-9758.....	217	SF-9581.....	235	UI-5129.....	13		
SE-9786A.....	241	SF-9584B.....	235	UI-5210.....	13		
SE-9788.....	123	SF-9585A.....	234	UI-5218.....	13, 22		
SE-9790.....	171	SF-9586B.....	234	UI-5400.....	18-20		
SF-6300.....	119	SN-7900A.....	296	UI-5401.....	18-20		
SF-6301.....	119	SN-7901B.....	297	UI-5405.....	18-20		
SF-6302.....	119	SN-7902.....	298	UI-5406.....	18-20		
SF-6303.....	119	SN-7927A.....	39, 61, 298	UI-5800B.....	76		
SF-6304.....	119	SN-7941.....	299	UI-5801B.....	76		
SF-6305.....	119	SN-7942.....	299	UI-5802.....	77		
SF-6306.....	119	SN-7949A.....	299	UI-5803.....	77		
SF-6307.....	119	SN-7970A.....	299	UI-5813.....	78		
SF-6308.....	119	SN-7972A.....	299	UI-5820.....	79		
SF-6309.....	119	SN-7995A.....	296, 299	WA-9314C.....	284		
SF-6310.....	119	SN-8110.....	299	WA-9315.....	284		
SF-6311.....	119	SN-8111A.....	299	WA-9316A.....	284		
SF-6312.....	119	SN-9085.....	299	WA-9319A.....	284		
SF-6313.....	119	SN-9794.....	299	WA-9401.....	156, 246		

## Product and Topic

1-Axis Force Platform..... 31, 139	— A —	Advanced Physics Lab Bundles..... 81, 83
10-32 Adapter ..... 153	A-base Adapter for Rotary Motion ..... 169	Advanced Physics Lab Manual, High School ..... 80, 82
10-port USB Charging Station ..... 16	A-base Rod Stand ..... 176	Advanced Structures Set ..... 143
18 VDC, 3A Power Supply ..... 232	Aberration, Spherical – See Aperture Access. .... 257	Advanced Water Quality..... 7
18 VDC, 5A Power Supply ..... 232	Absolute Pressure Sensor..... 40	Air Cannon ..... 171
2-Axis Magnetic Field Sensor ..... 55	Absolute Pressure/Temperature Sensor ..... 42	Air Core Solenoid..... 226
2-Axis Force Platform..... 31, 139	Absolute Zero Apparatus..... 197	Air Column, Resonance..... 249
2-meter Patch Cord ..... 216	Absorbers, Radiation ..... 299	Air Friction Coin and Feather..... 123
3-Axis Acceleration Altimeter Sensor ..... 35	AC/DC Electronics Lab Electronic Components ..... 212	Air Pressure Demo ..... 171
3-Axis Gyroscope ..... 27, 168-169	AC/DC Electronics Laboratory ..... 212	Air Pressure Sensor ..... 43, 72
3-D Magnetic Field Demonstrator ..... 229	AC/DC Power Supply..... 235	Air Source, Cordless ..... 117
3-Point Bending..... 153	Acceleration Altimeter Sensor, PASPORT 3-Axis..... 35	Air Supply, Variable Output ..... 119
30 VDC, 6A Power Supply ..... 233	Acceleration – Freefall ..... 122-123	Air Track and Accessories..... 118-119
4-Point Bending..... 153	Acceleration Sensor ..... 34-35	Air Velocity – See Pitot Tube ..... 41, 69
5 N Load Cell ..... 33	Accelerometer Springs ..... 121	AirLink, Wireless..... 10-11, 16
6-in-1 Weather..... 7	Accelerometer, Amusement Park ..... 121	Alligator Clip Adapters ..... 217
8-Pin DIN Extender Cable ..... 13, 22	Accelerometer, Visual ..... 34, 105	Alligator Clip Leads..... 218
50 mm Diameter Lens Assortment..... 258	Accessory Photogate ..... 37, 113	Alligator Test Leads, Shrouded..... 217
60 cm Optics Bench ..... 259	Acid Base – See pH Sensor..... 59	Alignment Bench, Laser..... 279
100 MHz Digital Storage Oscilloscope ..... 240	Acoustic Resonance– see Resonance Tube ..... 248-249	Alnico Magnets..... 230
100 N Load Cell ..... 33, 140	Acoustics, Sound Sensor ..... 57	Alpha Sources..... 299
100 NTU Calibration Standard ..... 73	Actuator, Wave Motion ..... 250	Altimeter/3-Axis Accelerometer ..... 35
120 cm Optics Bench ..... 259	Adapter, Freefall Timer ..... 39, 123	Altitude..... 35
200 -3200 Turn Coils ..... 226	Adapters, Ohaus Balances..... 186	Aluminum Cart ..... 99
550 Universal Interface..... 10-11, 14	ScienceWorkshop-to-PASPORT ..... 39	Aluminum Table Clamp..... 179
850 Physics Probeware Bundles..... 76-77	USB Bluetooth 4.0..... 17, 22	Aluminum Tracks..... 99
850 Accessories..... 13	Adiabatic Compression Fire Syringe ..... 195	Ammeter, Analog ..... 239
850 Comprehensive System Electromagnetism ..... 77	Adiabatic Gas Law Apparatus..... 195	Amplifier, DC Current..... 236
Experiment Manual..... 78	Adjustable Angle Clamp ..... 179	Amplifier, Dual Load Cell ..... 32
Mechanics..... 76, 79	Adjustable End Stops..... 112	Amplifier Set with Load Cell ..... 32, 140
Optics ..... 77	Adjustable Feet..... 112	Amusement Park Physics..... 121
Physics..... 76	Adjustable Lens ..... 258, 265	Analog Adapter, ScienceWorkshop-to-PASPORT ..... 39
Thermodynamics ..... 77	Adjustable Lens Holder..... 257	Anemometer..... 72
Waves..... 77	Adjustable Speed Motorized Cart ..... 102	See Weather Sensor..... 72
850 Experiment Manual..... 78	Advanced Nuclear Spectroscopy System..... 297	Angle Indicator (Dynamics Track) ..... 112
850 Function Generator BNC Cables ..... 13		Angle Sensor– See Human Arm ..... 67
850 Physics Probeware Bundles..... 76-79		Angular Momentum Experiment, Conservation of ..... 321
850 Universal Interface..... 10-12		Aperture Accessories (Basic Optics) ... 257
		Aperture Bracket, Light Sensor ..... 269

- App, MatchGraph..... 21  
 App, SPARKvue..... 21  
 App, Spectrometry..... 21, 273  
 Aquatics Productivity Bottles..... 65  
 Archimedes' Principle  
   Experiment..... 318  
 Argon Tube, Franck-Hertz..... 289  
 Arm Model,  
   PASPORT Human..... 68, 138  
 Atmospheric Pressure  
   Demonstrator..... 171  
 Atmospheric Pressure Sensor..... 43, 72  
 Atomic Spectra Experiment..... 354  
 Atwood's Machine..... 137, 180  
 Atwood's Machine Experiment..... 304  
 Avogadro—See Mole Set..... 175
- B —
- Balance, Current..... 228  
 Balance, Equal Arm..... 132  
 Balances, Electronic..... 186  
 Ball Launchers..... 124-128  
 Ballistic Cart Accessory..... 104  
 Ballistic Pendulum..... 130  
 Ballistic Pendulum Accessory..... 26, 131  
 Ballistic Pendulum Experiment..... 313  
 Balls..... 129, 183  
 Balls, Gravitational Torsion..... 292  
 Banana Plugs..... 216  
 Banana Plugs, Shrouded..... 216  
 Banana-to-Alligator Clip Adapters..... 217  
 Bar Magnets..... 230  
 Barium-133..... 299  
 Barium-137m..... 299  
 Barometer/Low Pressure..... 7  
 Base, Large Rod..... 176  
 Base, Small "A"..... 176  
 Base, Small Round w/ rod..... 177  
 Base, Support Rod..... 177  
 Basic Calorimetry Set..... 193  
 Basic Current Balance..... 228  
 Basic Digital Multimeter..... 241  
 Basic Electricity Lab..... 213  
 Basic Optics Spares Kit..... 259  
 Basic Optics System..... 254-255
- Basic Optics  
   Concave/Convex Mirror..... 256  
   Color Mixer..... 260  
   Diode Laser..... 269, 279  
   Light Source..... 256  
   Slit Accessories..... 268  
   Storage Box..... 255  
   System..... 254-255  
 Basic Optics Viewing Screen..... 259  
 Basic Variable Capacitor..... 207  
 Batteries, Rechargeable..... 103  
 Battery Charger..... 103  
 Battery Holders..... 218  
 Beakers..... 175, 185  
 Beam Bending..... 153  
 Beams..... 147  
 Bell Jar, Student..... 171  
 Bench, Optics..... 259  
 Bending Accessory..... 153  
 Beta Sources..... 299  
 Bicycle Gyro..... 170  
 Biomechanics..... 16, 31, 67, 138-139, 145  
 Blackbody Experiment..... 329  
 Blackbody Light Source..... 276  
 Blackbody Radiation Experiment..... 329  
 Blood Pressure Sensor..... 65  
 Black Thread..... 184  
 Blower, Air..... 117  
 Bluetooth, USB Adapter..... 17, 22  
 BNC 850 Function Generator  
   Cables..... 13  
 Bohr Magnetron..... 291  
 Bottles, Aquatic Productivity..... 65  
 Bounce/No Bounce Ball Set..... 183  
 Brachistochrone—  
   See Roller Coaster..... 120-121  
 Brackets  
   Collisions (Force)..... 30, 108  
   Eye Model..... 265  
   Force..... 30, 108  
   Gyroscope Mount..... 169  
   Magnetic, Motion Sensor..... 24  
   Parallel Spring..... 155  
   Photogate..... 97  
   Structures for.....  
   Force Platform..... 31, 33, 147
- Braided Physics String..... 111, 184  
 Breath Rate Sensor..... 68  
 Breathing Sensor—  
   See Respiration..... 68  
 Breathing Sensor—  
   See Spirometer..... 68  
 Brewster's Angle Accessory..... 263  
 Brewster's Angle Experiment..... 349  
 Bridge Deflection  
   see Displacement Sensor..... 33  
 Bridge Set, Structures..... 142  
 Bridge Shaking..... 356-357  
 Bridge Vibrations  
   Experiment..... 356-357  
 Broad Spectrum Light Sensor..... 48  
 Buggy, Constant Speed..... 123  
 Bulbs, Replacement for  
   Series/Parallel Circuit..... 218  
 Bumper Accessory Set..... 30, 108  
 Bumper Set, Magnetic..... 30, 108  
 Bumper, Elastic..... 24, 112  
 Bundles  
   Comprehensive 850..... 76-77  
   Essential Physics..... 87  
   Inquiry-based Physics..... 81, 83  
   Mechanics 850..... 79  
   STEM Modules..... 88-90  
 Buoyancy..... 175, 318  
 Buoyant Force —  
   See Density Set..... 175, 318  
 Buret Clamp..... 178
- C —
- "C" Clamps..... 179  
 Cable, 8-pin DIN Sensor  
   Extender..... 13, 22  
 Cable, Fiber Optic  
   (Spectrometer)..... 62, 272  
 Cable,  
   PASPORT Sensor Extension..... 22  
   Phone Jack Extender..... 39  
 Cadmium-109..... 299  
 Calibrated Polarizer..... 263  
 Calibration Standard, 100 NTU..... 73  
 Calipers, Digital..... 182  
 Caliper, Optics..... 265  
 Calipers, Vernier..... 182

## Product and Topic

- Calorimeter Cup ..... 193  
 Calorimeter, Energy Transfer ..... 194  
 Calorimetry Set ..... 193  
 Cameras ..... 285  
 Can, Overflow ..... 175  
 Cannon, Air ..... 171  
 Cans, Radiation ..... 202  
 Capacitance Experiment ..... 335  
 Capacitor Assortment ..... 217  
 Capacitor Box, Decade ..... 239  
 Capacitor Circuit ..... 210-211  
 Capacitor, 1 Farad ..... 217  
 Capacitor, Basic Variable ..... 207  
 Capacitor, CASTLE Kit ..... 214  
 Capacitor, Variable ..... 207  
 Capacitors ..... 217  
 Capstone Experiment List ..... 303  
 Capstone Software,  
   See PASCO Capstone ..... 18-20  
 Carbon Dioxide Sensor,  
   PASPORT ..... 7  
 Carbon Dioxide Sensor,  
   Wireless ..... 63  
 Carbon Paper ..... 126, 129, 184  
 Carriage, Dynamics Track Optics ..... 270  
 Cart Adapter Accessory,  
   Motion Sensor ..... 24, 108  
 Cart Launcher, Spring ..... 106  
 Carts and Accessories  
   Accelerometer, Visual ..... 34, 105  
   Angle Indicator ..... 112  
   Adjustable-Speed Cart ..... 102  
   Ballistic Cart Accessory ..... 104  
   Bumper Accessory Kit ..... 30, 108  
   Cart Adapter Accessory ..... 24, 108  
   Cart Damping Accessory,  
     Magnetic ..... 109  
   Classic Carts ..... 92, 99  
   Collision Cart ..... 92, 99  
   Compact Cart Mass ..... 111  
   Constant Velocity Cart ..... 123  
   Constant-Force Cart ..... 102  
   Dynamics Cart Tracks ..... 92, 99-101  
   Dynamics Track  
     Spring Set ..... 111, 156  
   Elastic Bumper ..... 24, 112  
   End Stops, Adjustable ..... 112  
   Fan Accessory, Smart ..... 103  
   Fan Cart ..... 102  
   Feet, Adjustable ..... 112  
   Friction Accessory, Discover ..... 107  
   Friction Block ..... 107  
   Friction Cart Accessory ..... 107  
   Magnetic Bumper Set ..... 30, 108  
   Mass Bar ..... 99, 111  
   Measurement Systems ..... 113-116  
   Mechanical Oscillator/Driver ..... 110  
   Motion Sensor ..... 24  
   Motorized Cart ..... 102  
   PAScars ..... 92, 99  
   PAScar Mass ..... 99, 111  
   Plunger Cart ..... 92, 99  
   Replacement Axles ..... 111  
   Rubber Cord ..... 111, 119, 184  
   Smart Carts ..... 92, 94, 98  
   Spring Cart Launcher ..... 106  
   Spring Set ..... 111, 156  
   Super Pulley with Clamp ..... 111, 137, 180  
   Time Pulse Accessories ..... 103  
   Timing Options ... 94-95, 96-97, 113-116  
   Tracks ..... 92, 99-101  
   Wheels, Replacement ..... 111  
 Carts and Tracks ..... 92-112  
 Carts ..... 92, 98-99  
 Cast Beams ..... 146  
 CASTLE Curriculum Guide ..... 214  
 CASTLE Kit ..... 214  
 Cavendish Balance ..... 291  
 Cavendish Experiment ..... 317  
 Cellular Respiration ..... 63  
 Cent-O-Gram Balance ..... 186  
 Centripetal Motion & Force  
   Accessory (Computer Based) ..... 162  
   Accessory (Rotating Platform) ..... 160  
   Accessory, Wireless ..... 162  
   Apparatus ..... 162  
   Discover (Hand-Held) Kit ..... 163  
   Experiments ..... 308-309  
   Flying Pig ..... 163  
   Pendulum ..... 26, 163  
 Chair, Rotating ..... 170  
 Chaos Experiment ..... 323  
 Chaos/Driven Harmonic  
   Accessory ..... 26, 167  
 Charge – See Electrometer ..... 206  
 Charge, Equipotential and  
   Field Mapper ..... 205  
 Charge Experiment ..... 332  
 Charge/Discharge Circuit ..... 210  
 Charge of an Electron  
   Experiment ..... 334  
 Charge Producers and  
   Proof Plane ..... 207  
 Charge Sensor ..... 56, 206  
 Charge-to-Mass Ratio ..... 287  
 Charging Garage, Smart Cart ..... 98  
 Charging Station,  
   10-port ..... 16  
   Smart Cart ..... 98  
   SPARKlink Air ..... 16  
 Chemistry & Advanced Chemistry  
   Sensors ..... 7  
 Chladni Plates Kit ..... 246  
 Chladni Violin Plate ..... 246  
 Circuit Components ..... 217-218  
 Circuit, Charge/Discharge ..... 210  
 Circuit Laws,  
   Kirchhoff's Experiment ..... 340  
 Circuit,  
   Resistor-Capacitor-Inductor ..... 13, 210  
 Circuit, RLC ..... 211  
 Circuits ..... 208-218  
 Circuits, Modular ..... 208-209  
 Circulation, Density ..... 173  
 Circular Motion  
   Centripetal Force ..... 160, 162-163  
 Complete Rotational System ..... 158-159  
   Rotary Motion Sensor ..... 25-27  
 Clamp, Pivot ..... 112  
 Clamps ..... 178-179  
 Classroom Density Set ..... 175  
 Clevis Grip ..... 153  
 Cloud Chamber ..... 300-301  
 CO<sub>2</sub> Gas Sensor, Wireless ..... 63  
 Cobalt ..... 299

Coils	Nuclear Systems ..... 296-297	Electron Charge-to-Mass ..... 287
Air Core Solenoid ..... 226	PASCO Capstone Software ..... 18-20	Newton's Gravitational Constant ..... 292
Coils and Cores Set ..... 226	Sensors ..... 22-75	Permittivity of Free Space ..... 293
Detector Coils ..... 227	SPARKlink Air ..... 10-11, 16	Planck's Constant ..... 288
Field Coils ..... 227	Computer Software ..... 18-21	Speed of Light ..... 294-295
Helmholtz ..... 227	Computer-Based	Container Set, 3.8 Liter Plastic ..... 185
LED Indicator ..... 227	Centripetal Force ..... 162	Construction
Primary and Secondary ..... 226	Computer-Based	See Structures ..... 140-147
Coin and Feather Tube ..... 123	Diffraction System ..... 266	Convex Mirror,
Collision Cart ..... 99	Computer-Based Gravitational	Demonstration Size ..... 280
Color Addition ..... 260	Torsion Balance ..... 292	Convex/Concave Mirror ..... 280
Color Filter Set	Concave/Convex Mirror	Cord, Elastic Wave ..... 184, 251
(for Color Mixer) ..... 260	Accessory ..... 256	Cord, Rubber ..... 111, 119, 184
Colorimeter, PASPORT ..... 7	Concave Mirror,	Cord, Yellow ..... 184
Colorimeter, Wireless	Demonstration Size ..... 280	Cordless Air Source ..... 117
w/Turbidity ..... 74	Conduction, Thermal ..... 192	Cords, Patch ..... 216
Colorimeter, Water Quality ..... 75	Conductive Ink Pen ..... 205	Cores, Solenoid and Coil ..... 226
Color Mixer ..... 260	Conductive Paper ..... 205	Coulomb's Law Apparatus ..... 293
Color Mixer Accessory Kit ..... 260	Conductive Shapes ..... 207	Coulomb's Law Experiment ..... 333
Column Buckling ..... 152	Conductive Spheres ..... 207	Counter, Radiation ..... 298
Compact Cart Mass ..... 111	Conductivity Probe ..... 7	Current Balance ..... 228
Compact Speed of Light ..... 294	Conductivity Sensor, PASPORT ..... 7	Current Balance Accessory Kit ..... 228
Compact Thermal Expansion ..... 190	Conductivity Sensor, Wireless ..... 75	Current, PASPORT High ..... 53
Compass, Liquid Filled ..... 230	Conductivity, Thermal ..... 192	Current Probe ..... 51
Compass, Plotting ..... 230	Conservation of	Current Sensor ..... 50-53
Complete e/m System ..... 287	Momentum Experiment ..... 312	Current Sensor, Modular ..... 208-209
Complete Interferometer System ..... 283	Conservation of Angular	Current Sensor, Wireless ..... 52
Complete Roller Coaster ..... 120	Momentum Experiment ..... 321	Curriculum, Physics ..... 84-91
Complete Rotational System ..... 158-159	Conservation of Energy	Curriculum, STEM ..... 88-90
Complete Wave Motion	Experiments ..... 314-315	Curved PAStack ..... 100-101
Demonstrator ..... 250	Conservation of Momentum	Curved Track/Smart Cart Dynamics
Components,	Experiment ..... 312	System ..... 101
Spectrophotometer ..... 275	Constant Acceleration,	Cuvettes and Caps,
Component Testers ..... 241	see Visual Accelerometer ..... 34, 105	Colorimeter ..... 60-61, 74
Comprehensive Physics Systems	Constant Force Cart ..... 102	Cuvettes,
850 Complete ..... 76-77	Constant Speed Buggy ..... 123	Turbidity Replacement ..... 60, 73
850 Thermodynamics/Waves ..... 77	Constant Velocity Cart –	
850 Electricity/Magnetism ..... 77	See Motorized Cart ..... 102	– D –
850 Mechanics ..... 79	Constant Velocity Tubes ..... 123	Damped Harmonic Motion
Compression Accessory,	Constant Volume Gas Thermometer	Experiment ..... 324
Materials ..... 152	See Absolute Zero Apparatus ..... 197	Damped Pendulum ..... 167, 325
Compression Igniter ..... 195	Constants, Measurement of	Damping Accessory, Cart ..... 109
Computer Interfacing	Bohr Magnetron ..... 291	Damping Accessory, Magnetic ..... 109
550 Universal Interface ..... 10-11, 14	Charge of an Electron ..... 286	Data Logging ..... 17, 21
850 Universal Interface ..... 10-11, 12	Coulomb Constant ..... 293	DC Constant Voltage
AirLink ..... 10-11, 16		Power Supplies ..... 236
		DC Current Amplifier ..... 236

## Product and Topic

- DC Programmable  
Power Supply ..... 231
- Decade Capacitance Box ..... 239
- Decade Resistance Box ..... 239
- Demonstration Mirrors ..... 280
- Demonstration Spring Set ..... 156
- Demonstration  
Wave Spring..... 156, 251
- Density Circulation Model ..... 173
- Density Sets ..... 175
- Desktop Electricity Kit..... 213
- Detector Coil ..... 227
- Dew Point Sensor  
See Weather Sensor..... 72
- Diffraction Gratings ..... 275  
High Precision Slits,  
Basic Optics..... 269  
Optics Kit..... 267  
Sensor Based ..... 266  
Slits (Basic Optics) ..... 269
- Diffusion Cloud Chamber ..... 300-301
- Digital Adapter,  
ScienceWorkshop-to-PASPORT ..... 39
- Digital Calipers ..... 182
- Digital Tesla Meter ..... 230
- Digital Indicator ..... 227
- Digital LCR Meter ..... 241
- Digital Library..... 91
- Digital Multimeters..... 241
- Digital Photogate  
Timer System..... 113
- Digital Storage Oscilloscope ..... 240
- Digital Stopwatch ..... 116, 157, 188
- Digital VideoFlex, USB ..... 285
- Diode Laser ..... 269, 279
- Dip Needle ..... 229
- Discharge Sphere,  
Van de Graaff ..... 204
- Discover Centripetal Force..... 163
- Discover Density Set..... 175
- Discover Freefall System ..... 122
- Discover Friction Accessory..... 107
- Discover Pi Set..... 185
- Displacement Sensor ..... 33
- Dissolved O<sub>2</sub> Sensor, Optical..... 64
- Dissolved Oxygen Probe ..... 7
- Doppler Rocket..... 253
- Double-length Slinky..... 156, 251
- Double Rod Clamp ..... 179
- Driven Damped Harmonic  
Oscillator Experiment..... 324
- Driven Harmonic/  
Chaos Accessory ..... 26, 167
- Driver, Mechanical Oscillator ..... 110
- Driver, Mechanical Wave ..... 246-247
- Drop Counter, High Accuracy ..... 58
- Drop Shoot Accessory..... 128
- Dual Load Cell Amplifier..... 32
- Dual Pressure Sensor..... 41, 173
- Dynamics Cart Tracks..... 92, 99-100
- Dynamics Carts ..... 92, 98-99
- Dynamics Systems ..... 92-93
- Dynamics Track Mount  
Rotary Motion ..... 26, 112
- Dynamics Track Optics Kit ..... 270
- Dynamics Track Spring Set..... 111, 156
- Dynamics Track  
Support Reactions..... 132
- E —
- Earth's Magnetic Field  
Experiment ..... 341
- e-Book, Essential Physics ..... 84-86
- EcoChamber ..... 71
- Economy CASTLE Kit..... 214
- Economy Force Sensor..... 7
- Economy Resonance Tube ..... 248
- EcoZone System..... 71
- EKG Electrode Patches..... 66
- EKG Sensor ..... 66
- Elastic Bumper ..... 24, 112
- Elastic Wave Cord..... 184, 251
- Elasticity, Stress/Strain ..... 148-154
- Electric and Magnetic  
Interactions ..... 213
- Electric Circuits ..... 208-218
- Electric Field Mapper..... 205
- Electric Plume for Van de Graaff ..... 204
- Electric Whirl for Van de Graaff ..... 204
- Electrical Equivalent of Heat  
Experiment ..... 327
- Electricity Kit, Desktop..... 213
- Electricity Lab, Basic..... 213
- Electricity/Magnetism Option,  
850 Comprehensive..... 77
- Electrocardiogram Sensor..... 66
- Electrode Patches, EKG..... 66
- Electrode, pH..... 59
- Electrolysis—  
See Hydrogen Fuel Cell..... 219
- Electromagnetic Ring Launcher ..... 223
- Electrometer ..... 56, 206
- Electron Charge—  
Millikan Oil Drop ..... 286
- Electron Charge-to-Mass Ratio ..... 287
- Electronic Balances & Adapters ..... 186
- Electronics Laboratory, AC/DC..... 212
- Electroscope ..... 207
- Electrostatic Charge Experiment ..... 332
- Electrostatics Materials Kit ..... 207
- Electrostatics Systems  
Basic ..... 206  
Charge Producers ..... 207  
Charge Sensor..... 56, 206  
Conductive Shapes..... 207  
Conductive Spheres ..... 207  
Electrometer ..... 206  
Electroscope ..... 207  
Faraday Ice Pail..... 207  
Field Mappers ..... 205  
Materials Kit ..... 207  
Proof Planes ..... 207  
Replacement Pad Set..... 207  
Van de Graaff ..... 204  
Variable Capacitor..... 207  
Voltage Source ..... 207
- e/m Apparatus ..... 287
- e/m Replacement Tube..... 287
- End Stops, Track..... 112
- Energy Conservation ..... 314-315
- Energy Conversion  
See Generators ..... 220-222  
See Hydrogen Fuel Cell..... 219  
See Thermoelectric ..... 200
- Energy Systems  
Hydro Accessory..... 221  
Thermoelectric ..... 200  
Wind Turbine ..... 222
- Energy Transfer, Calorimeter ..... 194



## Product and Topic

- Flow Sensor, General..... 41, 69, 172-174  
 Fluid Flow..... 41, 70, 172-174  
 Fluids  
   Atmospheric Pressure Demo ..... 171  
   Bell Jar, Student..... 171  
   Flow Sensor..... 41, 70  
   Magdeburg Plates ..... 171  
   Pipe Network..... 172-174  
   Venturi Apparatus ..... 173-174  
 Flying Pig..... 163  
 Force Acceleration Sensor,  
   Wireless ..... 17, 22, 29, 34  
 Force Bracket ..... 30, 108  
 Force Platform Handle Set..... 31  
 Force Platform,  
   PASPORT 1-Axis..... 31, 139  
 Force Platform,  
   PASPORT 2-Axis..... 31, 139  
 Force Platform  
   Structures Bracket..... 31, 33, 147  
 Force Sensor  
   Bracket ..... 30, 108  
   Bumper Accessory Set..... 30  
   Collision Bracket ..... 30, 108  
   Handle Set, Force Platform..... 31  
   High Resolution..... 29  
   Magnetic Bumper Set..... 30  
   PASPORT ..... 7  
   Platform..... 31  
   Rocket Engine Test Bracket ..... 30  
   ScienceWorkshop ..... 28  
   Wireless, Acceleration..... 17, 22, 29, 34  
 Force Table..... 133  
 Forces on a Human Body—  
   see Force Platform ..... 31, 139  
 Four-Point Bending..... 153  
 Four Scale Meter Stick ..... 182  
 Franck-Hertz Apparatus ..... 289  
 Franck-Hertz Argon Tube..... 289  
 Franck-Hertz Tube Enclosure..... 289  
 Freefall—  
   See Coin and Feather Tube..... 123  
 Freefall Adapter ..... 39, 123  
 Freefall System, Discover ..... 122  
 Freefall Timer Adapter ..... 39, 123  
 Friction Accessory, Discover ..... 107  
 Friction Block..... 107  
 Friction Cart Accessory ..... 107  
 Friction Experiment, Sliding..... 310  
 Friction Trays ..... 107  
 Friction, Energy Transfer ..... 107  
 Frictional Energy Transfer  
   Experiment ..... 310  
 Friction, Magnetic —  
   See Cart Damping ..... 109  
 F-Stops-See Aperture ..... 257  
 Fuel Cell Tutorial Set..... 219  
 Function Generators  
   850 Interface ..... 12  
   High-Frequency ..... 237  
   Sine Wave Generator..... 245  
   Standard..... 238  
   Wide Range..... 237  
 Fur, Electrostatics..... 207
- G —
- Galvanometer Meter, Analog ..... 239  
 Galvanometer Sensor ..... 54  
 Gamma Sources..... 299  
 Gamma,  
   Ratio of Specific Heats ..... 331  
 Gas Law Adiabatic..... 195  
   Experiment,  
     Ratio of Specific Heats ..... 331  
   Heat Engine..... 27, 198-199  
   Ideal..... 196  
 Gas Sensor, CO<sub>2</sub> Wireless ..... 63  
 Gas Sensor, O<sub>2</sub>..... 63  
 Gas Thermometer, Constant Volume  
   See Absolute Zero Apparatus..... 197  
 Gauss — Magnetic Field Sensor ..... 55  
 Geiger-Müller  
   G-M Tube/Power Supply ..... 39, 61, 298  
   Intermediate Nuclear Lab ..... 296  
   Probe with Sample Holder ..... 298  
   Tube ..... 298  
 General Flow Sensor..... 41, 70  
   With Pitot Tube ..... 41, 69, 173-174  
   With Venturi Tube ..... 41, 69, 173-174  
 General Purpose  
   Digital Multimeter..... 241  
 General Science Sensor..... 56  
 Generator, Energy Transfer ..... 220-222  
 Generator, Hand Crank..... 211, 222  
 Generator, Hydro-Electric..... 221  
 Generator, Mini ..... 222  
 Generator, Propeller ..... 222  
 Generator, Sine Wave..... 245  
 Generator, Steam ..... 191  
 Generator, Wind Turbine..... 222  
 Geometric Lens Set..... 258  
 Glass Stirling Engine..... 200  
 Glassware ..... 175, 185  
 Gliders, Air Track..... 119  
 Global Positioning Sensor  
   See Wireless Weather..... 72  
 Glow String..... 184, 251  
 G-M Probe with Sample Holder ..... 298  
 G-M Tube/Power Supply  
   Sensor ..... 39, 61, 298  
 Goniometer Probe ..... 16, 67, 139  
 Goniometer..... 16, 67, 139  
 GPS Sensor ..... 7  
   See Wireless Weather..... 72  
 Graduated Cylinders ..... 175, 185  
 Graph Matching Experiment..... 21  
 Graph Match Software ..... 21  
 Graphing —  
   See PASCO Capstone..... 18-20  
 Gratings, Diffraction ..... 275  
 Gravitational Torsion Bands..... 292  
 Gravitational Torsion Balance..... 292  
 Gravity  
   Cavendish Torsion Balance ..... 292  
   Experiment ..... 317  
 Green Diode Laser ..... 269, 279  
 Green Laser Pointer ..... 279  
 Ground Glass Lenses ..... 258  
 Guard, Motion Sensor..... 24  
 Gyroscope, 3-Axis ..... 27, 168-169  
 Gyroscope, Bicycle Wheel ..... 170  
 Gyroscope, Demonstration ..... 27, 168-169  
 Gyroscope Disk and Mass ..... 170  
 Gyroscope Masses, Bicycle ..... 170  
 Gyroscope Mounting Bracket ..... 169
- H —
- Hall Effect Apparatus..... 290  
 Hand-Operated Vacuum Pump..... 282

- Hand-Crank Generator ..... 7  
 Hand-Crank Mini-Generator ..... 222  
 Hand-Grip Heart Rate Sensor ..... 7  
   Wireless ..... 67  
 Hand-Held Centripetal Force ..... 163  
 Handle Set, Force Platform ..... 31, 139  
 Heart Rate Sensors ..... 66-67  
 Heat Engine ..... 27, 198-199  
 Heat Engine Accessory ..... 199  
 Heat Engine Cycle Experiment ..... 330  
 Heat Engines, Stirling ..... 200  
 Heat Engine/  
   Gas Law Apparatus ..... 198-199  
 Heat Expansion ..... 190  
 Heat, Mechanical Equivalent of ..... 194  
 Heater-Stirrer ..... 58, 191  
 Heavy-Duty Ammeter ..... 239  
 Heavy-Duty Galvanometer ..... 239  
 Heavy-Duty Voltmeter ..... 239  
 Helmholtz Coils ..... 227  
 h/e Apparatus ..... 288  
 h/e Experiment ..... 355  
 High Accuracy Drop Counter ..... 58  
 High Accuracy Meter Sticks ..... 182  
 High Current Sensor,  
   PASPORT ..... 53  
 High Frequency High Power  
   Function Generator ..... 237  
 High Precision Diffraction Slits ..... 268  
 High Precision pH/Temp ..... 7  
 High Quality Gratings ..... 275  
 High Resolution Force Sensor ..... 29  
 High Resolution  
   Photogate Tape ..... 38, 97  
 High Sensitivity Light Sensor ..... 49  
 High Speed Rotating Mirror ..... 294  
 High Voltage Power Supply ..... 234  
 High Voltage Van de Graaff ..... 204  
 Hooke's Law Set ..... 155  
 Hooke's Law Spring Set ..... 155  
 Hooked Mass Sets ..... 187  
 Hooke's Law Experiment ..... 307  
 Hot Plate ..... 7  
 Hover Puck ..... 117  
 Hovercraft ..... 117  
 Hovercraft Blower ..... 117  
 Human Applications of Physics .... 138-139  
 Human Arm Model ..... 68, 138  
 Human Back Model ..... 145  
 Human Eye Model ..... 264-265  
 Human Structures  
   Arm Model ..... 145  
   Back Model ..... 145  
   Leg Model ..... 145  
   Set ..... 145  
 Humidity/Temp/Dew Point ..... 7  
   See Wireless Weather ..... 72  
 Hydraulic Jack ..... 179  
 Hydraulic and Pneumatic Structures ... 146  
 Hydro-Electric Generator ..... 221  
 Hydrogen Fuel Cells ..... 219
- I —
- I-beam, Super-Flex ..... 154  
 I-beam Set,  
   Structures Flexible ..... 147  
 Ice Melting Blocks ..... 192  
 Ideal Gas Law Apparatus ..... 196  
 Ideal Gas Law Experiment ..... 328  
 Ideal Gas Law Syringe ..... 196  
 Igniter, Compression ..... 195  
 Impulse Experiment ..... 311  
 Individual Sources ..... 299  
 Induction  
   Faraday's Law ..... 344  
   Lenz's Law ..... 229  
   Magnetic Force Accessory ..... 225  
   PASCO Coil ..... 227  
   Primary and Secondary Coils ..... 226  
   Ring Launcher ..... 223  
   RLC Circuit ..... 211  
 Induction Wand ..... 225  
 Inductor-Capacitor–  
   Resistor Network ..... 210  
 Inertia, Rotational Moment of ..... 160  
 Inertia Wands ..... 164  
 Infrared Light Sensor ..... 49  
 Inquiry-based Handbook,  
   HS Physics ..... 80, 82  
 Inquiry-based Physics Bundle ..... 81, 83
- Interfaces, Computer  
   550 Universal Interface ..... 10-11, 14  
   850 Universal Interface ..... 10-11, 12  
   AirLink ..... 10-11, 16  
   SPARKlink Air ..... 10-11, 16  
 Interface Overview ..... 10, 11  
 Interference and Diffraction of Light  
   Experiment ..... 353  
 Interferometer ..... 282-283  
 Interferometer Accessory Kit ..... 283  
 Intro Dynamics Systems ..... 92-93  
 Intro Optics System .....  
 254-255 .....  
 Inverse Square Law,  
   See Light Intensity ..... 352  
 Ion-Selective Electrodes ..... 59  
 ISE Amplifier ..... 59  
 Isogenerator Kit  
   (Barium-137m) ..... 299  
 Isotope Generator, Radioactive ..... 299
- J —
- Jack, Hydraulic/Pneumatic ..... 179  
 Jacks, Lab ..... 179  
 Joule Equivalent of Heat ..... 194  
 Jumping Ring -  
   See Ring Launcher ..... 223
- K —
- Kilovolt Power Supply ..... 234  
 Kirchhoff's Circuit Laws  
   Experiment ..... 340  
 Knife Switches ..... 218
- L —
- Lab Jacks ..... 179  
 Lab Manuals ..... 78, 80, 82  
 Lamp, Stefan Boltzmann ..... 202  
 Large Amplitude Pendulum  
   Experiment ..... 323  
 Large Rod Stand ..... 176  
 Large Structures Set ..... 144  
 Large Table Clamp ..... 179  
 Laser Alignment Bench ..... 279  
 Laser Pointer, Green ..... 279  
 Laser Pointer, Red ..... 279  
 Laser Speed of Light ..... 295

## Product and Topic

Lasers			
Diode, Basic Optics .....	269, 279		
Green Diode .....	269, 279		
Helium-Neon .....	279		
Laser Alignment Bench .....	279		
Mini .....	279		
Modulated .....	279		
Pointer .....	279		
Red Diode .....	269, 279		
Launchers			
Projectile .....	124-125		
Ring .....	223		
Spring Cart .....	106		
LCR Meter, Digital .....	241		
Leads— Patch Cords .....	216		
Leaf Blower .....	117		
LED Indicator for Coils .....	227		
Lens, Adjustable .....	258, 265		
Lens Holder, Adjustable .....	257		
Lens Holder Set .....	257		
Lens Replacement Set,			
Human Eye .....	264		
Lens Set, Accessory .....	258		
Lens Set, Basic Optics Geometric .....	258		
Lenses .....	258		
Lenses, Basic Optics .....	258		
Lenz's Law Demonstration .....	229		
Leslie's Cube .....	202		
Level, Spirit .....	184		
Light Bulbs .....	218		
Light Bulb Sockets .....	218		
Light Intensity vs. Distance			
Experiment .....	352		
Light Sensors			
Aperture Bracket .....	269		
Broad Spectrum .....	48		
General Science Sensor .....	56		
High Sensitivity .....	49		
Infrared .....	49		
Light Level, Wireless .....	48		
PASPORT .....	49		
RGB .....	48		
ScienceWorkshop .....	47		
Temperature/Sound/Light .....	57		
UVA & UVB .....	48		
Wireless .....	48		
Light Sources			
Basic Optics .....	256		
Black Body Light Source .....	276		
Diode Laser .....	269, 279		
Lasers .....	269, 279		
Mercury Vapor Lamp .....	278		
Millikan LED .....	286		
Replacement Lamps .....	278		
Ripple Generator .....	243		
Spectral Sources .....	278		
Spectral Tube Power Supply .....	278		
Stefan-Boltzmann Lamp .....	202		
Light, Speed of .....	294-295		
Linear Motion Accessory .....	25		
Linear Polarizer .....	263		
Linear Translator .....	27, 269		
Liquid-Filled Compass .....	230		
Load Cell, 5 N .....	33		
Load Cell, 100 N .....	33		
Load Cell Amplifiers .....	32		
Load Cell and Amplifier Sets .....	32, 140		
Longitudinal Wave Spring .....	156, 251		
Low Pressure Sensor			
See Wireless Pressure .....	43		
Low Voltage AC/DC			
Power Supply .....	235		
LRC Circuit Experiment .....	339		
LRC Meter, Digital .....	241		
<b>— M —</b>			
Magdeburg Plates .....	171		
Magnaprobe .....	229		
Magnet, Variable Gap .....	225		
Magnetic Bumper Set .....	30, 108		
Magnetic Compass .....	230		
Magnetic Damping Accessory .....	109		
Magnetic Demonstration System .....	224		
Magnetic Dip Needle .....	229		
Magnetic Drag Demo—			
See Lenz's Law .....	229		
Magnetic Field Demonstrator .....	229		
Magnetic Field Sensor,			
PASPORT .....	54-55		
ScienceWorkshop .....	55		
2-axis .....	55		
Magnetic Fields of Coils			
Experiment .....	343		
Magnetic Force Accessory .....	225		
Magnetic Forces on Wires .....	342		
Magnetic Motion Sensor Bracket .....	24		
Magnetic Stirrer .....	7		
See Heat-Stirrer .....	58, 191		
Magnets .....	230		
Malus' Law of Polarization .....	350		
Manganese-54 .....	299		
Manuals			
Comprehensive Physics			
Systems .....	76-77		
High School Advanced			
Physics .....	80, 82		
High School Physics Inquiry .....	80, 82		
STEM .....	88-90		
Mass and Hanger Sets .....	186-187		
Mass Balances .....	186		
Mass Set, Gyroscope .....	170		
Mass Set, Ohaus Additional .....	186		
Mass Set, Spherical (balls) .....	183		
Mass Sets .....	186-187		
Mass, Cart .....	99, 111		
MatchGraph App .....	21		
Materials .....	148-154		
Materials Testing,			
10-32 Adapter .....	153		
Apparatus .....	150		
Bending Accessory .....	153		
Clevis Grip .....	153		
Comprehensive .....	148		
Compression Accessory .....	152		
Flat Coupon Fixture .....	153		
Machine .....	150		
Photoelasticity Accessory .....	152		
Shear Accessory .....	152		
Shear Samples .....	152		
Storage Base .....	152		
Structures Beam Fixture .....	152		
Systems .....	148-150		
Tensile Samples .....	150		
Matter Model .....	154		
Measuring Tape, Metric .....	182		
Mechanical Equivalent of Heat .....	194		
Mechanical Equivalent of Heat			
Brush .....	194		

Mechanical Equivalent of Heat Cylinder .....	194	Mini Launcher Ballistic Accessory .....	131	Non-Contact Temperature Sensor .....	46
Mechanical Oscillator/Driver .....	110	Mini Launcher Spares Kit .....	125	Nuclear Sensors— See G-M Tube .....	39, 61, 298
Mechanical Wave Driver .....	246	Mini Rotational Accessory .....	25, 165	Nuclear Spectroscopy, USB .....	296
Mechanical Wave Driver Accessories .....	246-247	Mini Speaker .....	249	Nuclear Systems .....	296-297
Mechanics System with 850 Probeware .....	79	Mirror, Concave/Convex .....	280	— O —	
Melting Block, Ice .....	192	Mirror, High Speed Rotating .....	294	O <sub>2</sub> Gas Sensor .....	63
Mercury Vapor Lamp .....	278	Mirrors, Demonstration .....	280	O.D.O. Sensor .....	64
Metal Knobs and Feet .....	176	Modular Circuits .....	208-209	Ohaus Balances .....	18
Metal Resonance Strips .....	247	Modular LED Strobe .....	189, 244	Ohaus Balance Adapters .....	186
Meter Stick .....	182	Modulated Laser .....	279	Ohaus Mass Sets .....	186
Meter Stick, Four Scale .....	182	Modules, Essential Physics .....	88-90	Ohmmeters .....	241
Meters		Moisture/Humidity Sensor .....	70	Ohm's Law Experiment .....	337
Analog Meters .....	241	See Wireless Weather .....	72	Oil, Mineral Replacement .....	286
Digital Multimeters .....	241	Moisture Sensor, Soil .....	73	Open Speaker .....	248
Galvanometer .....	239	Mole Set .....	175	Optical Dissolved Oxygen Metal Guard .....	64
Heavy-Duty Student Meters .....	239	Moment of Inertia Experiment .....	319	Replacement Cap .....	64
LRC Digital Meter .....	241	Monkey Hunter Demonstration (Shoot the Target) .....	127	Sensor .....	64
Magnetic Field .....	230	Motion Graph Matching Experiment .....	21	Optics Bench .....	259
Temperature Meter .....	241	Motion Sensor .....	24	Optics Bench Rod Clamp .....	259
Tesla .....	230	Cart Adapter .....	24	Optics Caliper .....	265
Metric Measuring Tape .....	182	Elastic Bumper .....	24	Optics Carriage, Dynamics Track .....	270
Metric Spring Scales .....	181	Guard .....	24	Optics Kit, Diffraction .....	267
Michelson Interferometer .....	282	Magnetic Motion Sensor Bracket .....	24	Optics Kit, Dynamics Track .....	270
Micro Stir Bar .....	58	PASPORT .....	24	Optics, Microwave .....	284
Micrometer .....	182	Rotary .....	25	Optics Kit, Ray .....	256
Microscope/Telescope Experiment .....	349	Science Workshop .....	24	Optics Systems Basic .....	254-255
Microscope, USB Camera .....	285	Motor Drive, Rotational .....	161	Diffraction, Sensor-Based .....	266
Microscope, VideoFlex .....	285	Motorized Cart .....	102	Dynamics Track Optics Kit .....	270
Microwave Accessories Package .....	284	Mount, Dynamics Track .....	26, 112	Microwave .....	284
Microwave Detector Probe .....	284	Mounting Bracket for .....		Optics, Eye .....	264-265
Microwave Mounting Stand .....	284	Photogates .....	129	Optics, Ray Table .....	256
Microwave Optics System .....	284	Mounting Stand, Microwave .....	284	ORP Probe .....	59
Microwave Receiver .....	284	Multi-Clamp .....	178	Oscillator/Mechanical Driver .....	246
Millikan LED Light Source .....	286	Multimeters, Digital .....	241	Oscilloscope .....	240
Millikan Oil Drop Apparatus .....	286	— N —		Overflow Can .....	175
Mineral Oil .....	286	N-Doped Germanium, Hall Effect .....	290	Oxidation Reduction Potential Probe .....	59
Mini Cars, Roller Coaster .....	120	Neodymium Magnet .....	230	Oxygen Gas Sensor .....	63
Mini Cars, Structures .....	120	Network, Pipe .....	172-174	— P —	
Mini Generator, Hand-Crank .....	222	Network, RC .....	211	Paper, Conductive .....	205
Mini Laser .....	279	Network, RC Inductor .....	13, 210	Parallel Spring Bracket .....	155
Mini Launcher .....	125	Newton's Laws Experiment .....	306	Paramagnetism— See Magnetic Force Acc. ....	225
		No Bounce Ball Set .....	183		
		No Bounce Pad .....	184		

## Product and Topic

- Partial Immersion Thermometer ..... 201
- PAScars ..... 92, 99
- PAScar Dynamics Systems ..... 92-93
- PAScar Mass ..... 99, 111
- PAScar Replacement Wheel/  
Axle Set ..... 111
- PASCO Capstone ..... 18-20
- PASCO Capstone Experiments ..... 302-357
- PASCO Stopwatch ..... 116, 157, 188
- PASPORT Interfaces ..... 10-16
- PAstrack ..... 99-100
- PAstrack, Curved ..... 100
- PAstrack Dynamics Systems ..... 92-93
- Patch Cords
- 2-meter ..... 216
  - Long ..... 216
  - Short ..... 216
  - Shrouded ..... 216
- Patches,
- Replacement Adhesive ..... 45
- Pb-210 Cloud Chamber Source ..... 301
- Pen, Conductive Ink ..... 205
- Pendulum
- Accessory ..... 165
  - Ballistic ..... 130
  - Ballistic, Accessory ..... 26, 131
  - Ballistic, Mini Launcher ..... 26, 131
  - Centripetal Force ..... 26, 163
  - Clamp ..... 156-157, 178
  - Damped ..... 26, 167
  - Physical Experiment ..... 320
  - Physical Set ..... 166
  - Set, Photogate Pendulum ..... 157
  - Torsion ..... 166
- Pendulum Accessory ..... 165
- pH Electrode, Flat ..... 59
- pH Sensor, PASPORT ..... 7
- pH Sensor, Wireless ..... 59
- pH - ORP & ISE probes ..... 59
- Phone Jack Extender Cable ..... 39
- Photoelasticity Accessory ..... 152
- Photoelectric Effect Experiment ..... 355
- Photoelectric Effect System ..... 288
- Photoelectric Effect,  
Tube with Box Plate ..... 288
- Photogate Port–  
See Digital Adapter ..... 39
- Photogate, Smart Gate ..... 36, 96, 157
- Photogate Timer ..... 113
- Photogate/Pulley System ..... 137, 180
- Photogates and Accessories ..... 36-38
- Accessory Photogate ..... 37
  - Bracket for Dynamics Track ..... 97
  - Bracket for Projectile Launcher ..... 129
  - Dynamics ..... 38, 97
  - Fences ..... 38, 97
  - High Resolution Photogate Tape ..... 38, 97
  - Mounting Bracket ..... 97
  - Mounting Rod for Rotational ..... 169
  - Mounting Rods ..... 137, 177, 180
  - Pendulum Set ..... 37, 157
  - Photogate Head ..... 37
  - Photogate Port–  
See Digital Adapter ..... 39
  - Photogate Stand ..... 37
  - Picket Fence, Cart ..... 38, 97
  - Picket Fence, Large ..... 38
  - Picket Fence, Smart Timer ..... 38, 97
  - Pulley System ..... 37, 180
  - Smart Gate Pulley ..... 36
  - Smart Timer ..... 114
  - Smart Timer Photogate  
System ..... 114-115
  - Smart Timer Picket Fence ..... 38, 97
  - Stand-Alone Timers ..... 113-116
  - Tape Set ..... 38, 97
  - Timer ..... 113
- Photosynthesis Tank ..... 64
- Physical Pendulum Experiment ..... 320
- Physical Pendulum Set ..... 166
- Physics Lab Manuals ..... 78, 80, 81
- Physics Probeware Bundles ..... 76-83
- Physics Stem Modules ..... 88-90
- Physics String ..... 184
- Physics Textbook ..... 84-86
- Physiology Sensors
- Blood Pressure ..... 65
  - Breath Rate ..... 68
  - EKG Sensor ..... 66
  - Exercise Heart Rate ..... 66
  - Goniometer Sensor ..... 67, 139
  - Hand-Grip Heart Rate ..... 67
  - Human Arm Model ..... 68, 138
  - Spirometer ..... 68
- Pi Set, Discover ..... 185
- Picket Fence, Cart ..... 38, 97
- Picket Fence, Large ..... 38
- Picket Fence, Smart Timer ..... 38, 97
- Pig, Flying ..... 163
- Pipe Network ..... 172-174
- Pitot Tube ..... 41, 69
- Pivot Clamp, Dynamics Track ..... 112
- Planck's Constant,  
see Photoelectric Effect ..... 288, 355
- Plastic Balls ..... 129, 183
- Plastic Storage Bins ..... 175
- Plastic Tracks ..... 99-101
- Platform, Chair ..... 170
- Platform, Force ..... 31, 139
- Platform, Rotating ..... 160
- Plotting Compass ..... 230
- Plumb Bobs ..... 129, 184
- Plumb Bobs,  
Projectile Launcher ..... 129
- Plume, Van de Graaff ..... 204
- Plunger Cart ..... 92, 99
- Pneumatic Structures ..... 146
- Pointer, Laser ..... 279
- Polarimeter ..... 62
- Polarimetry Demonstration ..... 62, 261
- Polarization Analyzer ..... 27, 262
- Polarization of  
Light Experiment ..... 350
- Polarizer, Calibrated ..... 27, 262
- Polarizer Demonstrator ..... 62, 261
- Polarizer Demonstrator  
Accessory ..... 62, 261
- Polarizer, Linear ..... 263
- Polarizer Set, Basic Optics ..... 263
- Polonium-210 ..... 299
- Position Sensor, GPS  
See Wireless Weather ..... 72
- Power Supplies, AC and DC
- 18 VDC, 3A ..... 232
  - 18 VDC, 5A ..... 232
  - 30 VDC, 6A ..... 233
  - AC/DC ..... 235



## Product and Topic

- Resistivity Experiment ..... 336  
 Resistivity—  
   see Resistance Apparatus ..... 215  
 Resistor Assortment ..... 217  
 Resistor-Capacitor Circuit ..... 7  
 Resistor Capacitor Inductor  
   Network..... 13, 211  
 Resonance Air Column  
   with or without Speaker ..... 249  
 Resonance Box Set ..... 253  
 Resonance Strips, Metal ..... 247  
 Resonance Structures System ..... 247  
 Resonance Tube ..... 249  
 Resonance Tube, Economy ..... 248  
 Resonance Wire Loop ..... 247  
 Respiration Clips ..... 68  
 Respiration Mask ..... 68  
 Right Angle Clamp ..... 178  
 Right Angle Prism ..... 280  
 Ring Launcher ..... 223  
 Ring Launcher Accessories ..... 223  
 Ripple Generator/  
   Light Source ..... 243  
 Ripple Tank System ..... 242-243  
 RLC Circuit ..... 211  
 Rocket Engine Test Bracket ..... 30  
 Rocket, Doppler ..... 253  
 Rod Clamp, Optics Bench ..... 259  
 Rod Stand, Large ..... 176  
 Rod, Flex ..... 177  
 Rod, Pulley Mounting ..... 137, 177, 180  
 Rods, Stainless Steel ..... 176  
 Roller Coaster ..... 120-121  
 Rotary Motion Sensors ..... 25-27  
   A-base Adapter ..... 169  
   Ballistic Pendulum  
     Accessory ..... 26, 131  
   Centripetal Force  
     Pendulum ..... 26, 163  
   Chaos/Driven Harmonic  
     Accessory ..... 167  
   Damped Pendulum ..... 28, 167  
   Dynamics Track Mount ..... 26, 112  
   Gyroscope ..... 27, 169  
   Gyroscope Mounting Bracket ..... 169  
   Heat Engine ..... 27, 198  
   Linear Accessory Kit ..... 25  
   Linear Translator ..... 27, 269  
   Mini-Rotational Accessory ..... 25, 165  
   Pendulum Accessory ..... 165  
   Polarization Analyzer ..... 27, 262  
   Spectrophotometer ..... 26, 274-275  
   Track String Adapter ..... 26  
 Rotating Chair ..... 170  
 Rotating Platform ..... 160  
 Rotational Accessory,  
   Mini (Rotary Motion) ..... 25, 165  
 Rotational Adapter, A-base ..... 161, 169  
 Rotational Apparatus, .....  
 Rotational Inertia Accessory ..... 160  
 Rotational Inertia Experiment ..... 319  
 Rotational Inertia Set ..... 164  
 Rotational Inertia Wands ..... 164  
 Rotational Motor Drive ..... 161  
 Rotational System, Complete ..... 158-159  
 Rubber Cord ..... 111, 119, 184
- S —
- Salinity Sensor ..... 70  
 Scaler/Timer, G-M System ..... 296  
 Scales, Electronic ..... 186  
 Scales, Spring ..... 181  
 ScienceWorkshop  
   Cable, 8-pin DIN Extender ..... 13, 22  
 Scout Pro Balance, Ohaus ..... 186  
 Screen, Basic Optics ..... 259  
 Sensor-based Diffraction Kit ..... 266  
 Sensor-based Diffraction System ..... 266  
 Sensor Extension Cables ..... 22  
 Sensor Index ..... 23  
 Sensor, Rotary –  
   Mounting Accessory ..... 169  
 Sensor Options ..... 17, 22  
 Series/Parallel Battery Holder ..... 218  
 Series/Parallel Circuit ..... 7  
 Series/Parallel Spring Set ..... 155  
 Shaking Towers and Bridges ..... 356-357  
 Shapes, Conductive ..... 207  
 Shear Accessory, Materials ..... 152  
 Shoot-the-Target Accessory ..... 127  
 Shrouded Alligator Clips ..... 217  
 Shrouded Alligator Test Leads ..... 217  
 Shrouded Cables ..... 13  
 Sights, Projectile Launchers ..... 129  
 Signal (Function) Generators ..... 237-238  
 Silicone Oil ..... 286  
 Sine Wave Generator ..... 245  
 Single Section Wave Motion ..... 250  
 Skin/Surface Temp Sensor ..... 45  
 Sliding Friction Experiment ..... 310  
 Slinky, Double Length ..... 156, 251  
 Slit Set, Basic Optics  
   (High Resolution) ..... 268  
 Slotted Mass Sets and  
   Hangers ..... 186-187  
 Small “A” Base ..... 176  
 Small Round Base w/Rod ..... 177  
 Smart Cart Charging Garage ..... 98  
 Smart Cart Curved Track System ..... 100  
 Smart Cart Dynamics System ..... 92-93  
 Smart Carts, Wireless ..... 92, 94, 98  
 Smart Fan Accessory ..... 103  
 Smart Gate, Photogate ..... 36, 96, 157  
 Smart Gate Pulley System ..... 36, 137, 180  
 Smart Gate System ..... 36, 96, 157  
 Smart Pulley—  
   see Super Pulley ..... 137, 180  
 Smart Timer ..... 114-115  
 Smart Timer Photogate System ..... 115  
 Snakey ..... 156, 251  
 Sockets, Light Bulb ..... 218  
 Sodium-22 Source ..... 299  
 Software  
   MatchGraph App ..... 21  
   PASCO Capstone ..... 18-20  
   SPARKvue ..... 21  
   Spectrometer ..... 21, 62, 272-273  
 Soil Moisture Sensor ..... 73  
 Solenoid, Air Core ..... 226  
 Sonic Ranger –  
   See Motion Sensor ..... 24  
 Sound Level Sensor ..... 57  
 Sound Sensor ..... 57  
 Sources, Radioactive ..... 299  
 Spares  
   Basic Optics ..... 259  
   Capacitor Assortment ..... 217  
   Dynamics System Kit ..... 112

Launchers .....	124-125	Spherical Aberration– See Aperture Access. ....	257	Stopwatch, PASCO.....	116, 157, 188
Resistor Assortment.....	217	Spherical Mass Set (Balls) ..	129, 164, 183	Storage Bins, Plastic.....	185
Roller Coaster.....	120	Spirit Levels .....	184	Strain Gauge– See Force Sensor .....	28-31
Rotary Motion Sensor .....	25-27	Spirometer Mouthpieces .....	68	Stress/Strain Test Coupons .....	154
SPARKlink Air.....	10-11, 16	Spirometer.....	68	String Adapter, Track .....	26
SPARKlink Air, Charging Station.....	16	Spring Bracket, Parallel .....	155	String Vibrator.....	244
SPARKvue, Software.....	21	Spring Cart Launcher .....	106	String, Braided .....	111, 184
Speaker, Open.....	248	Springs		String, Glow .....	184, 251
Speaker, Resonance Air Column.....	249	Accelerometer.....	121	String Holder, Wave Driver.....	247
Specific Gravity – See Density .....	175	Demonstration Set.....	156	Strobe.....	189, 244
Specific Heat Experiment .....	326	Demonstration Wave .....	156, 251	Strobe, LED Modular.....	189, 244
Specific Heats of Gases, Ratio of.....	331	Dynamics Track .....	111	Strontium-90 .....	299
Specific Heat Set.....	193	Equal Length.....	155	Structural Strength, Beam Stiffness Structures Beam Fixture .....	152
Spectral Lamps .....	278	Hooke’s Law .....	155	Structures Systems and Accessories #6 I-Beam .....	147
Spectral Light Sources.....	278	Longitudinal Wave .....	156, 246	Advanced Set.....	143
Spectral Tubes, Power Supply .....	278	Series/Parallel.....	155	Axle Spares .....	147
Spectrometer, Computer-based .....	21, 62, 272-273	Spring Scale– See Tension Protractor.....	134, 181	Beams.....	147
Spectrometer, Student.....	277	Spring Scales .....	181	Bracket, Force Platform.....	31, 33, 147
Spectrometer System, Nuclear Radiation .....	297	Stackable Plastic Bins.....	185	Bridge Set.....	142
Spectrometer, Wireless .....	21, 62, 272-273	Stainless Steel Calipers.....	182	Cast Beams .....	146
Spectrometry Computer-based .....	21, 62, 272-273	Stainless Steel Rods.....	176	Connectors .....	147
Educational.....	274-275	Stainless Steel Temp Probe.....	45	Cord Lock Spares .....	147
Prism Spectrophotometer .....	276	Stainless Steel Temp Sensor.....	44	Flexible I-Beam Set.....	147
Spectral Light Sources.....	278	Stands, Rod.....	176-177	Force Platform Bracket.....	31, 33, 147
Spectroscopy Nuclear Lab .....	297	Stand-alone Timers.....	116	Hydraulic and Pneumatic .....	146
Student Spectrometer.....	277	Starter Aluminum Tracks .....	99	Large Set.....	144
Wireless .....	21, 62, 272-273	Starter System, 850 Comprehensive Electromagnetism .....	77	Load Cells & Amplifiers .....	32-33, 140
Spectrophotometer, Accessory Kit.....	275	Physics.....	76	Mini Car Set.....	120
Educational.....	274-275	Mechanics.....	79	Resonance .....	247
Rotary Motion .....	26, 274-275	Waves, Optics, Thermodynamics.....	77	Roadbed Spares .....	147
Spectrophotometer, Prism .....	276	Static Equilibrium– See Statics System.....	135	Rod Clamps .....	147
Speed of Sound (Resonance).....	248-249	See Tension Protractor.....	134, 181	Roller Coaster Track.....	120
Speed of Light Apparatus .....	294, 295	Statics System .....	135	Shaking.....	356-357
Speed of Light Experiment .....	348	Steam Generator.....	191	Structures Sets.....	140-146
Speed of Light System, Laser .....	295	Steel Balls.....	129, 183	Track Spares.....	147
Speed, Constant.....	102-103	Steel Rods.....	176	Truss Set.....	141
Sphere, Discharge.....	204	Stefan-Boltzmann Lamp.....	202	Truss Set Members .....	147
Spheres, Conductive .....	207	Stirling Engine.....	200	Truss Set Screws.....	147
		Stirrer, Heat.....	58, 191	Vibrations .....	247
		Stool, Rotating .....	170	Student Bell Jar .....	171
		Stopwatch 10-Pack, PASCO.....	157, 188	Student Power Supply .....	232
				Student Spectrometer.....	277

## Product and Topic

Student Timer.....	188	Type K Probe.....	46	Toys, Physics
Suction Cup–		Type K Thermocouple.....	46	Air Cannon.....
See Air Pressure Demo.....	171	Weather, Wireless.....	72	Bounce/No Bounce Balls/Pad... 183-184
Super-Flex I-Beam.....	154	Wireless.....	17, 46	Constant Speed Buggy.....
Super Pulley.....	137, 180	Tensile Samples,		Doppler Rocket.....
Super Pulley Combination.....	137, 180	Materials Tester.....	150	Flying Pig.....
Super Pulley Force Table.....	133	Tensile Tester.....	148-150	Glow String.....
Super Pulley with Clamp.....	137, 180	Tension Protractor.....	134, 181	Hover Puck.....
Super Pulley with		Tesla Meter.....	230	Slinky, Double-length.....
Mounting Rod.....	137, 180	Test Coupons, Stress/Strain.....	154	Track String Adapter,
Support Reactions,		Test Kits, ezSample.....	75	Rotary Motion.....
Dynamics Track.....	132	Test Leads, Alligator Shrouded.....	217	Track, Air.....
Support Rods and Base.....	177	Textbook - Essential Physics.....	84-86	Track, Dynamics.....
Support, Technical.....	Inside Back Cover	Thallium-238.....	299	Track, Dynamics.....
Switch Set, Knife.....	218	Thermal Conductivity		Track Mount for
Swivel Clamp.....	179	Apparatus.....	192	Rotary Motion Sensor.....
Sympathetic Resonance		Thermal Expansion Apparatus.....	190	Track, Optics.....
Box Set.....	253	Thermal Imaging Camera.....	201	Track, Roller Coaster.....
		Thermal Radiation Cans.....	202	Training.....
		Thermal Radiation Cube.....	202	Transformer Coils.....
		Thermal Radiation Lab.....	203	Translator, Linear.....
		Thermal Radiation Sensor.....	202	Transmitter Probe, Microwave.....
		Thermocline Sensor.....	69	Transverse Wave
		Thermocouple Probe		Demonstrator.....
		(Multimeter).....	241	Triple Output Power Supply.....
		Thermoelectric Converter.....	200	Triple-Beam Balance.....
		Thermometers		Tripod, Weather Sensor.....
		Constant Volume Gas.....	197	Truss Set.....
		Partial Immersion.....	201	Tube, Coin and Feather.....
		Thread, Black.....	184	Tube, Resonance.....
		Three-Axis Acceleration Altimeter.....	35	Tubes, Constant Velocity.....
		Three-Finger Clamp.....	178	Tunable DC Power Supply.....
		Three-Point Bending.....	153	Tuning Fork Set.....
		Ticker-Tape Timer.....	116	Tungsten Balls,
		Time-of-Flight		Gravitational Torsion.....
		Accessory.....	37, 39, 126, 129	Turbidity Sensor, PASPORT.....
		Timer, Student.....	188	See Wireless Colorimeter
		Freefall Adapter.....	39, 123	w/Turbidity.....
		Photogate Timer.....	113	Turbine Generator.....
		Smart Timer.....	114-115	Type K Temperature Sensor.....
		Stopwatch, Digital.....	116, 188	
		Student.....	188	
		Tape Timer.....	116	
		Torsion Bands,		
		Replacement Gravitational.....	292	
		Tower, Shaking.....	356-357	

## - T -

## - U -

- Universal Table Clamp ..... 179  
 USB Bluetooth 4.0 Adapter ..... 17, 22  
 USB Camera Microscope ..... 285  
 USB Charging Station, 10-port ..... 16  
 USB Digital VideoFlex ..... 285  
 Utility/Buret Clamp ..... 178  
 UVA Light Sensor .....  
     See Wireless Light Sensor ..... 48  
     **– V –**  
 Vacuum  
     Bell Jar ..... 171  
     Coin and Feather Tube ..... 123  
     Magdeburg Plates ..... 171  
 Vacuum Pump, Hand-operated ..... 282  
 Van de Graaff Generator ..... 204  
 Vane, Weather Accessory ..... 73  
 Variable Capacitor ..... 207  
 Variable Gap Lab Magnet ..... 225  
 Variable Output Air Supply ..... 119  
 Variable Speed Motorized Cart ..... 102  
 Variable-g Experiment ..... 322  
 Vectors – See Force Table ..... 133  
 Vectors, Video Analysis ..... 20  
 Velocity Buggy, Constant ..... 123  
 Velocity Cart, Constant ..... 102  
 Velocity Tubes, Constant ..... 123  
 Venturi Tubes ..... 41, 69, 173  
 Vernier Calipers ..... 182  
 VI Sensor ..... 53  
 Vibrations,  
     Bridge Experiment ..... 356-357  
 Vibrating String Experiment ..... 345  
 Vibrator, String ..... 244  
 Video Capture and Analysis ..... 20  
 VideoFlex Microscope ..... 285  
 Viewing Screen, Basic Optics ..... 259  
 Violin Chladni Plate ..... 246  
 Visual Accelerometer ..... 34, 105  
 Voltage Sensors  
     550 & 850 ..... 50-51  
     PASPORT ..... 53  
     ScienceWorkshop ..... 50-51  
     Shrouded ..... 50-51  
     Wireless ..... 52  
 Voltage Source, Electrostatics ..... 207  
 Voltage/Current Sensor ..... 53  
 Voltage & Current, Wireless ..... 52  
 Voltmeter, Analog ..... 239  
 Volumetric Flow Rate ..... 41, 172-174  
     **– W –**  
 Wand, Induction ..... 225  
 Wands, Rotational Inertia ..... 164  
 Water Flow ..... 172-174  
 Water Quality Colorimeter ..... 75  
 Water Quality,  
     ezSample Test Kits ..... 75  
 Water Reservoir ..... 185  
 Water Velocity ..... 172-174  
 Waterproof Caliper, Optics ..... 265  
 Wave Cord, Elastic ..... 184, 251  
 Wave Driver, Mechanical ..... 246  
 Wave Motion Actuator ..... 250  
 Wave Motion Demonstrator ..... 250  
 Wave Spring,  
     Demonstration ..... 156, 251  
 Waves Experiment ..... 346  
 Weather/Anemometer ..... 7  
 Weather Sensor, Wireless ..... 72  
 Weather Vane Accessory ..... 73  
 Wheel/Axle Replacement Set ..... 111  
 Wide Range Function Generator ..... 237  
 Wind Turbine, Energy Transfer ..... 222  
 Wind Turbine Propeller ..... 222  
 Wind/Weather Sensor, Wireless ..... 72  
 Wire Loop, Resonance ..... 247  
 Wireless Sensor Adapter ..... 17, 22  
 Wireless Interfaces ..... 16  
 Wireless Sensors  
     Carbon Dioxide ..... 64  
     CO<sub>2</sub> Gas ..... 17, 63  
     Colorimeter and Turbidity ..... 60, 74  
     Conductivity ..... 17, 74  
     Current ..... 17, 52  
     Current Module ..... 208-209  
     Exercise Heart Rate ..... 66  
     Force Acceleration ..... 17, 29, 34  
     Hand Grip Heart Rate ..... 67  
     Light ..... 17, 48  
     pH ..... 17, 59  
     Polarimeter ..... 62  
     Pressure ..... 17, 43  
     Smart Carts ..... 1, 94, 98  
     Spectrometer ..... 21, 62, 272-273  
     Temperature ..... 17, 46  
     Voltage ..... 17, 52, 208-209  
     Weather with GPS ..... 72  
     Wireless Polarimeter ..... 62  
     Wireless Smart Carts ..... 1, 94, 98  
     Wireless Spectrometer ..... 21, 62, 272-273  
 Wires, Resistance Replacement ..... 215  
 Work Energy Theorem  
     Experiment ..... 316  
 Workshop Physics  
     Chaos Accessory ..... 26, 167  
     Coils, Detector and Field ..... 227  
     Equal Arm Balance ..... 132  
     Heat Engine/Gas Law  
         Apparatus ..... 198-199  
         Mechanical Oscillator/Driver ..... 110  
     **– X –**  
 Xplorer GLX  
     Replacement Batteries ..... 7  
     AC Power Adapter ..... 7  
     AC Power Adapter - 220 ..... 7  
     **– Y –**  
 Yellow Cord ..... 184  
 Young's Modulus –  
     See Materials Testing ..... 148-153  
     **– Z –**  
 Zeeman Effect ..... 291  
 Zero, Absolute ..... 197  
 Zero Gauss Chamber ..... 55

# Terms and Conditions

## The PASCO Promise of Learning (90-day Satisfaction Guarantee)

We are confident that PASCO solutions will help your students achieve more in science. Within the first 90 days, if you are not satisfied that your students are more engaged and learning more effectively, return your purchase for a refund. We don't want you spending precious budget dollars on something you don't use. (We are sorry but we must exclude non-PASCO software that has been opened, radioactive products and products that contain perishables.) See instructions for Returns below.

## PASCO 5-Year Limited Warranty for Education

PASCO products are built to survive. PASCO-manufactured products are covered by a limited warranty for a period of 5 years from delivery date against defects in material and workmanship. This warranty is valid for educational institution customers and only for educational use of these products. The PASCO warranty does not extend to any product, including touch screens, which have been subject to abuse, neglect, accident, improper installation or application, or products that have been repaired or altered outside of our factory. Consumables and limited-life products (such as pH probes, membranes, fast response temperature probes, batteries, chemical solutions, printed materials, etc.) are excluded.

## Other Warranty Terms

Products manufactured by anyone other than PASCO are subject to the conditions of the warranty supplied by the manufacturer (generally 1 year). Additional warranty information on our products is available upon request.

## Free Teacher and Technical Support

We want teachers to be successful with PASCO solutions. Please contact our support team with any questions via phone or email. We are here to help. See our contact information below.

## Contact PASCO

### Mail:

**PASCO Scientific**  
10101 Foothills Blvd.  
Roseville, CA 95747-7100 U.S.A.

### Customer and Order Support:

+1 916-462-8383  
sales@pasco.com  
custserv@pasco.com

### Technical and Teacher Support:

+1 916-462-8384  
support@pasco.com

### Fax:

+1 916-786-7565

### Web Site:

**pasco.com**

### Business Hours:

Monday — Thursday: 7:00 a.m. — 4:30 p.m.  
Friday: 7:00 a.m. — 2:00 p.m. Pacific Time

## SPARKvue Licenses

SPARKvue software may be purchased as a Single License for use with one computer or as a Site License for use on all computers on a K-12 campus or in a college/university department. SPARKvue for iPad®, Chromebook™, or Android™ tablets is licensed separately and is free through the App Store, the Chrome Web Store and Google Play. See pasco.com for more information.

## PASCO Capstone Licenses

PASCO Capstone may be purchased as a Single License for use with one computer, or as a Site License for use on all computers on a primary and secondary campus or in a college/university department.

## Shipping

Items in stock will normally be shipped in less than seven working days from receipt of the order. Specific request for air shipments or special carriers will be honored at additional cost.

## Returns

Please contact the authorized PASCO representative in your country for assistance in returning equipment for repair. PASCO's International Customer Service team can be reached at +1-916-462-8383 or at custserv@pasco.com. Out-of-Warranty products must be shipped prepaid, door-to-door. Returns for credit or exchange must be in new condition and packaged in original shipping cartons or packaging sufficient to prevent damage during international transport.

## Trademarks:

PASCO, PASCO scientific, PASCO Capstone, EcoZone, ezSample, MatchGraph!, SPARKvue, SPARKlab, SPARKlink, PASPORT and Tension Protractor are trademarks or registered trademarks of PASCO scientific in the United States and/or in other countries. All other brands, products or service names are or may be trademarks or service marks of, and are used to identify products or services of, their respective owners. For more complete information visit pasco.com/legal.

## More Product Information

### Designed for education.

PASCO products are designed for education; they are not intended for use in graduate research or industry, and should not be used in any apparatus involved with life support, patient diagnosis, or industrial control.

PASCO reserves the right to change the specifications of any product without prior notice. If a product is no longer available, PASCO reserves the right to substitute a product of equal, or higher, value and functionality.

### FCC

Where appropriate, electrical products are marked to indicate that they conform to Federal Communications Commission (FCC) standards. Most commonly, FCC Part 15, Class A.

## CE MARK

Where appropriate, products carry the CE marking which indicates that they conform to the applicable European standards. This almost exclusively applies to products that are designed to meet the following applicable directives:

2004/108/EC	for electromagnetic compatibility (EMC)
2006/95/EC	for low voltage electrical equipment

## Other Regulations May Apply

Local, national, and international regulations may restrict the purchase, storage, transport, use or disposal of certain products such as chemicals, radioactive sources, and specialty products and wireless transmission devices. Please consult your local regulations to ensure compliance.

## Unless Otherwise Specified:

- Operating Temperature Range:  
0°C – 40°C (32°F to 104°F).
- Maximum Altitude (Operational): 10,000 feet
- Recommended Storage Temperature:  
10°C to 27°C (50°F to 80°F)

## Quality

PASCO Scientific meets the highest quality standards, and our quality management system is registered to ISO 9001.

## PASCO and the Environment

PASCO is committed to be in compliance with all laws and requirements in the countries in which our products are sold. PASCO is a responsible steward of the environment and as such, continually seeks to minimize the impact that our manufacturing, distribution, and consumption practices make on the planet's natural resources.

## Miscellaneous



The European Union (EU) WEEE (Waste Electrical and Electronic Equipment) symbol (left) and on the product or on its packaging indicates that this product must not be disposed of in a standard waste container.

## RoHS

All applicable products supplied by PASCO Scientific to the EU meet the requirements as specified in the RoHS directive either by substance limits or by product exemptions.



The battery or batteries used in PASCO products are marked with the European Union symbol for waste batteries (left) to indicate the need for separate collection and recycling.

# PASCO

Since 1964

The Global Leader in 21<sup>st</sup> Century Science Education

Supporting educators in over 100 countries around the world

When you have questions or need service, you want someone who understands your local needs. We carefully select, train, and support local Science Education Partners to serve our customers in each country.

When you work with a PASCO Science Education Partner, have confidence that the entire company here in California is ready to assist our Partner, and you, our Customer.

*Designed in California.  
Guaranteed by PASCO.  
Supported locally.  
Serving science educators.*



+1 916-462-8383

## ISO 9001 Certified



# A whole team behind you

*Serving educators isn't just what we do, it's who we are.*

If you have PASCO products in your classroom or lab, we want you to know that we are always here if you have questions, challenges, or need direction.

Need help getting started? Our education consultants are the best first point of contact and in a position to understand your needs.

Our customer support team can also answer any questions about products or orders.



And our Teacher Support Staff is always ready with answers to your questions or to walk you through any issues. They have a vast knowledge of all PASCO products and can mirror your exact setup to help find solutions.

In short, just tell us what you need and we will do everything we can to help.



And we stand behind the products we make with our 5 year warranty.



Once our solutions are in your hands, we want you to have the training to use them as effectively as possible.

We have an extensive library of free help videos, offer regular free online trainings, and host hands-on workshops. If you like, we can do personalized trainings at your school or university, or your instructors can come and train at PASCO.



From the production line to our shipping department, from our marketing team to our engineering groups, we are a company full of former science teachers, education experts, and professionals committed to making a difference in science education today and tomorrow. We succeed by helping you succeed.

**Phone:**

916.462.8383 (outside US)

877.373.0300 (inside US)

Fax: 916.786.7565

**Live Contact Hours:**

M–Th: 7:00 am–4:30 pm Pacific Time

F: 7:00 am–2:00 pm Pacific Time

email: [support@pasco.com](mailto:support@pasco.com)

# The PASCO Support Team: Dedicated to Science Education

Make informed decisions on what equipment best meets your needs! PASCO has fully trained Science Education Partners all around the world who are ready to work with you on equipping your lab in the most cost-effective manner. If you would like an introduction to the Science Education Partner in your country, please contact the sales director below for more information.



**Chris Wilhelm**  
Sales Director  
Western Europe  
wilhelm@pasco.com  
+1 916.462.8259



**Mark Kotlyar**  
Sales Director  
Eastern Europe & Central Asia  
mkotlyar@pasco.com  
+1 916.462.8265

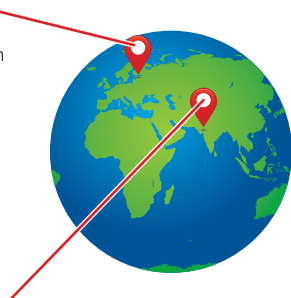

**Tom Rush**  
Sales Director  
Middle East & Africa  
trush@pasco.com  
+1 916.462.8214



**Laurie Chiu-Mar**  
Sales Director  
Asia Pacific  
chiumar@pasco.com  
+1 916.462.8224



**Humberto Medina**  
Sales Director  
Latin America & Canada  
medina@pasco.com  
+1 916.462.8223



**John Wayne**  
Senior Director  
International Sales  
wayne@pasco.com  
+1 916.462.8212

## PASCO Mission

*Providing educators worldwide with innovative solutions for teaching science*

## Teacher and Technical Support

### Melissa Pytlak

BS in Biology from State University of New York Geneseo and an MS in Plant Biology from University of California Davis



### Scott Sukrapanna

BS in Physics and an MS in Plant Biology from University of California Davis



### Mike Paskowitz

BS in Mechanical Engineering and Materials Science and an MS in Chemical Engineering and Materials Science from UC Davis



### Matthew Bannerman

BS in Zoology, MAT in Science Education, and M.Ed in Education Administration from Iowa State University



### Phone:

+1 916.462.8384

### Fax:

+1 916.786.8905

### E-mail:

intl@pasco.com  
support@pasco.com

### Mail:

**PASCO scientific**  
10101 Foothills Blvd.  
Roseville, CA 95747-7100 USA

### Web Site:

Order and quote online **pasco.com**

### Business Hours:

Monday - Thursday: 7:00 a.m. - 4:30 p.m.  
Friday: 7:00 a.m. - 2:00 p.m. Pacific Time

# PASCO

10101 Foothills Blvd. • Roseville, CA 95747-7100  
+1 916-462-8383 [www.pasco.com](http://www.pasco.com)



## Make the Switch — Modular Circuits Kits!

page 208



CTIPHY